



## FCC Information and Copyright

This equipment has been tested and found to comply with the limits of a Class B digital device, pursuant to Part 15 of the FCC Rules. These limits are designed to provide reasonable protection against harmful interference in a residential installation. This equipment generates, uses, and can radiate radio frequency energy and, if not installed and used in accordance with the instructions, may cause harmful interference to radio communications. There is no guarantee that interference will not occur in a particular installation.

The vendor makes no representations or warranties with respect to the contents here and specially disclaims any implied warranties of merchantability or fitness for any purpose. Further the vendor reserves the right to revise this publication and to make changes to the contents here without obligation to notify any party beforehand.

Duplication of this publication, in part or in whole, is not allowed without first obtaining the vendor's approval in writing.

The content of this user's manual is subject to be changed without notice and we will not be responsible for any mistakes found in this user's manual. All the brand and product names are trademarks of their respective companies.



Dichiarazione di conformità sintetica  
Ai sensi dell'art. 2 comma 3 del D.M. 275 del  
30/10/2002

Si dichiara che questo prodotto è conforme  
alle normative vigenti e soddisfa i requisiti  
essenziali richiesti dalle direttive  
2004/108/CE, 2006/95/CE e 1999/05/CE  
quando ad esso applicabili

Short Declaration of conformity

We declare this product is complying with the  
laws in force and meeting all the essential  
requirements as specified by the directives  
2004/108/CE, 2006/95/CE and 1999/05/CE  
whenever these laws may be applied

# Table Of Contents

<b>FCC Information and Copyright .....</b>	<b>1</b>
<b>Chapter 1: Introduction.....</b>	<b>3</b>
1.1 Before You Start .....	3
1.2 Package Checklist.....	3
1.3 Specifications.....	4
1.4 Rear Panel Connectors.....	5
1.5 Motherboard Layout .....	6
<b>Chapter 2: Hardware installation.....</b>	<b>7</b>
2.1 Install Central Processing Unit (CPU) .....	7
2.2 Install a Heatsink.....	8
2.3 Connect Cooling Fans .....	10
2.4 Install System Memory .....	10
2.5 Expansion Slots.....	12
2.6 Jumper & Switch Setting.....	13
2.7 Headers & Connectors.....	14
<b>Chapter 3: UEFI BIOS &amp; Software.....</b>	<b>18</b>
3.1 UEFI BIOS Setup.....	18
3.2 BIOS Update.....	18
3.3 Software.....	22
<b>Chapter 4: Useful help.....</b>	<b>25</b>
4.1 Driver Installation .....	25
4.2 AMI BIOS Beep Code.....	26
4.3 Troubleshooting.....	26
4.4 RAID Functions.....	27
<b>APPENDIX I: Specifications in Other Languages .....</b>	<b>29</b>
Arabic.....	29
German.....	30
Russian.....	31
Spanish .....	32
Thai.....	33

# Chapter 1: Introduction

## 1.1 Before You Start

Thank you for choosing our product. Before you start installing the motherboard, please make sure you follow the instructions below:

- Prepare a dry and stable working environment with sufficient lighting.
- Always disconnect the computer from power outlet before operation.
- Before you take the motherboard out from anti-static bag, ground yourself properly by touching any safely grounded appliance, or use grounded wrist strap to remove the static charge.
- Avoid touching the components on motherboard or the rear side of the board unless necessary. Hold the board on the edge, do not try to bend or flex the board.
- Do not leave any unfastened small parts inside the case after installation. Loose parts will cause short circuits which may damage the equipment.
- Keep the computer from dangerous area, such as heat source, humid air and water.
- The operating temperatures of the computer should be 0 to 45 degrees Celsius.
- To avoid injury, be careful of:
  - Sharp pins on headers and connectors
  - Rough edges and sharp corners on the chassis
  - Damage to wires that could cause a short circuit

## 1.2 Package Checklist

- Serial ATA Cable x2
- Rear I/O Panel for ATX Case x1
- User's Manual x1
- Fully Setup Driver DVD x1

---

**Note**

- » *The package contents may be different due to the sales region or models in which it was sold. For more information about the standard package in your region, please contact your dealer or sales representative.*
-

## 1.3 Specifications

Specifications	
CPU Support	Socket AM4 supports AMD A-series APU / CPU Maximum CPU TDP (Thermal Design Power): 95Watt * Please refer to <a href="http://www.biostar.com.tw">www.biostar.com.tw</a> for CPU support list.
Chipset	AMD B350 (TB350-BTC) AMD A320 (TA320-BTC)
Memory	Supports Dual Channel DDR4 1866/2133/2400/2667 2 x DDR4 DIMM Memory Slot, Max. Supports up to 32 GB Memory Each DIMM supports non-ECC & ECC 4/8/16 GB DDR4 module * DDR4 - 2667 only for Ryzen CPU. * Please refer to <a href="http://www.biostar.com.tw">www.biostar.com.tw</a> for Memory support list.
Storage	4x SATA III Connector (6Gb/s) : Supports AHCI & RAID 0, 1, 10
LAN	Realtek RTL 8111H 10/ 100/ 1000 Mb/s auto negotiation, Half / Full duplex capability
Audio Codec	ALC887 7.1 Channels, High Definition Audio
USB	6x USB 3.1 Gen1 (5Gb/s) port (4 on rear I/Os and 2 via internal headers) 6x USB 2.0 port (2 on rear I/Os and 4 via internal headers)
Expansion Slots	3x PCIe 2.0 x1 Slot 2x PCIe 3.0 x1 Slot (for Bitcoin mining, please change the speed to PCI-E 1.0 in BIOS setting) 1x PCIe 3.0 x16 Slot : When using APU or NPU, the bandwidth is x8 speed
Rear I/Os	1x PS/2 Mouse 1x PS/2 Keyboard 1x DVI-D Port 1x LAN port 4x USB 3.1 Gen1 (5Gb/s) Port 2x USB 2.0 Port (only 5V power) 2x USB 2.0 Port 3x Audio Jack
Internal I/Os	4x SATA III 6.0Gb/s Connector 2x USB 2.0 Header (each header supports 2 USB 2.0 ports) 1x USB 3.1 Gen1 (5Gb/s) Header (each header supports 2 USB 3.1 Gen1 ports) 1x 8-Pin Power Connector 1x 24-Pin Power Connector 2x 4-Pin Power Connector (for Bitcoin mining, 4pin power connector Must be installed) 1x 15-Pin SATA Power Connector (for USB power enhancement) 1x CPU Fan Connector 1x System Fan Connector 1x Front Panel Header 1x Front Audio Header 1x COM Serial Header 1x Clear CMOS Header
Form Factor	ATX Form Factor, 295 mm x 210 mm
OS Support	Windows 7(64bit) / 10(64bit) Biostar reserves the right to add or remove support for any OS with or without notice.

## 1.4 Rear Panel Connectors

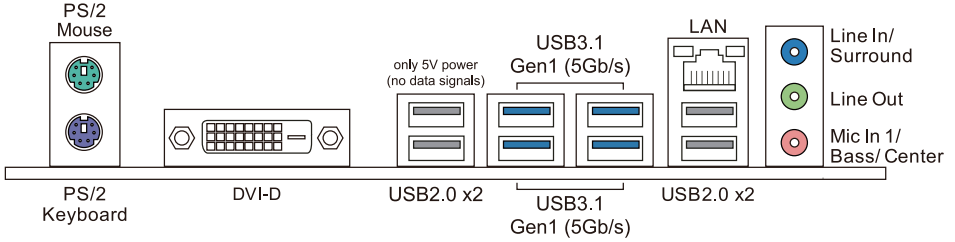

### Note

- » DVI-D output require an AMD family processor with integrated graphics.
- » Since the audio chip supports High Definition Audio Specification, the function of each audio jack can be defined by software. The input / output function of each audio jack listed above represents the default setting. However, when connecting external microphone to the audio port, please use the Line In (Blue) and Mic In (Pink) audio jack.
- » Maximum resolution  
DVI-D: 1920 x 1200 @60Hz
- » When using the front HD audio jack and plug in the headset / microphone , the rear sound will be automatically Disabled.

# 1.5 Motherboard Layout

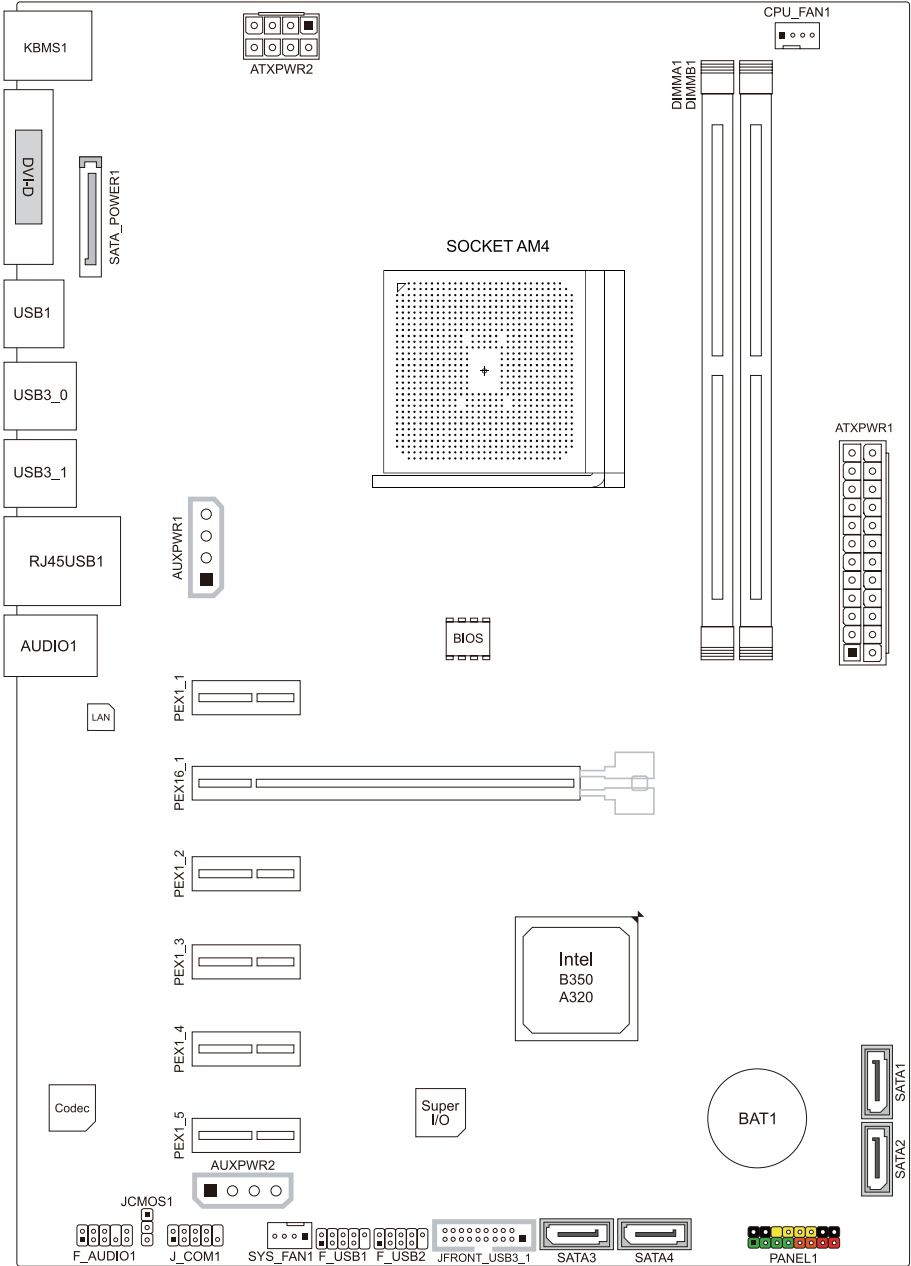

**Note**

» ■ represents the 1st pin.

## Chapter 2: Hardware installation

### 2.1 Install Central Processing Unit (CPU)

Step 1: Locate the CPU socket on the motherboard

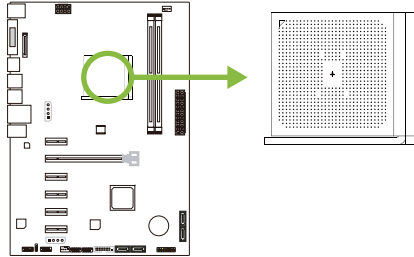

Step 2: Pull the socket locking out from the socket and then raise the lever up to a 90-degree angle.

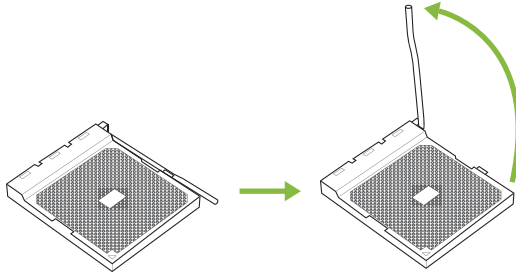

Step 3: Look for the white triangle on socket, and the gold triangle on CPU should point towards this white triangle. The CPU will fit only in the correct orientation.

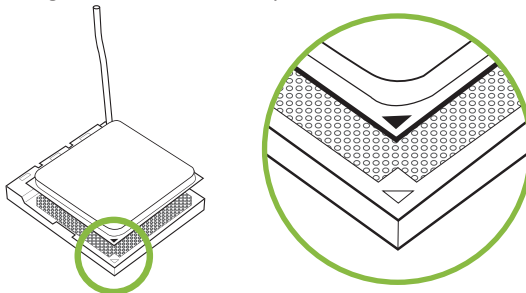

Step 4: Hold the CPU down firmly, and then close the lever to locked the position

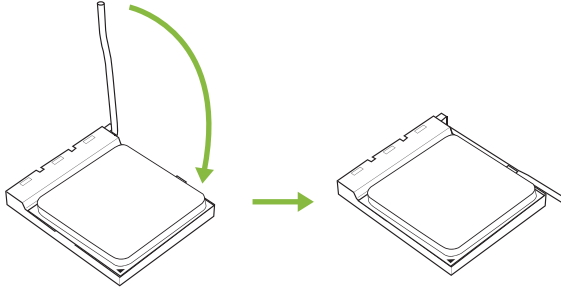

**Note**

» Please turn off the Power Supply before remove the CPU socket.

## 2.2 Install a Heatsink

### <TypeA>

Step 1: Place the heatsink and fan assembly onto the retention frame. Match the heatsink clip with the socket mounting-lug. Hook the spring clip to the mounting-lug.

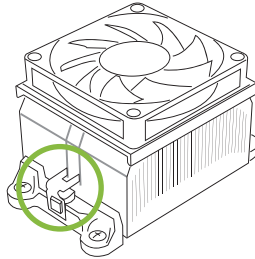

Step 2: On the other side, push the retention clip straight down to lock into the plastic lug on the retention frame, and then press down the locker until it stops.

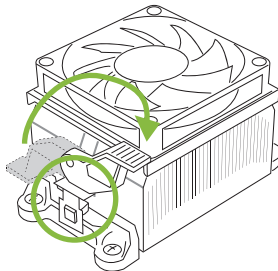



## <TypeB>

Step 1: Remove the heatsink and fan assembly bracket on the motherboard and keep the cooler backplane under the motherboard.

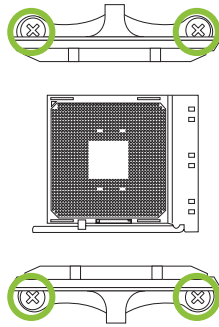

Step 2: Place the heatsink and fan assembly on top of the installed CPU and make sure that the fan cable is closest to the CPU fan connector. Please refer diagram to the following screw into the screw hole in the order shown.

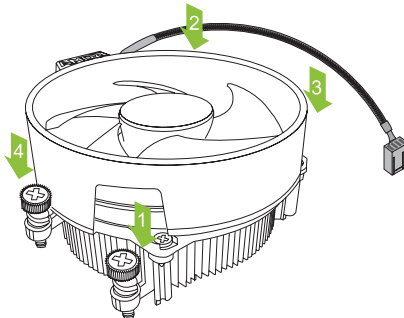

### Note

- » Do not forget to connect the CPU fan connector.
- » For proper installation, please kindly refer to the installation manual of your CPU heatsink.

## 2.3 Connect Cooling Fans

These fan headers support cooling-fans built in the computer. The fan cable and connector may be different according to the fan manufacturer.

### CPU\_FAN1: CPU Fan Header

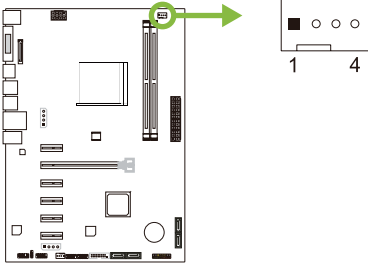

Pin	Assignment
1	Ground
2	+12V
3	FAN RPM rate sense
4	Smart Fan Control (By Fan)

### SYS\_FAN1: System Fan Header

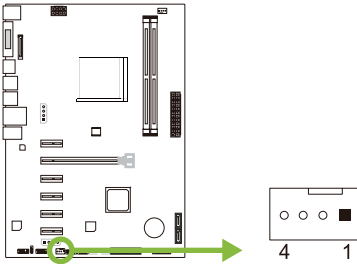

Pin	Assignment
1	Ground
2	+12V
3	FAN RPM rate sense
4	Smart Fan Control (By Fan)

#### Note

- » CPU\_FAN1, SYS\_FAN1 support 4-pin and 3-pin head connectors. When connecting with wires onto connectors, please note that the red wire is the positive and should be connected to pin#2, and the black wire is Ground and should be connected to pin#1(GND).

## 2.4 Install System Memory

### DDR4 Modules

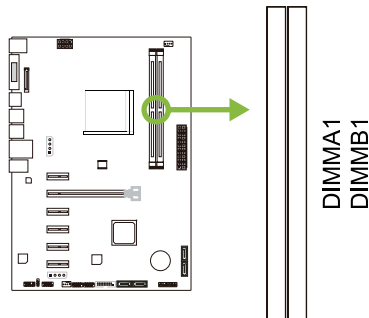

Step 1: Unlock a DIMM slot by pressing the retaining clips outward. Align a DIMM on the slot such that the notch on the DIMM matches the break on the slot.

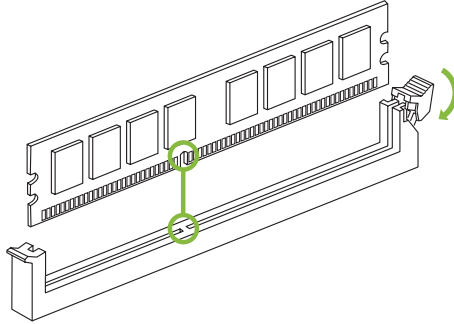

Step 2: Insert the DIMM vertically and firmly into the slot until the retaining clips snap back in place and the DIMM is properly seated.

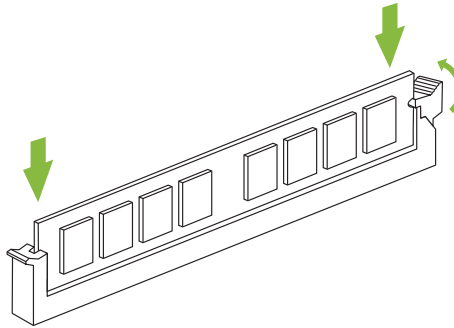

#### Note

» If the DIMM does not go in smoothly, do not force it. Pull it all the way out and try again.

## Memory Capacity

DIMM Socket Location	DDR4 Module	Total Memory Size
DIMMA1	4GB/8GB/16GB	Max is 32GB.
DIMMB1	4GB/8GB/16GB	

## Dual Channel Memory Installation

Please refer to the following requirements to activate Dual Channel function:  
Install memory module of the same density in pairs, shown in the table.

Dual Channel Status	DIMMA1	DIMMB1
Disabled	O	X
Disabled	X	O
Enabled	O	O

(O means memory installed, X means memory not installed.)

#### Note

» When installing more than one memory module, we recommend to use the same brand and capacity memory on this motherboard.

## Ryzen - DDR Maximum Frequency Support Table

Maximum	DIMMA1	DIMMB1
DDR4-2667	SR	--
DDR4-2667	DR	--
DDR4-2667	SR	SR
DDR4-2400	DR	DR

### Note

- » SR - Single-rank DIMM, 1R x4 or 1R x8.
- » DR - Dual-rank DIMMs, 2R x4 or 2R x8.
- » For the better DDR4 module compatibility, please follow the table to install your DDR4 modules.

## 2.5 Expansion Slots

### PEX16\_1: PCI-Express Gen3 x16 Slot (APU / NPU @x8 speed, Ryzen @x16 speed)

- PCI-Express 3.0 compliant.
- Theoretical maximum bandwidth using two slots simultaneously is 16GB/s for each slot, a total of 32GB/s.

### PEX1\_1/1\_2: PCI-Express Gen3 x1 Slot

- PCI-Express 3.0 compliant.
- Data transfer bandwidth up to 1GB/s per direction; 2GB/s in total.

### PEX1\_3/1\_4/1\_5: PCI-Express Gen2 x1 Slot

- PCI-Express 2.0 compliant.
- Data transfer bandwidth up to 500MB/s per direction; 1GB/s in total.

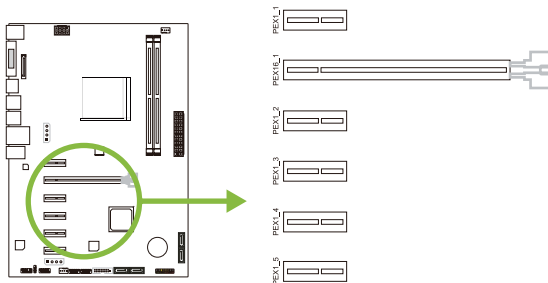

## Install an Expansion Card

You can install your expansion card by following steps:

- Read the related expansion card's instruction document before install the expansion card into the computer.
- Remove your computer's chassis cover, screws and slot bracket from the computer.
- Place a card in the expansion slot and press down on the card until it is completely seated in the slot.
- Secure the card's metal bracket to the chassis back panel with a screw.
- Replace your computer's chassis cover.
- Power on the computer, if necessary, change BIOS settings for the expansion card.
- Install related driver for the expansion card.

## 2.6 Jumper & Switch Setting

The illustration shows how to set up jumpers. When the jumper cap is placed on pins, the jumper is “close”, if not, that means the jumper is “open”.

Pin opened



Pin closed



Pin 1-2 closed



### JCMOS1: Clear CMOS Jumper

The jumper allows users to restore the BIOS safe setting and the CMOS data. Please carefully follow the procedures to avoid damaging the motherboard.

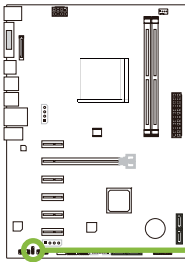

Pin 1-2 Close:

Normal Operation (default).



Pin 2-3 Close:

Clear CMOS data.

#### Clear CMOS Procedures:

1. Remove AC power line.
2. Set the jumper to “Pin 2-3 close”.
3. Wait for five seconds.
4. Set the jumper to “Pin 1-2 close”.
5. Power on the AC.
6. Load Optimal Defaults and save settings in CMOS.

## 2.7 Headers & Connectors

### ATXPWR1: ATX Power Source Connector

For better compatibility, we recommend to use a standard ATX 24-pin power supply for this connector. Make sure to find the correct orientation before plugging the connector.

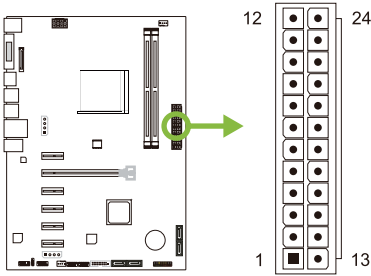

Pin	Assignment	Pin	Assignment
13	+3.3V	1	+3.3V
14	-12V	2	+3.3V
15	Ground	3	Ground
16	PS_ON	4	+5V
17	Ground	5	Ground
18	Ground	6	+5V
19	Ground	7	Ground
20	NC	8	PW_OK
21	+5V	9	Standby Voltage+5V
22	+5V	10	+12V
23	+5V	11	+12V
24	Ground	12	+3.3V

### ATXPWR2: ATX Power Source Connector

The connector provides +12V to the CPU power circuit. If the CPU power plug is 4-pin, please plug it into Pin 1-2-5-6 of ATXPWR2.

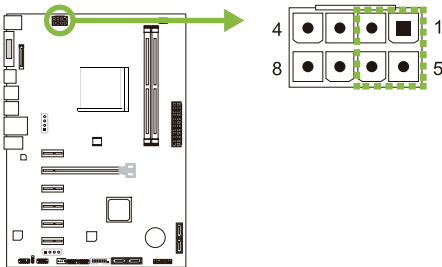

Pin	Assignment
1	+12V
2	+12V
3	+12V
4	+12V
5	Ground
6	Ground
7	Ground
8	Ground

#### Note

- » Before you power on the system, please make sure that both ATXPWR1 and ATXPWR2 connectors have been plugged-in.
- » Insufficient power supplied to the system may result in instability or the peripherals not functioning properly. Use of a PSU with a higher power output is recommended when configuring a system with more power-consuming devices.

## AUXPWR1/2: Auxiliary Power for Graphics

(for Bitcoin mining, 4pin power connector must be installed)

This connector is an auxiliary power connection for graphics cards. Exclusive power for the graphics card provides better graphics performance.

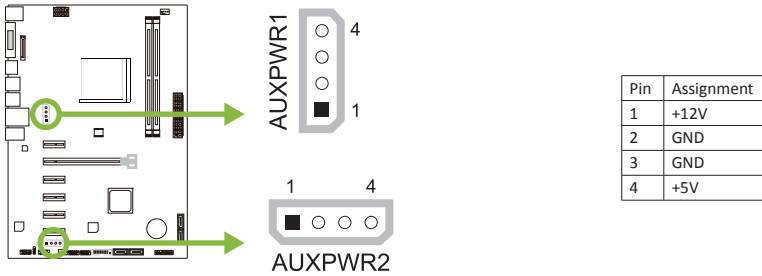

## SATA\_POWER1: SATA Power Connector

This SATA power connector enhances the power of rear USB ports.

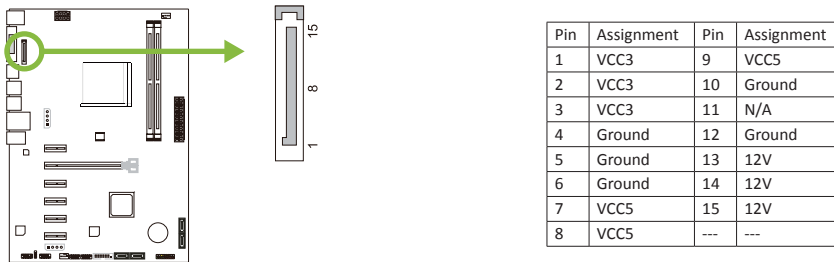

## PANEL1: Front Panel Header

This 16-pin header includes Power-on, Reset, HDD LED, Power LED, and speaker connection.

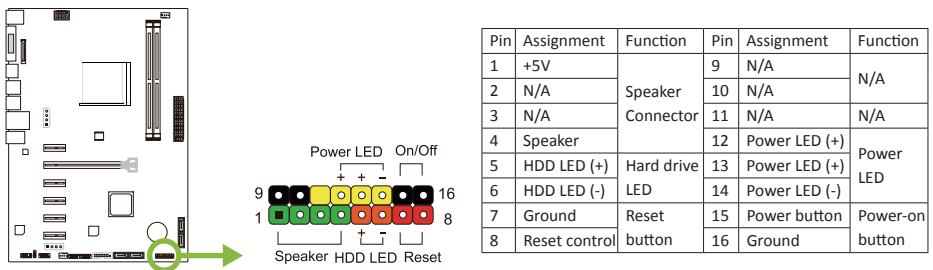

### SATA1~SATA4: Serial ATA 6.0 Gb/s Connectors

These connectors connect to SATA hard disk drives via SATA cables.

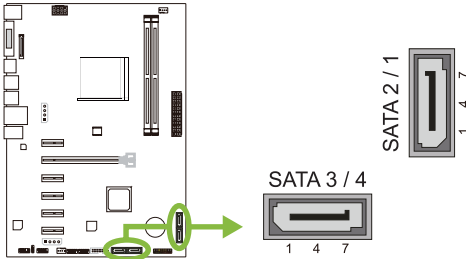

Pin	Assignment
1	Ground
2	TX+
3	TX-
4	Ground
5	RX-
6	RX+
7	Ground

### JFRONT\_USB3\_1: Header for USB 3.1 Gen1 (5Gb/s) Ports at Front Panel

This header allows user to add additional USB ports on the PC front panel, and also can be connected with a wide range of external peripherals.

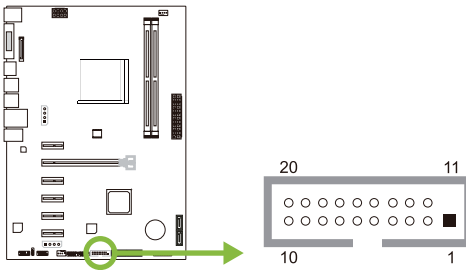

Pin	Assignment	Pin	Assignment
1	VBUS0	11	D2+
2	SSRX1-	12	D2-
3	SSRX1+	13	Ground
4	Ground	14	SSTX2+
5	SSTX1-	15	SSTX2-
6	SSTX1+	16	Ground
7	Ground	17	SSRX2+
8	D1-	18	SSRX2-
9	D1+	19	VBUS1
10	ID	20	Key

### F\_USB1/2: Header for USB 2.0 Ports at Front Panel

This header allows user to add additional USB ports on the PC front panel, and also can be connected with a wide range of external peripherals.

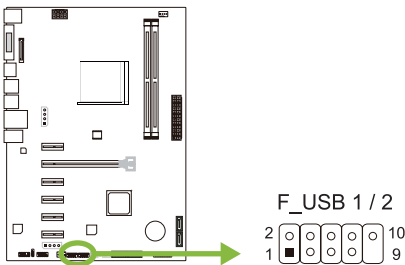

Pin	Assignment
1	+5V (fused)
2	+5V (fused)
3	USB-
4	USB-
5	USB+
6	USB+
7	Ground
8	Ground
9	Key
10	NC



## F\_AUDIO1: Front Panel Audio Header

This header allows user to connect the chassis-mount front panel audio I/O which supports HD and AC'97 audio standards.

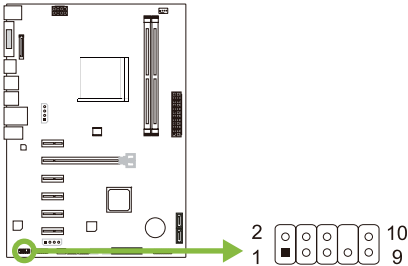

HD Audio		AC'97	
Pin	Assignment	Pin	Assignment
1	Mic Left in	1	Mic In
2	Ground	2	Ground
3	Mic Right in	3	Mic Power
4	GPIO	4	Audio Power
5	Right line in	5	RT Line Out
6	Jack Sense	6	RT Line Out
7	Front Sense	7	Reserved
8	Key	8	Key
9	Left line in	9	LFT Line Out
10	Jack Sense	10	LFT Line Out

### Note

- » It is recommended that you connect a high-definition front panel audio module to this connector to avail of the motherboard's high definition audio capability.
- » Please try to disable the "Front Panel Jack Detection" if you want to use an AC'97 front audio output cable. The function can be found via O.S. Audio Utility.

## J\_COM1: Serial Port Connector

The motherboard has a serial port header for connecting RS-232 Port.

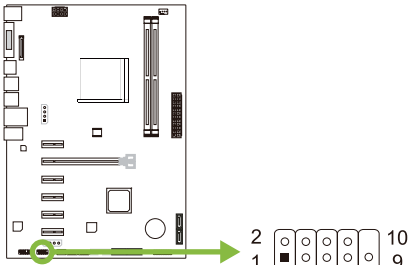

Pin	Assignment
1	Carrier detect
2	Received data
3	Transmitted data
4	Data terminal ready
5	Signal ground
6	Data set ready
7	Request to send
8	Clear to send
9	Ring indicator
10	Key

## Chapter 3: UEFI BIOS & Software

### 3.1 UEFI BIOS Setup

- The BIOS Setup program can be used to view and change the BIOS settings for the computer. The BIOS Setup program is accessed by pressing the <DEL> key after the Power-On Self-Test (POST) memory test begins and before the operating system boot begins.
- For further information of setting up the UEFI BIOS, please refer to the UEFI BIOS Manual on our website.

### 3.2 BIOS Update

The BIOS can be updated using either of the following utilities:

- **BIOSTAR BIOS Flasher:** Using this utility, the BIOS can be updated from a file on a hard disk, a USB drive (a flash drive or a USB hard drive), or a CD-ROM.
- **BIOSTAR BIOS Update Utility:** It enables automated updating while in the Windows environment. Using this utility, the BIOS can be updated from a file on a hard disk, a USB drive (a flash drive or a USB hard drive), or a CD-ROM, or from the file location on the Web.

#### **BIOSTAR BIOS Flasher**

##### **Note**

- » This utility only allows storage device with FAT32/16 format and single partition.
- » Shutting down or resetting the system while updating the BIOS will lead to system boot failure.

Updating BIOS with BIOSTAR BIOS Flasher

1. Go to the website to download the latest BIOS file for the motherboard.
2. Then, copy and save the BIOS file into a USB flash (pen) drive. (Only supported FAT/FAT32 format)
3. Insert the USB pen drive that contains the BIOS file to the USB port.
4. Power on or reset the computer and then press <F12> during the POST process.

5. After entering the POST screen, the BIOS-FLASHER utility pops out. Choose <fs0> to search for the BIOS file.



6. Select the proper BIOS file, and a message asking if you are sure to flash the BIOS file. Click “Yes” to start updating BIOS.

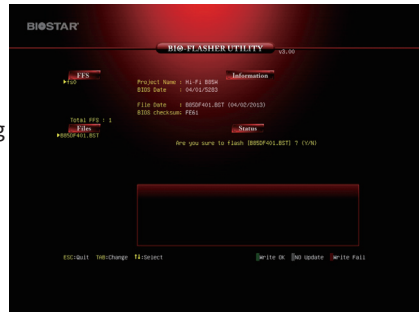

7. A dialog pops out after BIOS flash is completed, asking you to restart the system. Press the <Y> key to restart system.

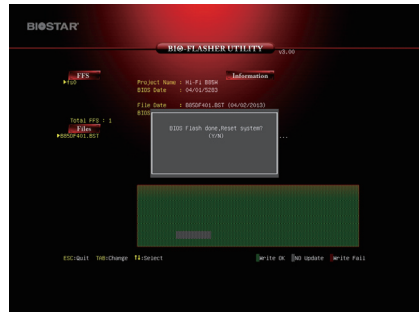

8. While the system boots up and the full screen logo shows up, press <DEL> key to enter BIOS setup.

After entering the BIOS setup, please go to the <Save & Exit>, using the <Restore Defaults> function to load Optimized Defaults, and select <Save Changes and Reset> to restart the computer. Then the BIOS Update is completed.

### **BIOS Update Utility (through the Internet)**

1. Installing BIOS Update Utility from the DVD Driver.
2. Please make sure the system is connected to the internet before using this function.

3. Launch BIOS Update Utility and click the “Online Update” button on the main screen.



4. An open dialog will show up to request your agreement to start the BIOS update. Click “Yes” to start the online update procedure.

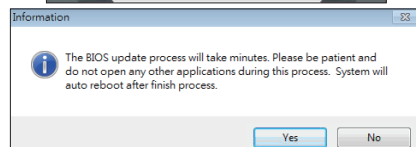

5. If there is a new BIOS version, the utility will ask you to download it. Click “Yes” to proceed.

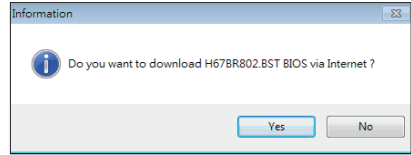

6. After the download is completed, you will be asked to program (update) the BIOS or not. Click “Yes” to proceed.

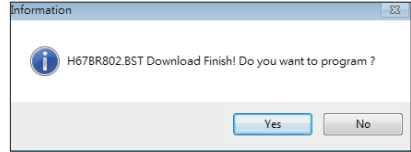

7. After the updating process is finished, you will be asked you to reboot the system. Click “OK” to reboot.

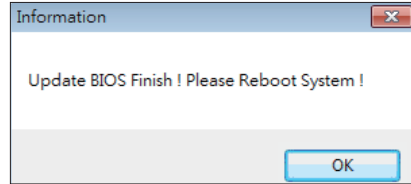

8. While the system boots up and the full screen logo shows up, press <DEL> key to enter BIOS setup.

After entering the BIOS setup, please go to the <Save & Exit>, using the <Restore Defaults> function to load Optimized Defaults, and select <Save Changes> and <Reset> to restart the computer. Then, the BIOS Update is completed.

### **BIOS Update Utility (through a BIOS file)**

1. Installing BIOS Update Utility from the DVD Driver.
2. Download the proper BIOS from <http://www.biostar.com.tw/>

3. Launch BIOS Update Utility and click the “Update BIOS” button on the main screen.



4. A warning message will show up to request your agreement to start the BIOS update. Click “OK” to start the update procedure.

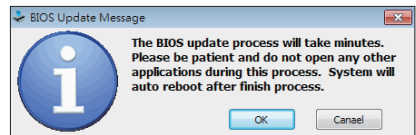

5. Choose the location for your BIOS file in the system. Please select the proper BIOS file, and then click on "Open". It will take several minutes, please be patient.

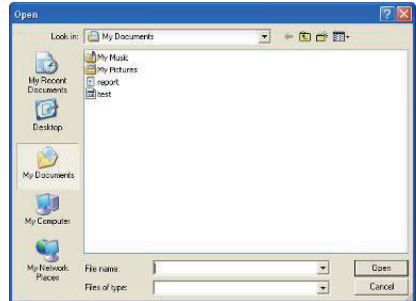

6. After the BIOS Update process is finished, click on "OK" to reboot the system.

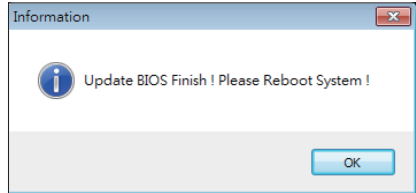

7. While the system boots up and the full screen logo shows up, press <DEL> key to enter BIOS setup. After entering the BIOS setup, please go to the <Save & Exit>, using the <Restore Defaults> function to load Optimized Defaults, and select <Save Changes and Reset> to restart the computer. Then, the BIOS Update is completed.

### **Backup BIOS**

Click the Backup BIOS button on the main screen for the backup of BIOS, and select a proper location for your backup BIOS file in the system, and click "Save".

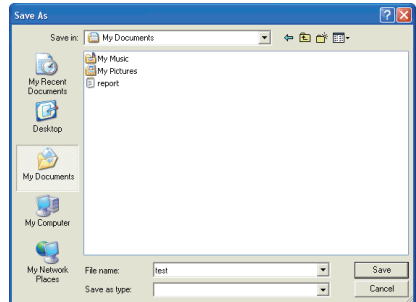

### 3.3 Software

#### Installing Software

1. Insert the Setup DVD to the optical drive. The driver installation program would appear if the Auto-run function has been enabled.
2. Select Software Installation, and then click on the respective software title.
3. Follow the on-screen instructions to complete the installation.

#### Launching Software

After the installation process is completed, you will see the software icon showing on the desktop. Double-click the icon to launch it.

#### Note

- » All the information and content about following software are subject to be changed without notice. For better performance, the software is being continuously updated.
- » The information and pictures described below are for your reference only. The actual information and settings on board may be slightly different from this manual.

#### BIOScreen Utility

This utility allows you to personalize your boot logo easily. You can choose BMP as your boot logo so as to customize your computer.



Please follow the step-by-step instructions below to update boot logo:

- Load Image: Choose the picture as the boot logo.
- Transform: Transform the picture for BIOS and preview the result.
- Update Bios: Write the picture to BIOS Memory to complete the update.

## eHot-Line

eHot-Line is a convenient utility that helps you to contact with our Tech-Support system. This utility will collect the system information which is useful for analyzing the problem you may have encountered, and then send these information to our tech-support department to help you fix the problem.

\* represents important information that you must provide. Without this information, you may not be able to send out the mail.

This block will show the information which would be collected in the mail.

\* Describe condition of your system.

\* Select your area or the area close to you.

Provide the e-mail address that you would like to send the copy to.

\* Provide the name of the memory module manufacturer.

Provide the name of the power supply manufacturer and the model no.

Send the mail out.

Exit this dialog.

Save these information to a .txt file

```

eHot-Line
-----
Base board information :
Caption : Base Board
CreationClassName : Win32_Base
Description : Base Board
HostingBoard : TRUE
HotSwappable : FALSE
Manufacturer : BIOSTAR Group
Name : Base Board
PoweredOn : TRUE
Product : TA780C M2+
Removable : FALSE
Replaceable : TRUE
RequiresDaughterBoard : FALSE
SerialNumber : None
Status : OK
Tag : Base Board
Version : 6.0
  
```

Symptom Description :

Region :

CC E-mail :

Memory Module Manufacture :

Power Supply Manufacture/model :

Send Save As... Exit

After filling up this information, click “Send” to send the mail out. A warning dialog would appear asking for your confirmation; click “Send” to confirm or “Do Not Send” to cancel.

If you want to save this information to a .txt file, click “Save As...” and then you will see a saving dialog appears asking you to enter file name.

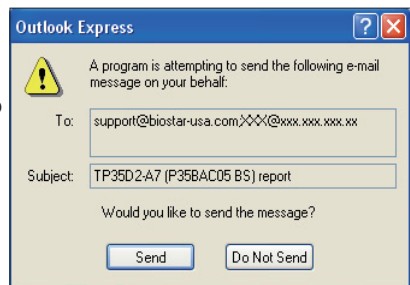

Enter the file name and then click “Save”. Your system information will be saved to a .txt file.

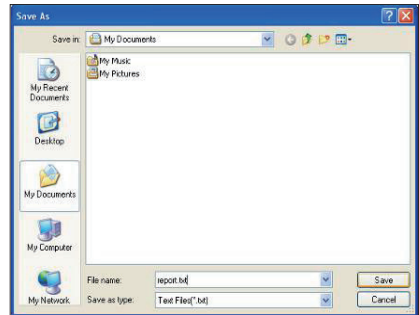

Open the saved .txt file, you will see your system information including motherboard/BIOS/CPU/video/device/OS information. This information is also concluded in the sent mail.

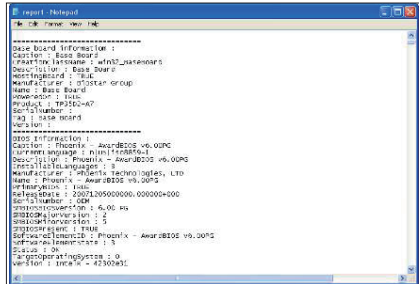

**Note**

- » Before you use this utility, please set Outlook Express as your default e-mail client application program.
- » We will not share customer's data with any other third parties, so please feel free to provide your system information while using eHot-Line service.
- » If you are not using Outlook Express as your default e-mail client application, you may need to save the system information to a .txt file and send the file to our tech support with other e-mail application. Go to the following website <http://www.biostar.com.tw/app/en/about/contact.php> for getting our contact information.



## Chapter 4: Useful Help

### 4.1 Driver Installation

After you installed your operating system, please insert the Fully Setup Driver DVD into your optical drive and install the driver for better system performance.

You will see the following window after you insert the DVD



The setup guide will auto detect your motherboard and operating system.

#### **A. Driver Installation**

To install the driver, please click on the Driver icon. The setup guide will list the compatible driver for your motherboard and operating system. Click on each device driver to launch the installation program.

#### **B. Software Installation**

To install the software, please click on the Software icon. The setup guide will list the software available for your system, click on each software title to launch the installation program.

#### **C. Manual**

Aside from the paperback manual, we also provide manual in the Driver DVD. Click on the Manual icon to browse for available manual.

#### **► Note**

- » *If this window didn't show up after you insert the Driver DVD, please use file browser to locate and execute the file SETUP.EXE under your optical drive.*
- » *You will need Acrobat Reader to open the manual file. Please download the latest version of Acrobat Reader software from <http://get.adobe.com/reader/>*

## 4.2 AMI BIOS Beep Code

### Boot Block Beep Codes

Number of Beeps	Description
Continuing	Memory sizing error or Memory module not found

### POST BIOS Beep Codes

Number of Beeps	Description
1	Success booting.
8	Display memory error (system video adapter)

## 4.3 Troubleshooting

Probable	Solution
<ol style="list-style-type: none"> <li>1. There is no power in the system. Power LED does not shine; the fan of the power supply does not work.</li> <li>2. Indicator light on keyboard does not shine.</li> </ol>	<ol style="list-style-type: none"> <li>1. Make sure power cable is securely plugged in.</li> <li>2. Replace cable.</li> <li>3. Contact technical support.</li> </ol>
System is inoperative. Keyboard lights are on, power indicator lights are lit, and hard drives are running.	Using even pressure on both ends of the DIMM, press down firmly until the module snaps into place.
System does not boot from a hard disk drive, but can be booted from optical drive.	<ol style="list-style-type: none"> <li>1. Check cable running from disk to disk controller board. Make sure both ends are securely plugged in; check the drive type in the standard CMOS setup.</li> <li>2. Backing up the hard drive is extremely important. All hard disks are capable of breaking down at any time.</li> </ol>
System only boots from an optical drive. Hard disks can be read, applications can be used, but system fails to boot from a hard disk.	<ol style="list-style-type: none"> <li>1. Back up data and applications files.</li> <li>2. Reformat the hard drive. Re-install applications and data using backup disks.</li> </ol>
Screen message shows "Invalid Configuration" or "CMOS Failure."	Review system's equipment. Make sure correct information is in setup.
System cannot boot after user installs a second hard drive.	<ol style="list-style-type: none"> <li>1. Set master/slave jumpers correctly.</li> <li>2. Run SETUP program and select correct drive types. Call the drive manufacturers for compatibility with other drives.</li> </ol>

### **CPU Overheated**

If the system shutdown automatically after power on system for seconds, that means the CPU protection function has been activated.

When the CPU is over heated, the motherboard will shutdown automatically to avoid a damage of the CPU, and the system may not power on again.

In this case, please double check:

1. The CPU cooler surface is placed evenly with the CPU surface.
2. CPU fan is rotated normally.
3. CPU fan speed is fulfilling with the CPU speed.

After confirmed, please follow steps below to relief the CPU protection function.

1. Remove the power cord from power supply for seconds.
2. Wait for seconds.
3. Plug in the power cord and boot up the system.

Or you can:

1. Clear the CMOS data. (See “Close CMOS Header: JCMOS1” section)
2. Wait for seconds.
3. Power on the system again.

## **4.4 RAID Functions**

### **RAID Definitions**

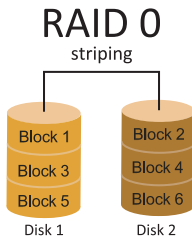

In a RAID 0 system data are split up in blocks that get written across all the drives in the array. By using multiple disks (at least 2) at the same time, this offers superior I/O performance. This performance can be enhanced further by using multiple controllers, ideally one controller per disk.

### **Features and Benefits**

- Drives: Minimum 2, and maximum is up to 6 or 8. Depending on the platform.
- Uses: Intended for non-critical data requiring high data throughput, or any environment that does not require fault tolerance.
- Benefits: provides increased data throughput, especially for large files. No capacity loss penalty for parity.
- Drawbacks: Does not deliver any fault tolerance. If any drive in the array fails, all data is lost.
- Fault Tolerance: No.
- Total Capacity: (Minimal. HDD Capacity) x (Connected HDDs Amount)

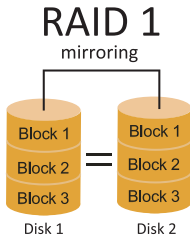

Data are stored twice by writing them to both the data disk (or set of data disks) and a mirror disk (or set of disks). If a disk fails, the controller uses either the data drive or the mirror drive for data recovery and continues operation. You need at least 2 disks for a RAID 1 array.

#### Features and Benefits

- Drives: Minimum 2, and maximum is 2.
- Uses: RAID 1 is ideal for small databases or any other application that requires fault tolerance and minimal capacity.
- Benefits: Provides 100% data redundancy. Should one drive fail, the controller switches to the other drive.
- Drawbacks: Requires 2 drives for the storage space of one drive. Performance is impaired during drive rebuilds.
- Fault Tolerance: Yes.

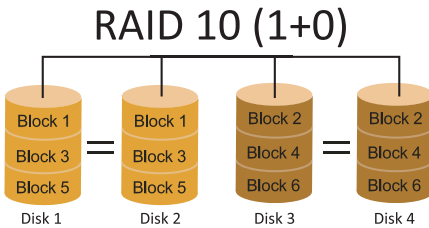

RAID 10 combines the advantages (and disadvantages) of RAID 0 and RAID 1 in one single system. It provides security by mirroring all data on a secondary set of disks (disk 3 and 4 in the drawing below) while using striping across each set of disks to speed up data transfers.

#### Features and Benefits

- Drives: Minimum 4, and maximum is 6 or 8, depending on the platform.
- Benefits: Optimizes for both fault tolerance and performance, allowing for automatic redundancy. May be simultaneously used with other RAID levels in an array, and allows for spare disks.
- Drawbacks: Requires twice the available disk space for data redundancy, the same as RAID level 1.
- Fault Tolerance: Yes.

## APPENDIX I: Specifications in Other Languages

## Arabic

المواصفات	
قاعدة وحدة المعالجة المركزية	الماخذ AM4 دعم AMD سلسلة CPU / APU الحد الأقصى للطاقة الحرارية في تصميم المعالج (TDP – thermal design power): 95 واط. * يرجى الرجوع إلى الموقع <a href="http://www.biostar.com.tw">www.biostar.com.tw</a> لقائمة دعم المعالج CPU.
مجموعة الشرائح	AMD B350 (TB350-BTC) AMD A320 (TA320-BTC)
الذاكرة	تدعم قناة مزدوجة دي. دي. ار. DDR4 / 2133 / 2400 / 2667 x2 دي. دي. ار. DDR4 فتحات الذاكرة المزدوجة DIMM، تتحمل كحد أقصى 32 جيجابايت ذاكرة كل فتحة مزدوجة DIMM تتحمل دون ECC & ECC 16/8/4 جيجابايت دي. دي. ار DDR4 * DDR4 - 2667 فقط Ryzen وحدة المعالجة المركزية. * يرجى الرجوع إلى الموقع <a href="http://www.biostar.com.tw">www.biostar.com.tw</a> لقائمة دعم الذاكرة.
التخزين	4X SATA III موصل 6 جيجا بايت: الدعم RAID & AHCI 10 / 1 / 0
شبكة محلية LAN	ريالتيك رت ل RTL 8111H, REALTEK 1000 / 100 / 10 ميجابايت / الثانية، تحديد تلقائي، النصف / القدرة القصوى المزدوجة
الترميز الصوتي	ALC887 7.1 قنوات عالية الدقة
ناقل متسلسل عام USB	منافذ 6 x ناقل متسلسل عام USB 3.1 Gen1 (5Gb/s) - (4 في المداخل والمخارج الخلفية و 2 من خلال الموزع الداخلي) منافذ 6 x ناقل متسلسل عام USB 2.0 (2 في المداخل والمخارج الخلفية و 4 من خلال الموزع الداخلي)
فتحات التوسع	x3 فتحة منفذ الملحقات الإضافية PCIe x2.0 1 x2 فتحة منفذ الملحقات الإضافية PCIe x3.0 1 (للتعدين بيتكوين، يرجى تغيير السرعة إلى 1.0 E في إعداد بيوس) x 1 فتحة منفذ الملحقات الإضافية PCIe x3.0 16: عند استخدام APU أو NPU النطاق الترددي هو سرعة x8
المداخل والمخارج الخلفية	x 1 PS/2 الفأرة x 1 PS/2 لوحة المفاتيح للكمبيوتر فتحة توصيل عدد x 1 واجهة مرئية رقمية DVI-D فتحة لتوصيل عدد x 1 الشبكة المحلية LAN فتحة توصيل عدد x 4 ناقل متسلسل عام USB 3.1 Gen1 (5Gb/s) فتحة توصيل عدد x 2 ناقل متسلسل عام USB 2.0 (فقط 5V السلطة) فتحة توصيل عدد x 2 ناقل متسلسل عام USB 2.0 فتحة توصيل عدد x 3 جاك للصوت
المداخل والمخارج الداخلية	x4 SATA III موصل 6 جيجا بايت موزع x2 ناقل متسلسل عام USB 2.0 (كل موزع يتحمل فتحتين ناقل متسلسل عام USB 2.0) موزع x1 ناقل متسلسل عام USB 3.1 Gen1 (5Gb/s) - (كل موزع يتحمل فتحتين ناقل متسلسل عام USB 3.1) موصلة للطاقة 8 x 1 دبابيس وصلة للطاقة x1 24 دبابيس وصلة للطاقة x 2 4 دبابيس (للتعدين بيتكوين، موصل الطاقة 4pin يجب تثبيت) وصلة للطاقة x 1 SATA 15 دبابيس (ل أو سب تعزيز الطاقة) وصلة x 1 مروحة تبريد وحدة المعالجة المركزية وصلة x 1 مراوح تبريد المنظومة موزع x 1 اللوحة الأمامية موزع x 1 الصوت الأمامي موزع x 1 فتحة تسلسلية موزع x 1 سيموس مباشر
عامل الشكل	عامل شكل مدد التكنولوجيا المتقدمة ATX ، 295 x 210 مم
أنظمة التشغيل المدعومة	ويندوز 7(64bit) / 10(64bit) بيوستار BIOSTAR تحتفظ بحق إضافة أو إزالة الدعم لأي نظام تشغيل مع أو بدون أنظار.

## German

Spezifikationen	
CPU-Unterstützung	Anschluss-AM4 für AMD A-Serie APU / CPU Maximale CPU TDP (Thermal Design Power): 95 Watt * Bitte konsultieren Sie <a href="http://www.biostar.com.tw">www.biostar.com.tw</a> für CPU-Unterstützungsliste
Chipset	AMD B350 (TB350-BTC) AMD A320 (TA320-BTC)
Festplattenspeicher	Unterstützt zweikanaliges DDR4 1866/2133/2400/2667 2 x DDR4 DIMM-SpeicherSlot, Max. Unterstützung bis zu 32 GB-Speicher Jedes DIMM unterstützt nicht-ECC & ECC 4/8/16 GB DDR4-Module * DDR4 - 2667 nur für Ryzen CPU. * Bitte konsultieren Sie <a href="http://www.biostar.com.tw">www.biostar.com.tw</a> für Speicherunterstützung Liste.
Arbeitsspeicher	4x SATA III 6Gb-Verbindung : Unterstützt AHCI & RAID 0,1,10
LAN	Realtek RTL 8111H 10/ 100/ 1000 Mb Auto-Negotiation, Halb- / Voll-Duplex-fähig
Audio-Codec	ALC887 7.1 Kanäle, HD-Audio
USB	6x USB 3.1 Gen1 (5Gb/s)-Port (4 hintere I/Os und 2 via interne Header) 6x USB 2.0-Port (2 hintere I/Os und 4 via interne Header)
Erweiterungsanschlüsse	3x PCIe 2.0 x1-Slot 2x PCIe 3.0 x1-Slot (Für Bitcoin Mining, ändern Sie die Geschwindigkeit auf PCI-E 1.0 in BIOS-Einstellung) 1x PCIe 3.0 x16-Slot : Bei Verwendung von APU oder NPU ist die Bandbreite x8 Geschwindigkeit
Hintere I/Os	1x PS/2-Mausd 1x PS/2-Keyboard 1x DVI-D-Port 1x LAN-Port 4x USB 3.1 Gen1 (5Gb/s)-Port 2x USB 2.0-Port (Nur 5V Energie) 2x USB 2.0-Port 3x Audio Jack
Interne I/Os	4x SATA III 6.0Gb/s-Verbinung 2x USB 2.0-Header (jeder Header unterstützt 2 USB 2.0-Ports) 1x USB 3.1 Gen1 (5Gb/s)-Header (jeder Header unterstützt 2 USB 3.1 Gen1-Ports) 1x 8-Pin-Stromverbindung 1x 24-Pin-Stromverbindung 2x 4-Pin-Stromverbindung (Für Bitcoin Mining, 4pin Stromanschluss Muss installiert sein) 1x 15-poliger SATA-Stromanschluss (Für USB-Leistungserhöhung) 1x CPU-Ventilatorverbindung 1x System-Ventilatorverbindung 1x Header für Frontpanel 1x Header für Frontaudio 1x Header für Seriellen Anschluss 1x Header für klares CMOS
Formfaktor	ATX Formfaktor, 295 mm x 210 mm
OS-Unterstützung	Windows 7(64bit) / 10(64bit) Biostar reserves the right to add or remove support for any OS with or without notice

## Russian

Спецификации	
Поддержка центрального процессора	Сокет AM4 для процессоров AMD серии A - APU / CPU Максимальный термопакет центрального процессора (TDP): 95 ватт * Перечень поддержки центрального процессора смотрите на <a href="http://www.biostar.com.tw">www.biostar.com.tw</a> .
Набор микросхем	AMD B350 (TB350-BTC) AMD A320 (TA320-BTC)
Память	Поддерживает двухканальный DDR4 1866/2133/2400/2667 2 гнезда платы памяти DDR4 DIMM, максимальная память до 32 Гб Каждый модуль DIMM поддерживает модуль не-ECC & ECC 4/8/16 Гб DDR4 * DDR4 - 2667 только для Ryzen CPU. * Перечень поддержки памяти смотрите на <a href="http://www.biostar.com.tw">www.biostar.com.tw</a> .
Накопитель	Соединитель 4x SATA III 6 Гб/с : Поддерживает AHCI & RAID 0,1,10
Локальная сеть	Realtek RTL 8111H Автосогласование 10/ 100/ 1000 Мб/с, работает в полно/полудуплексном режиме
Аудиокодек	ALC887 Каналы 7.1, высококачественное аудио
USB	6 портов USB 3.1 Gen1 (5Gb/s) - (4 сзади ввода-вывода и 2 через внутренние контакты) 6 портов USB 2.0 (2 сзади ввода-вывода и 4 через внутренние контакты)
Гнезда расшир.	3x гнезда PCIe 2.0 x1 2x гнезда PCIe 3.0 x1 (Для добычи Bitcoin, изменить скорость PCI-E 1.0 в настройки BIOS) 1x PCIe 3.0 x16 гнездо : При использовании APU или NPU, пропускная способность скорости x8
Задняя плата ввода-вывода	1 мышь PS / 2 1 клавиатура PS / 2 1 порт DVI-D 1 порт локальной сети 4 порта USB 3.1 Gen1 (5Gb/s) 2 порта USB 2.0 (только 5V питания) 2 порта USB 2.0 3 гнезд для подключения наушников
Внутр. Плата ввода-вывода	Соединитель 4x SATA III 6Гб/с 2 контакта USB 2.0 (каждый контакт поддерживает 2 порта USB 2.0) 1 контакта USB 3.1 Gen1 (5Gb/s) - (каждый контакт поддерживает 2 порта USB 3.1 Gen1) 1 8-выводный разъем питания 1 24-выводный разъем питания 2 4-выводный разъем питания (для добычи Bitcoin, 4pin разъем питания Должен быть установлен) 1 разъем SATA питания 15-контактный (для повышения мощности USB) 1 разъем вентилятора ЦП 1 разъема вентилятора системы 1 контакт передней панели 1 контакт передней аудиопанели 1 контакт последовательного порта 1 контакт микросхемы Clear CMOS
Конструктив	Форм-фактор ATX, 295 мм x 210 мм
Поддержка ОС	Windows 7(64bit) / 10(64bit) Biostar оставляет за собой право добавлять или удалять поддержку любой ОС, с уведомлением или без.

## Spanish

Especificaciones	
Compatibilidad con el procesador	Ranura AM4 Soporta AMD serie - A - APU / CPU Alimentación de Proyección Térmica (TDP – Thermal Design Power): 95Watt *Por favor consultar con <a href="http://www.biostar.com.tw">www.biostar.com.tw</a> para la lista de compatibilidad con el procesador.
Tipo de Placa	AMD B350 (TB350-BTC) AMD A320 (TA320-BTC)
Memoria	Soporta DDR4 1866/2133/2400/2667 Doble Canal 2x DDR4 DIMM Ranura de memoria Soporta hasta 32 GB Memoria Cada DIMM soporta un modulo non-ECC & ECC 4/8/16 GB DDR4 * DDR4 - 2667 sólo para CPU Ryzen. *Por favor consultar con <a href="http://www.biostar.com.tw">www.biostar.com.tw</a> para la lista de compatibilidad con el memoria.
Almacenamiento de información	Conector 4x SATA III (6Gb/s) : Soporta AHCI & RAID 0,1,10
LAN	Realtek RTL 8111H 10/ 100/ 1000 Mb/s auto negociación, capacidad dúplex Mitad/Completo
Códec Audio	ALC887 Canales Audio de Alta Definición 7.1
USB	Ranura 6x USB 3.1 Gen1 (5Gb/s) - (4 en las entradas/salidas posteriores y 2 por los distribuidores internos) Ranura 6x USB 2.0 (2 en las entradas/salidas posteriores y 4 por los distribuidores internos)
Ranuras de Extinción	Ranura 3x PCIe 2.0 x1 Ranura 2x PCIe 3.0 x1 (Para la minería Bitcoin, cambie la velocidad a PCI-E 1.0 en la configuración del BIOS) Ranura 1x PCIe 3.0 x16 : Cuando se utiliza APU o NPU, el ancho de banda es x8 velocidad
Panel trasero de E/S	Ratón 1x PS/2 Teclado 1x PS/2 Ranura 1x DVI-D Ranura 1x LAN Ranura 4x USB 3.1 Gen1 (5Gb/s) Ranura 2x USB 2.0 (Sólo 5V de potencia) Ranura 2x USB 2.0 Socket audio 3x
Conectores en placa	Conector 4x SATA III 6Gb's Distribuidor 2x USB 2.0 (cada distribuidor soporta 2 ranuras USB 2.0) Distribuidor 1x USB 3.1 Gen1 (5Gb/s) - (cada distribuidor soporta 2 ranuras USB 3.1 Gen1) Conector con 8 patillas x1 Conector con 24 patillas x1 Conector con 4 patillas x2 (Para la minería de Bitcoin, se debe instalar un conector de alimentación de 4 pines) Conector de alimentación SATA de 15 pines x1 (Para el aumento de potencia USB) Conector Ventilador procesador x1 Conector Ventilador Sistema x1 Distribuidor Panel Frontal x1 Distribuidor Audio Frontal x1 Distribuidor Ranura Serie x1 Distribuidor CMOS Directo x1
Factor de Forma	Factor de Forma ATX, 295 mm x 210 mm
SopORTE OS	Windows 7(64bit) / 10(64bit) Biostar reserva su derecho de añadir o retirar el soporte para cada OS con o sin notificación.



## Thai

คุณสมบัติ	
ซีพียู	ซี็อกเก็ต AM4 สนับสนุน AMD A-series APU / CPU CPU TDP (Thermal Design Power) สูงสุด: 95Watt * เข้าชมได้ที่ <a href="http://www.biostar.com.tw">www.biostar.com.tw</a> สำหรับรายการซีพียูที่สนับสนุน
ชิพเซ็ต	AMD B350 (TB350-BTC) AMD A320 (TA320-BTC)
หน่วยความจำ	สนับสนุน Dual Channel DDR4 1866/2133/2400/2667 รองรับหน่วยความจำ 2 สล็อต DDR4 DIMM สูงสุดถึง 32 GB ทุก DIMM สนับสนุนโมดูล non-ECC & ECC 4/8/16 GB DDR4 * DDR4 - 2667 เฉพาะสำหรับ Ryzen CPU * เข้าชมได้ที่ <a href="http://www.biostar.com.tw">www.biostar.com.tw</a> สำหรับรายการหน่วยความจำที่สนับสนุน
สต่อเร็ว	4x SATA III พอร์ตเชื่อมต่อ (6Gb/s) : สนับสนุน AHCI & RAID 0,1,10
แลน	Realtek RTL 8111H 10/ 100/ 1000 Mb/s การเจรจาอัตโนมัติ, ความสามารถในการเพ็ล็กซ์ Half / Full
ออดิโอ โคเดก	ALC887 7.1 Channels, High Definition Audio
ยูเอสบี	6x USB 3.1 Gen1 (5Gb/s) พอร์ต (4 พอร์ตด้านหลัง I/O และ 2 พอร์ต ผ่านพอร์ตเชื่อมต่อด้านใน) 6x USB 2.0 พอร์ต (2 พอร์ตด้านหลัง I/O และ 4 พอร์ต ผ่านพอร์ตเชื่อมต่อภายใน)
สล็อตขยายเพิ่มเติม	3x PCIe 2.0 x1 สล็อต 2x PCIe 3.0 x1 สล็อต (สำหรับการทำเหมือง Bitcoin, เปลี่ยนความเร็วในการ PCI-E 1.0 ในการตั้งค่า BIOS) 1x PCIe 3.0 x16 สล็อต : เมื่อใช้ APU หรือ NPU แบนด์วิดท์คือความเร็ว x8
พอร์ต I/O ด้านหลัง	1x PS/2 เมาส์ 1x PS/2 คีย์บอร์ด 1x DVI-D พอร์ต 1x LAN พอร์ต 4x USB 3.1 Gen1 (5Gb/s) พอร์ต 2x USB 2.0 พอร์ต (เพียง 5V พลังงาน) 2x USB 2.0 พอร์ต 3x Audio Jack
พอร์ต I/O ด้านใน	4x SATA III 6Gb/s พอร์ตเชื่อมต่อ 2x USB 2.0 พอร์ตเชื่อมต่อ (หัวเชื่อมต่อทุกตัวรองรับ 2 พอร์ต USB 2.0) 1x USB 3.1 Gen1 (5Gb/s) พอร์ตเชื่อมต่อ (หัวเชื่อมต่อทุกตัวรองรับ 2 พอร์ต USB 3.1 Gen1) 1x 8-Pin Power พอร์ตเชื่อมต่อ 1x 24-Pin Power พอร์ตเชื่อมต่อ 2x 4-Pin Power พอร์ตเชื่อมต่อ (สำหรับการทำเหมือง Bitcoin, ขั้วต่อสายไฟ 4 PIN จะต้องติดตั้ง) 1x 15-Pin SATA Power พอร์ตเชื่อมต่อ (สำหรับการเพิ่มประสิทธิภาพไฟ USB) 1x พอร์ตเชื่อมต่อ CPU Fan 1x พอร์ตเชื่อมต่อระบบ Fan 1x พอร์ตเชื่อมต่อแผงด้านหน้า 1x พอร์ตเชื่อมต่อออดิโอด้านหน้า 1x พอร์ตเชื่อมต่อ Serial Port 1x พอร์ต Clear CMOS
รูปแบบจากโรงงาน	ขนาด ATX จากโรงงาน, 210 มม. x 295 มม.
สนับสนุน OS	Windows 7(64bit) / 10(64bit) Biostar ขอสงวนสิทธิ์ในการเพิ่มหรือถอดการสนับสนุนสำหรับระบบปฏิบัติการ OS ต่างๆ โดยไม่ต้องแจ้งให้ทราบล่วงหน้า

this page intentionally left blank

## FCC条款

依照FCC条款第15部分的规定，本装置已经通过测试并且符合Class B级数字装置的限制。此条款限制了在安装过程中可能造成的有害射频干扰并提供了合理的防范措施。本装置在使用时会产生无线射频辐射，如果没有依照本手册的指示安装和使用，可能会与无线通讯装置产生干扰。然而，并不保证在特定的安装下不会发生任何干扰。

如果关闭和重新开启本设备后，仍确定本装置造成接收广播或电视的干扰，用户可以使用以下列表中的一种或多种方法来减少干扰：

- 重新安装或调整接收天线。
- 增加本设备与接收设备之间的距离。
- 连接设备连接到不同的插座以便于两个设备使用不同的回路。
- 咨询经销商或富有经验的无线电工程师，以获得更多资讯。

本用户手册内容的变更，恕不另行通知，制造商没有解释的义务。

本用户手册的所有内容若有任何错误，制造商没有义务为其承担任何责任。所有商标和产品名称均有其各自所有权。

未经过书面许可，不得以任何形式（部分或全部）复制此手册信息。

## 免责声明

本手册内容系BIOSTAR®知识产权，版权归BIOSTAR®所有。我们本着对用户负责的态度，精心地编写该手册，但不保证本手册的内容完全准确无误。BIOSTAR®有权在不知会用户的前提下对产品不断地进行改良、升级及对手册内容进行修正，实际状况请以产品实物为准。本手册为纯技术文档，无任何暗示及影射第三方之内容，且不承担排版错误导致的用户理解歧义。本手册中所涉及的第三方注册商标所有权归其制造商或品牌所有人。



### CE符合性简短声明

我们声明此产品符合现行标准，并满足2004/108/CE、2006/95/CE 和1999/05/CE指令规定的所有基本要求。

## 防静电操作规则

静电可能严重损坏您的设备，在处理主板以及其它的系统设备的时候要特别注意，避免和主板上的系统组件的不必要接触，保证在抗静电的环境下工作，避免静电放电可能对主板造成损坏，当在您的机箱中插入或者移除设备时，请保证电源处于断开状态，厂商对于不遵照本操作规则或者不遵守安全规范而对主板造成的损坏不负责。



**警告**  
主板易受静电损坏  
请遵守操作规则



# 目录

<b>第一章: 主板介绍 .....</b>	<b>3</b>
1.1 前言 .....	3
1.2 包装清单 .....	3
1.3 主板特性 .....	4
1.4 后置面板接口 .....	5
1.5 主板布局图 .....	6
<b>第二章: 硬件安装 .....</b>	<b>7</b>
2.1 中央处理器(CPU) .....	7
2.2 散热片 .....	8
2.3 风扇接头 .....	10
2.4 系统内存 .....	10
2.5 扩展槽 .....	12
2.6 跳线设置 .....	13
2.7 接口和插槽 .....	14
<b>第三章: UEFI BIOS和软件 .....</b>	<b>18</b>
3.1 UEFI BIOS设置 .....	18
3.2 刷新BIOS .....	18
3.3 软件 .....	22
<b>第四章: 帮助信息 .....</b>	<b>25</b>
4.1 驱动程序安装注意事项 .....	25
4.2 AMI BIOS 哔声代码 .....	26
4.3 问题解答 .....	26
4.4 RAID 功能 .....	27
<b>附录I : 产品中有毒有害物质或元素的名称及含量 .....</b>	<b>29</b>

# 第一章: 主板介绍

## 1.1 前言

感谢您选购我们的产品。在开始安装主板前，请仔细阅读以下安全指导说明：

- 选择清洁稳定的工作环境。
- 操作前请确保计算机断开电源。
- 从防静电袋取出主板之前，先轻触安全触地器或使用触地手腕带去除静电以确保安全。
- 避免触摸主板上的零件。手持电路板的边缘，不要弯曲或按压电路板。
- 安装之后，确认没有任何小零件置于机箱中，一些小的零件可能引起电流短路并可能损坏设备。
- 确保计算机远离危险区域，如：高温、潮湿、靠近水源的地方。
- 计算机的工作温度应保持在0-45°C之间
- 为避免受伤，请注意以下幾點：  
主板或连接器上尖銳的針腳  
机箱上的粗糙边缘和尖角  
破损的线缆可能引起短路

## 1.2 包装清单

- Serial ATA数据线 x2
- ATX机箱后置I/O面板 x1
- 用户手册 x1
- 驱动光盘 x1 (包括安装驱动)

---

### 注意

» 此清单可能因销售区域或主板型号不同而异，相关标配详情请咨询当地经销商。

---

## 1.3 主板特性

规格	
CPU支援	Socket AM4 支持 AMD A-系列 APU / CPU CPU TDP ( 散热设计功耗 ) 最大值 : 95瓦 请访问 <a href="http://www.biostar.com.tw">www.biostar.com.tw</a> 获取CPU的支持列表。
芯片组	AMD B350 (TB350-BTC) AMD A320 (TA320-BTC)
内存	支持双通道DDR4 1866/2133/2400/2667 2个DDR4 DIMM插槽 · 最大内存容量为32GB 每个DIMM支持非ECC & ECC 4/ 8/ 16 GB DDR4内存模组 * DDR4 - 2667仅限于Ryzen CPU。 * 请访问 <a href="http://www.biostar.com.tw">www.biostar.com.tw</a> 获取内存的支持列表。
存储器	4个SATA III接口 (6Gb/s) : 支持 AHCI & RAID 0 · 1 · 10
网络	Realtek RTL 8111H 10/ 100/ 1000 Mb/s自适应传输模式 · 半双工/全双工工作模式
音效	ALC887 8声道音频输出 · 支持高清音频
USB	6个USB 3.1 Gen1 (5Gb/s) 端口(背板4个端口 · 板载接头支持2个端口) 6个USB 2.0端口(背板2个端口 · 板载接头支持4个端口)
扩展槽	3个PCIe 2.0 x1插槽 2个PCIe 3.0 x1插槽 (当使用比特币挖矿时 · 请在BIOS设置中将速度更改为PCI-E 1.0) 1个PCIe 3.0 x16插槽 : 当使用APU或NPU时 · 带宽为 x8模式
背板接口	1个PS/2鼠标接口 1个PS/2键盘 1个DVI-D端口 1个LAN端口 4个USB3.1 Gen1 (5Gb/s)端口 2个USB2.0端口 (仅提供5V电源) 2个USB2.0端口 3个音频插孔
板载接口	4个SATA III接口 (6Gb/s) 2个USB2.0接头(每个接头支持2个USB2.0端口) 1个USB3.1 Gen1 (5Gb/s)接头(每个接头支持2个USB3.1 Gen1端口) 1个电源接口(8针) 1个电源接口(24针) 2个电源接口(4针) (当使用比特币挖矿时 · 必须安装4pin电源连接器) 1个SATA电源接口(15针) (增强USB电源) 1个CPU风扇接头 1个系统风扇接头 1个前置面板接头 1个前置音频接头 1个串行端口接头 1个清空CMOS数据接头
主板尺寸	ATX Form Factor · 295 mm x 210 mm
操作系统支持	Windows 7(64bit) / 10(bit) * 如有增加或减少任何OS支持 · Biostar保留不预先通知的权利。

## 1.4 后置面板接口

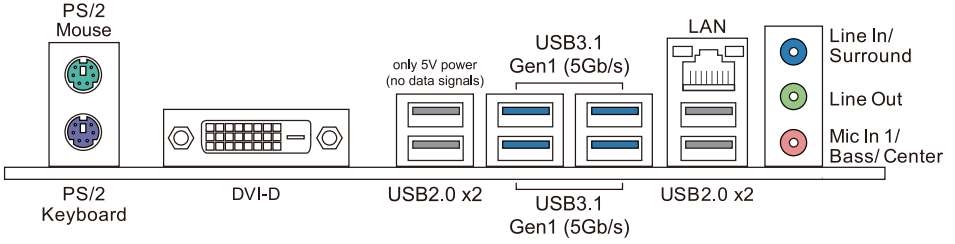

### 注意

- » 带集成显卡的AMD系列处理器才支持DVI-D输出端口。
- » 由于音频芯片支持高保真音频规格，各音频插座的功能由软件定义，上面所列出的各音频插孔的输入/输出功能表示其默认设置。当连接外部麦克风到音频接口时，请使用Line In（蓝色）和Mic In（粉红色）插孔。
- » 最高分辨率：  
DVI-D: 1920 x 1200 @60Hz
- » 当使用前置HD音频插孔并插入耳机/麦克风时，后置声音将自动禁用。

## 1.5 主板布局图

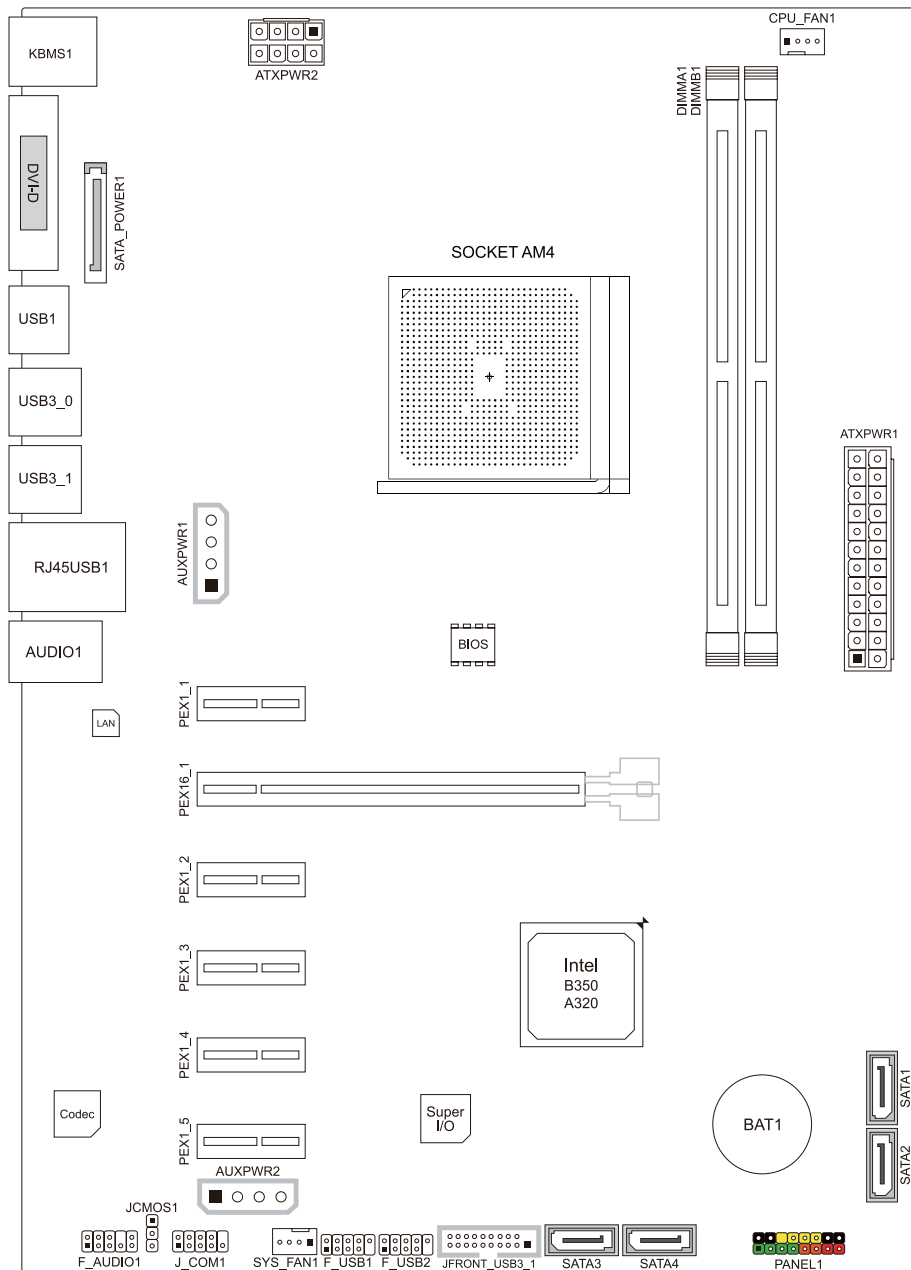

**注意**

» ■ 标示为针脚1



## 第二章: 硬件安装

### 2.1 中央处理器(CPU)

步骤1: 找到主板上的CPU插槽。

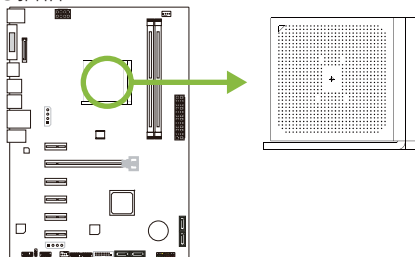

步骤2: 将固定拉杆从插槽处水平拉起至90度。

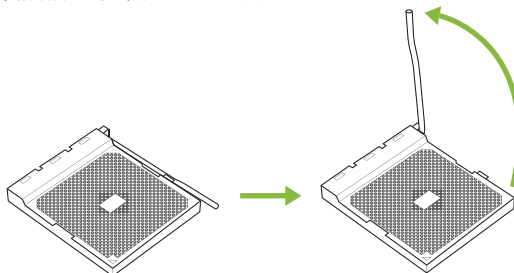

步骤3: 找到插槽上的白色三角，CPU上的金点应指向此白色三角，CPU必须按正确的方向放入。

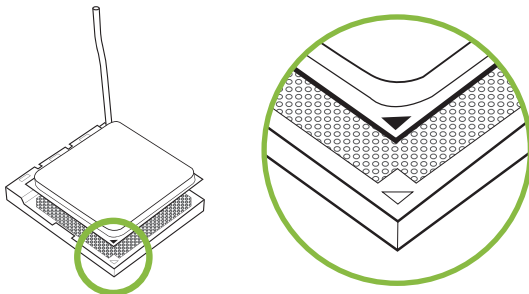

步骤4: 固定CPU，将拉杆闭合。

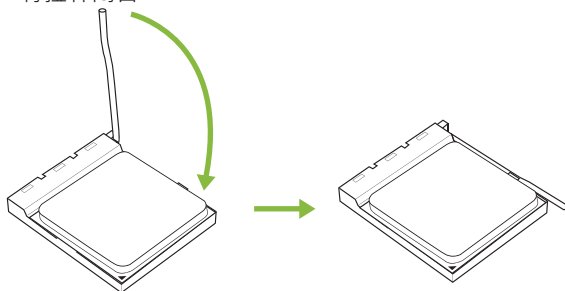

**注意**

» 请于拔除CPU插槽之前，关闭电源。

## 2.2 散热片

### <类型A>

步骤 1: 将散热片和风扇组件放置在支架上。散热片夹对准插座固定凸耳，再将弹簧夹扣到固定凸耳上。

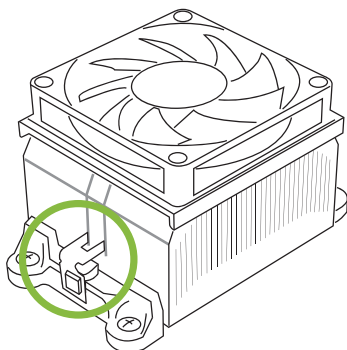

步骤2: 将另一边的固定夹向下压，扣住支架上的塑胶凸耳。然后固定，使风扇和散热片扣住支架底座。

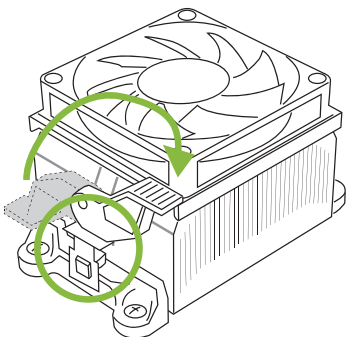

## &lt;类型B&gt;

步骤 1: 取下主板上的散热片和风扇组件支架, 并保留散热风扇的铁背板于主板下方。

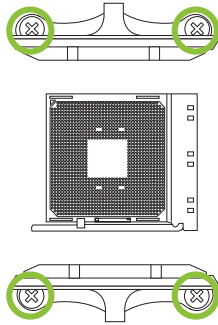

步骤 2: 将散热片和风扇组件放置于CPU上方, 调整方向使风扇电缆最靠近CPU风扇连接器, 参照示意图之顺序将螺丝锁入, 完成散热片风扇的安装。

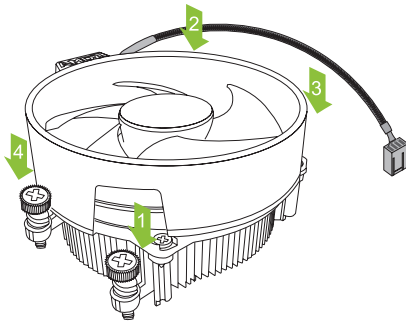
**注意**

- » 请务必连接CPU风扇接口。
- » 请参照CPU散热片的安装手册获取正确的安装信息。

## 2.3 风扇接头

此风扇接头支持电脑内置的冷却风扇，风扇引线和插头可能因制造商而异。

### CPU\_FAN1: CPU 风扇接头

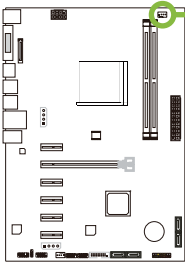

针	定义
1	接地
2	+12V
3	FAN RPM rate sense
4	Smart Fan Control (By Fan)

### SYS\_FAN1: 系统风扇接头

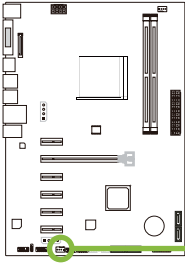

针	定义
1	接地
2	+12V
3	FAN RPM rate sense
4	Smart Fan Control (By Fan)

#### 注意

- » CPU\_FAN1·SYS\_FAN1支持4针脚和3针脚接口；接线时请注意红线是正极需接到第二个针脚，黑线接地需接到GND针脚。

## 2.4 系统内存

### DDR4内存模组

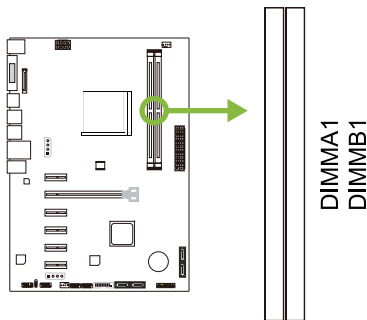

DIMM1  
DIMM2

步骤1: 向外推开固定夹，打开DIMM插槽。将DIMM按顺序放在插槽上，DIMM上的切口须与插槽凹口匹配。

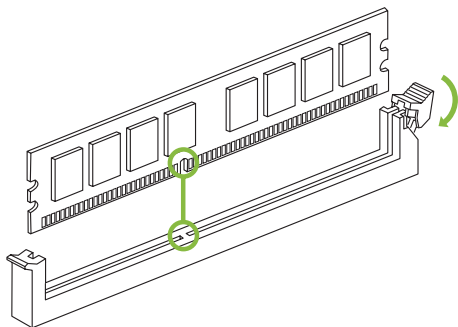

步骤2: 垂直插入DIMM并固定好，直到固定夹跳回原位，DIMM就位。

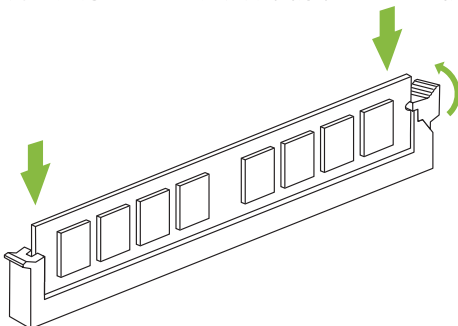

#### 注意

» 如果DIMM未顺利插入，请勿强行按压。将DIMM拔出，再重插一次。

## 内存容量

DIMM插槽位置	模组	总内存
DIMMA1	4GB/8GB/16GB	最大为 32GB.
DIMMB1	4GB/8GB/16GB	

## 双通道内存安装

为激活主板双通道功能，使用内存模组必须符合以下要求：成对安装相同密度的内存模组。如下表所示

双通道状态	DIMMA1	DIMMB1
Disabled	○	X
Disabled	X	○
Enabled	○	○

(“○”表示内存已安装，“X”表示内存未安装。)

#### 注意

» 当安装多个内存模块时，我们建议使用相同品牌和容量的内存安装于主板上。

## Ryzen - DDR最高频率支持表

最高频率	DIMMA1	DIMMB1
DDR4-2667	SR	--
DDR4-2667	DR	--
DDR4-2667	SR	SR
DDR4-2400	DR	DR

### 注意

- » SR - Single-rank DIMM, 1R x4 or 1R x8。
- » DR - Dual-rank DIMMs, 2R x4 or 2R x8。
- » 为了更好的DDR4模块兼容性，请按照上述列表安装您的DDR4模块。

## 2.5 扩展槽

### PEX16\_1: PCI-Express Gen3 x16 插槽

#### (APU / CPU @x8 模式, Ryzen @x16 模式)

- 符合PCI-Express 3.0规范。
- 同步单向最大理论带宽为16GB/s，总带宽为32GB/s。

### PEX1\_1/1\_2: PCI-Express Gen3 x1 插槽

- 符合PCI-Express 3.0规范。
- 同步单向最大理论带宽为1GB/s，总带宽为2GB/s。

### PEX1\_3/1\_4/1\_5: PCI-Express Gen2 x1 插槽

- 符合PCI-Express 2.0规范。
- 同步单向最大理论带宽为500MB/s，总带宽为1GB/s。

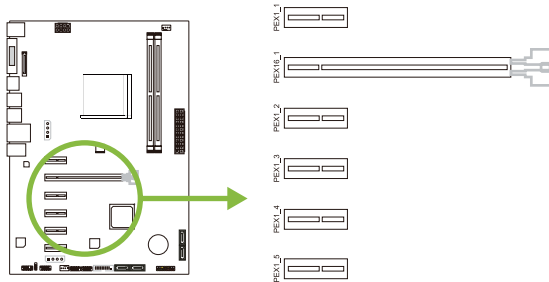

## 安装扩展卡

请参照以下步骤安装扩展卡：

- 安装扩展卡前请阅读扩展卡的相关指示说明。
- 打开电脑机箱后盖，移除螺丝和插槽支架。
- 将扩展卡按照正确的方向插入插槽，直到扩展卡完全就位。
- 用螺丝将扩展卡的金属支架固定到机箱后置面板。
- 还原电脑机箱后盖。
- 开机。如有必要，可为扩展卡更改BIOS设置。
- 安装扩展卡的驱动。

## 2.6 跳线设置

下图展示如何设置跳线。当跳帽放置在针脚上时，跳线为闭合(close)状态。否则跳线为断开(open)状态。

Pin 打开



Pin 闭合



Pin 1-2 闭合



### JCMOS1: 清空CMOS 跳线

用户可清空CMOS数据并恢复BIOS安全设置，请按照以下步骤操作以免损坏主板。

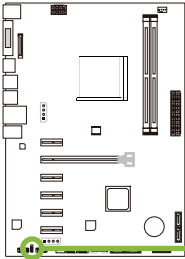

Pin 1-2 闭合: 正常操作(默认)



Pin 2-3 闭合: 清空CMOS数据

#### 清空CMOS数据过程:

1. 断开AC电源。
2. 将跳线设置成2-3接脚闭合。
3. 等待5秒钟。
4. 将跳线设置成1-2接脚闭合。
5. 接通AC电源。
6. 开机然后按下<Del>键进入BIOS设置。

## 2.7 接口和插槽

### ATXPWR1: ATX电源接口

为了更好的兼容性，我们建议使用标准的ATX24-pin电源供应此接口的电源。

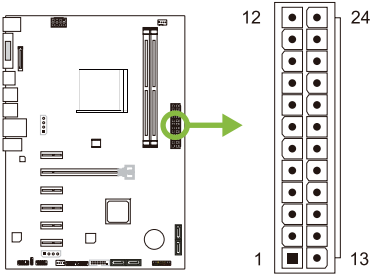

针	定义	针	定义
13	+3.3V	1	+3.3V
14	-12V	2	+3.3V
15	接地	3	接地
16	PS_ON	4	+5V
17	接地	5	接地
18	接地	6	+5V
19	接地	7	接地
20	NC	8	PW_OK
21	+5V	9	唤醒电压+5V
22	+5V	10	+12V
23	+5V	11	+12V
24	接地	12	+3.3V

### ATXPWR2: ATX电源接口

此接口给CPU电路提供+12V电压。若CPU电源插头为4针脚，请将其插入ATXPWR2的1-2-5-6针脚。

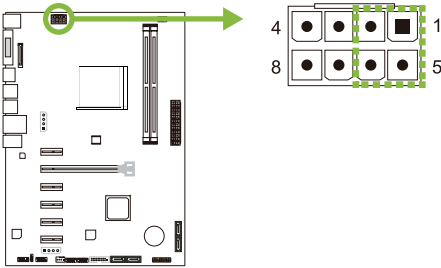

针	定义
1	+12V
2	+12V
3	+12V
4	+12V
5	接地
6	接地
7	接地
8	接地

#### 注意

- » 开机前，请确保ATXPWR1和ATXPWR2接口都已插上电源。
- » 电压不足可能导致系统不稳或者外围设备不能正常运行。当配置使用大功率设备的系统时，建议您使用带有大功率输出的电源。

### AUXPWR1/2: 图形辅助电源连接器

(当比特币挖矿使用时，必须安装4pin电源连接器)

此连接器是用于显卡的辅助电源连接。显卡的独占电源提供更好的图形性能。

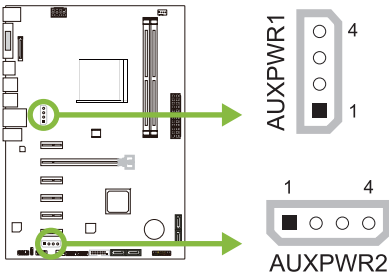

针	定义
1	+12V
2	接地
3	接地
4	+5V



## SATA\_POWER1: SATA电源接口

此SATA电源连接器增强后端USB端口的电源。

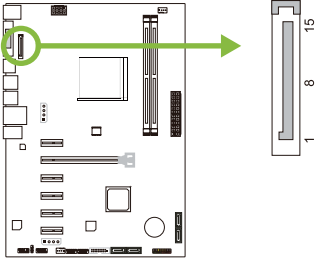

针	定义	针	定义
1	VCC3	9	VCC5
2	VCC3	10	接地
3	VCC3	11	N/A
4	接地	12	接地
5	接地	13	12V
6	接地	14	12V
7	VCC5	15	12V
8	VCC5	--	--

## PANEL1: 前置面板接头

此16针脚接口包含开机·重启·硬盘指示灯·电源指示灯和扬声器接口。

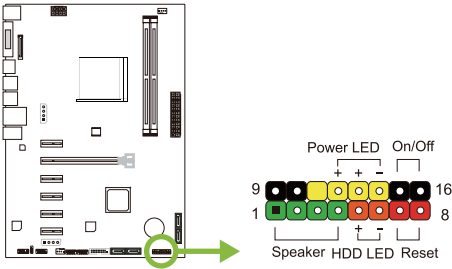

针	定义	功能	针	定义	功能
1	+5V	扬声器接口	9	N/A	N/A
2	N/A		10	N/A	
3	N/A		11	N/A	
4	扬声器	硬盘指示灯	12	Power LED (+)	电源指示灯
5	HDD LED (+)		13	Power LED (+)	
6	HDD LED (-)	重启按钮	14	Power LED (-)	开机按钮
7	接地		15	电源按钮	
8	Reset control	16	接地		

## SATA1~SATA4: 串行ATA 6.0 Gb/s 接口

此接口通过SATA数据线连接SATA硬盘。

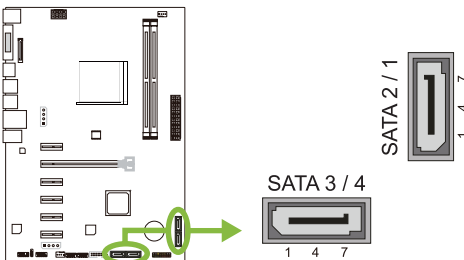

针	定义
1	接地
2	TX+
3	TX-
4	接地
5	RX-
6	RX+
7	接地

## JFRONT\_USB3\_1: 前置面板USB 3.1 Gen1 (5Gb/s)接头

PC前置面板支持附加的USB数据线，也可连接即插即用外围设备。

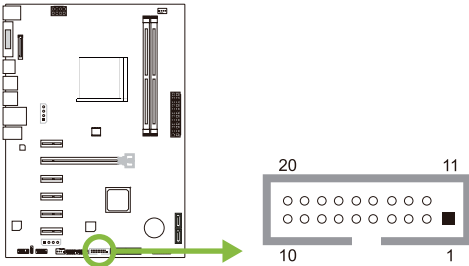

针	定义	针	定义
1	VBUS0	11	D2+
2	SSRX1-	12	D2-
3	SSRX1+	13	接地
4	接地	14	SSTX2+
5	SSTX1-	15	SSTX2-
6	SSTX1+	16	接地
7	接地	17	SSRX2+
8	D1-	18	SSRX2-
9	D1+	19	VBUS1
10	ID	20	Key

## F\_USB1/2: 前置面板USB 2.0接头

PC前置面板支持附加的USB数据线，也可连接即插即用外围设备。

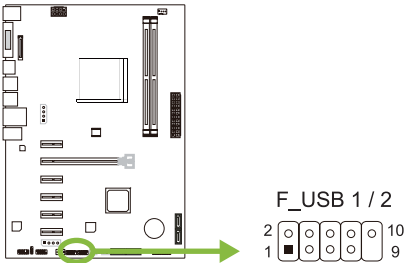

针	定义
1	+5V (fused)
2	+5V (fused)
3	USB-
4	USB-
5	USB+
6	USB+
7	接地
8	接地
9	Key
10	NC

## F\_AUDIO1: 前置面板音频接头

此接头可连接音频输出数据线，支持HD(高清)音频和AC' 97。

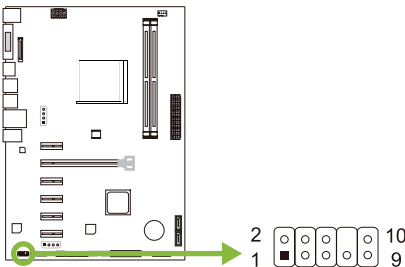

HD Audio		AC' 97	
针	定义	针	定义
1	Mic Left in	1	Mic In
2	接地	2	接地
3	Mic Right in	3	Mic Power
4	GPIO	4	Audio Power
5	Right line in	5	RT Line Out
6	Jack Sense	6	RT Line Out
7	Front Sense	7	Reserved
8	Key	8	Key
9	Left line in	9	LFT Line Out
10	Jack Sense	10	LFT Line Out

### 注意

- » 建议您连接前置高清音频插孔，享用主板高清音频功能。
- » 如果要连接AC' 97前置音频输出数据线，请关闭“前置面板插孔检测功能”。此功能在系统音频工具中可见。

## J\_COM1: 串行端口

此主板有一个串行端口可接出RS-232接头。

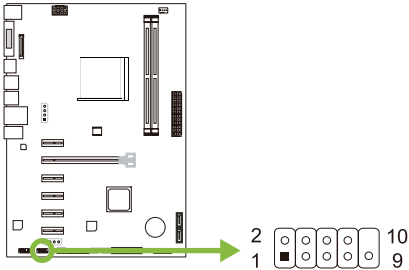

Pin	Assignment
1	Carrier detect
2	Received data
3	Transmitted data
4	Data terminal ready
5	Signal ground
6	Data set ready
7	Request to send
8	Clear to send
9	Ring indicator
10	Key

## 第三章: UEFI BIOS和软件

### 3.1 UEFI BIOS设置

- BIOS设置程序可用于查看和更改计算机的BIOS设置。开机自检时，按<DEL>键可进入BIOS设置程序。
- 更多相关UEFI BIOS设置信息，请参考网站上的UEFI BIOS手册。

### 3.2 刷新BIOS

以下任意一种工具都可以刷新BIOS:

- BIOSTAR BIOS Flasher: 使用此工具，BIOS可通过硬盘上的文件刷新，USB驱动刷新，或者CD-ROM 刷新。
- BIOSTAR BIOS刷新工具: 能够在Windows 环境下自动刷新。使用此工具，BIOS可通过硬盘上的文件刷新，USB驱动刷新，CD-ROM 刷新或者从网站上的文件地址刷新。

#### BIOSTAR BIOS Flasher

##### 注意

- » 此工具仅允许可使用FAT32/16格式化或单个分区的存储设备。
- » 刷新BIOS时如关机或重启系统将导致系统引导失败。

使用BIOSTAR BIOS Flasher刷新BIOS

1. 进入网站下载与主板相匹配的最新BIOS文件。
2. 然后保存BIOS文件到U-盘。(仅支持FAT/FAT32格式)
3. 插入包含BIOS文件的U-盘到USB接口
4. 开机或重启后，在自检过程中按<F12>键。

5. 进入自检后，屏幕会弹出BIOS-FLASHER工具。选择<fs0>搜索BIOS文件。

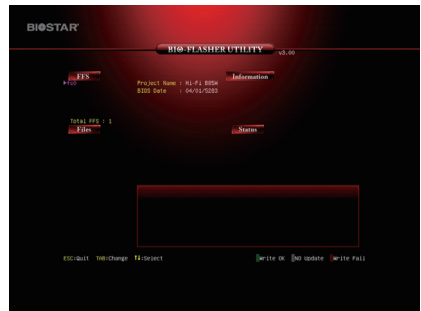

6. 选择合适的BIOS文件，并按“ Yes” 执行BIOS刷新程序。



7. BIOS刷新后会弹出是否重启系统的对话框。按<Y>重启系统

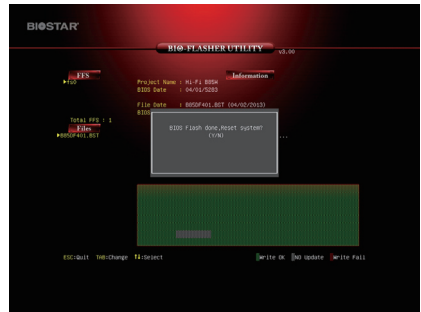

8. 系统引导并出现相关标识信息时，按<DEL>键进入BIOS设置。选择<Save & Exit>，使用<Restore Defaults>功能加载系统默认值，然后选择<Save Changes and Reset>来重启系统，完成BIOS刷新。

### BIOS刷新工具（通过网络）

1. 用DVD驱动安装BIOS Update Utility。
2. 使用此功能时，请确保电脑联网。

3. 打开BIOS刷新工具，然后点击“ Online Update”按钮。



4. 屏幕弹出是否执行刷新BIOS程序的对话框，点击“ Yes”开始刷新BIOS。

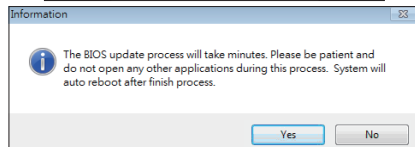

5. 如果BIOS有新版本，屏幕会弹出提示您下载最新版本的对话框。点击“ Yes”下载。

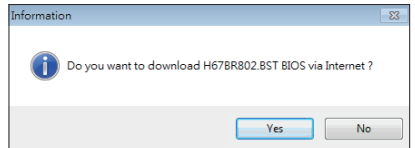

6. 完成下载后，屏幕弹出提示您刷新BIOS的对话框，点击“ Yes”开始刷新。

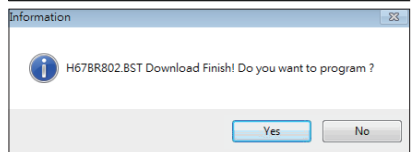

7. 刷新程序结束后，屏幕弹出提示您重启系统的对话框。点击“OK”重启系统。

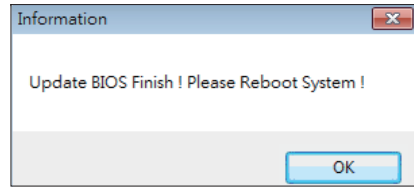

8. 系统引导并出现相关标识信息时，按<DEL>键进入BIOS设置。选择<Save & Exit>，使用<Restore Defaults>功能加载系统默认值，然后选择<Save Changes and Reset>来重启系统，完成BIOS刷新。

### BIOS刷新工具（通过BIOS文件）

1. 用DVD驱动安装BIOS刷新工具。
2. 从我们的网站[www.biostar.com.tw](http://www.biostar.com.tw) 下载合适的BIOS。

3. 在主页面上打开BIOS Updat Utility，然后点击“Update BIOS”按钮。



4. 屏幕弹出是否执行刷新BIOS程序的对话框，点击“OK”开始刷新BIOS。

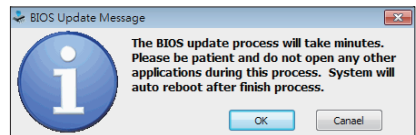

5. 选择BIOS文件的存放目录。然后选择合适的BIOS文件，点击“Open”。  
刷新BIOS要花几分钟时间，请耐心等待。



6. BIOS刷新过程结束后，点击“OK”重启系统。

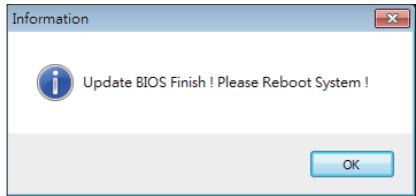

7. 系统引导并出现相关标识信息时，按<DEL>键进入BIOS设置。  
选择<Save & Exit>，使用<Restore Defaults>功能加载系统默认值，然后选择<Save Changes and Reset>来重启系统，完成BIOS刷新。

### BIOS备份

点击BIOS备份按钮，选择存储备份文件的合适目录，然后点击“Save”。

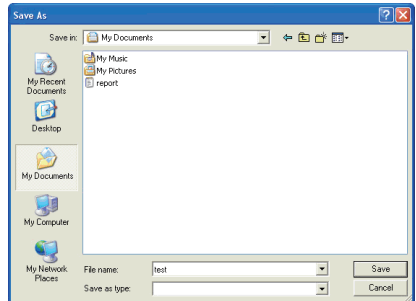

### 3.3 软件

#### 安装软件

1. 将光盘放入光驱，若Autorun功能已激活，驱动安装程序将会出现。
2. 选择Software Installation，然后点击各软件图标。
3. 根据屏幕上的指令完成安装。

#### 启动软件

安装程序完成后，桌面上将出现软件图标。请双击图标启动软件工具。

#### 注意

- » 所有软件的相关信息和内容若有变更，恕不另行通知。为使系统性能更佳，软件会不断升级。
- » 下面的图片和信息仅供参考，此主板的实际信息和设置可能与手册稍有差异。

#### BIOScreen 工具

此实用工具可以将开机画面个性化。您可以选择BMP格式来自定义计算机开机画面。



请参照以下步骤来更新开机画面：

- 加载画面(Load Image)：选择图片作为开机画面。
- 转换(Transform)：转换图片并预览。
- 更新BIOS(Update Bios)：将图片写入BIOS内存，然后完成更新。



## eHot-Line

eHot-Line是有助于您联系技术支持系统的便捷工具。此工具将收集系统信息，当您遇到问题时，可提供有利分析，并发送这些信息至我们的技术支持部门，从而帮助解决问题。

\* represents important information that you must provide. Without this information, you may not be able to send out the mail.

This block will show the information which would be collected in the mail.

\* Describe condition of your system.

Annotations for the eHot-Line interface:

- Base board information :  
Caption : Base Board  
CreationClassName : Win32\_Base Board  
Description : Base Board  
HostingBoard : TRUE  
HotSwappable : FALSE  
Manufacturer : BIOSTAR Group  
Name : Base Board  
PoweredOn : TRUE  
Product : TA780G M2+  
Removable : FALSE  
Replaceable : TRUE  
RequiresDaughterBoard : FALSE  
SerialNumber : None  
Status : OK  
Tag : Base Board  
Version : 6.0
- Symptom Description :
- Region :
- CC E-mail :
- Memory Module Manufacture :
- Power Supply Manufacture/model :
- Send
- Save As...
- Exit

Additional annotations:

- Select your area or the area close to you.
- Provide the e-mail address that you would like to send the copy to.
- Provide the name of the memory module manufacturer.
- Provide the name of the power supply manufacturer and the model no.
- Send the mail out.
- Exit this dialog.
- Save these information to a .txt file

填好表格信息后，点击“Send”发送邮件。将出现一个确认信息对话框；点击“Send”确认发送，点击“Do Not Send”则取消操作。

如您想保存此信息到文本文件里，点击“Save As...” ，出现一个保存对话框，输入文件名即可。

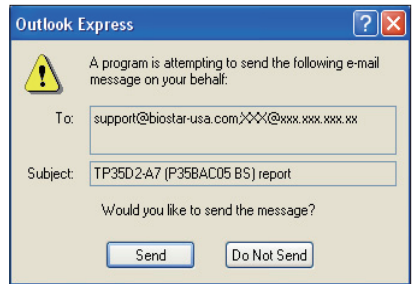

输入文件名，点击“Save”，系统信息将被保存至文本文件里。

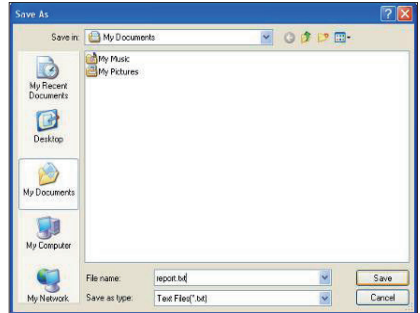

打开已保存的文本文件，显示相关系统信息（包括主板/BIOS/CPU/视频设备/OS）。这些信息当然也在已发送的邮件里。

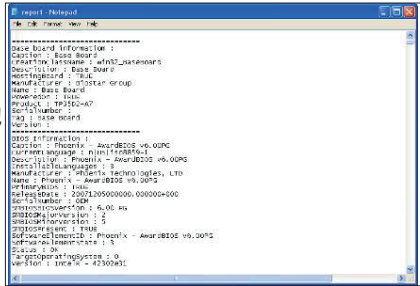

#### 注意

- » 在使用此工具前，请将Outlook Express设置为您的默认电子邮件连接程序。
- » 我们将为用户资料保密，所以使用eHot-Line服务时，请放心提供您的系统信息。
- » 若您未将Outlook Express设置为默认电子邮件连接程序，也可保存您的系统信息到文件里，然后用其它电子邮件工具发送此文件到我们的技术支持。  
请访问网站<http://www.biostar.com.tw/app/en/about/contact.php>获取我们的联系信息。

## 第四章:帮助信息

### 4.1 驱动程序安装注意事项

为获得更好的系统性能，在操作系统安装完成后，请插入您的系统驱动到光驱并安装。插入DVD后，将出现如下所示窗口。



此设置向导将自动检测您的主板和操作系统。

#### **A. 驱动程序安装**

安装驱动程序，请点击驱动器图标。设置向导将列出主板兼容驱动和操作系统。点击各设备驱动程序，以开始安装进程。

#### **B. 软件安装**

安装软件，请点击软件图标。设置向导将列出系统可用软件，点击各软件名称，以开始安装进程。

#### **C. 使用手册**

除了书本形式的手册，我们也提供光盘形式的使用指南。点击Manual图标，浏览可用相关使用指南。

#### **注意**

- » 在插入驱动之后，如此窗口未出现，请用文件浏览器查找并执行SETUP.EXE文件。
- » 若需要Acrobat Reader打开manual文件。请从网站<http://get.adobe.com/reader/>下载最新版本的Acrobat Reader软件。

## 4.2 AMI BIOS 哔声代码

### 引导模块哔声代码

哔声次数	含义
持续哔声	持续哔声

### BIOS 开机自检哔声代码

哔声次数	含义
1	系统引导成功
8	显存错误(系统视频适配器)

## 4.3 问题解答

问题	解决方法
1. 系统没有电，电源指示灯不亮，电源风扇不转动。 2. 键盘上的指示灯不亮。	1. 确定电源线是否接好。 2. 更换线材。 3. 联系技术支持。
系统不起作用。键盘指示灯亮，电源指示灯亮，硬盘正常运作。	用力按压内存两端，确保内存安置于插槽中。
系统不能从硬盘启动，能从光盘启动。	1. 检查硬盘与主板的连线，确定各连线是否确实接好，检查标准CMOS设置中的驱动类型。 2. 硬盘随时都有可能坏掉，所以备份硬盘数据是很重要的。
系统只能从光盘启动。硬盘能被读，应用程序能被使用，但是不能从硬盘启动。	1. 备份数据和应用程序。 2. 重新格式化硬盘。用后备盘重新安装应用程序和数据。
屏幕提示“Invalid Configuration”或“CMOS Failure”。 再次检查系统设备，确定设定是否正确 安装了第二个硬盘	再次检查系统设备，确定设定是否正确
安装了第二个硬盘后，系统不能启动。	1. 正确设置主/从硬盘跳线。 2. 运行安装程序，选择正确的驱动类型。 与驱动器厂商联系，寻求驱动兼容性的技术支持。

### CPU过热保护系统

在开启系统数秒后如有自动关机的现象，这说明CPU保护功能已被激活。CPU过热时，防止损坏CPU，主机将自动关机，系统则无法重启。

此种情况下，请仔细检查。

1. CPU 散热器平放在CPU表面。
2. CPU风扇能正常旋转。
3. CPU风扇旋转速度与CPU运行速度相符。

确认后，请按以下步骤缓解CPU保护功能。

1. 切断电源数秒。
2. 等待几秒钟。
3. 插上电源开启系统。

或是：

1. 清除CMOS数据。(查看“Close CMOS Header: JCMOS1”部分)
2. 等待几秒钟。
3. 重启系统。

## 4.4 RAID 功能

### RAID 定义

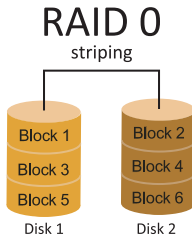

创建带区集，在同一时间内向多块磁盘写入数据，通过把数据分成多个数据块 (Block) 并行写入/读出多个磁盘以提高访问磁盘的速度分散到所有的硬盘中同时进行读写，在整个磁盘阵列建立过程中，以系统环境为基础，指数的大小决定了每块磁盘的容量。此技术可减少整个磁盘的存取时间和提供高速带宽。

### 性能及优点

- 驱动器: 最少2块硬盘，最长达6块或8块，取决于平台。
- Uses: 使用RAID 0来提高磁盘的性能和吞吐量，但没有冗余或错误修复能力。
- 优点: 增加磁盘的容量。
- 缺点: 整个系统是非常不可靠的，如果出现故障，无法进行任何补救，整个数据都会丢失。
- 容错: 否。

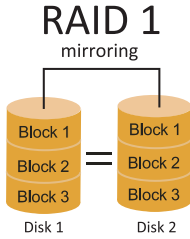

每次读写实际上是在磁盘阵列系统中(RAID 1)·通过2个磁盘驱动器并行完成的。RAID 1或镜像模式能够自动对数据进行备份·通过将一块硬盘中的数据完整复制到另外一块硬盘实现数据的冗余。假如由于硬盘的损坏·导致驱动失败·或是容量过大·RAID1可以提供一份数据备份。RAID 技术可以应用于高效方案·或者可以作为自动备份形式·代替冗长的·高价的且不稳定的备份形式。

### 性能及优点

- 驱动器: 最少2块硬盘·最多2块。
- 使用: RAID 1是理想的小型数据库储备器或应用在有容错能力和小容量方面。
- 优点: 提供100%的数据冗余。即使一个磁盘控制器出现问题·系统仍然可以使用另外一个磁盘控制器继续工作。
- 缺点: 2个驱动器替代一个驱动器储存的空间·在驱动重建期间系统的性能有所下降。
- 容错: 是。

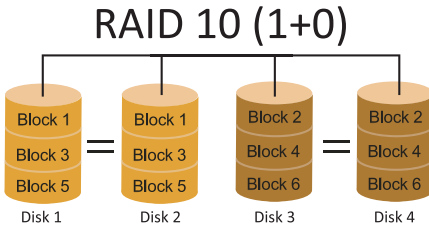

RAID 10模式是对RAID 0/ RAID 1两种不同模式的结合·可以同时支持带区集和镜像·这样既可以提升速度又可以加强数据的安全性。

### 性能及优点

- 驱动器: 最少4块硬盘·最多6或8块。
- 优点: 容量和性能的优化允许冗余的自动化。在一个阵列·可以同时使用其它的RAID·并允许剩余的磁盘。
- 缺点: 数据冗余需要两倍可用磁盘空间·与RAID1相同。
- 容错: 是。

## » 附录I：产品中有毒有害物质或元素的名称及含量

部件名称	有毒有害物质或元素					
	铅 (Pb)	汞 (Hg)	镉 (Cd)	六价铬 (Cr(VI))	多溴联苯 (PBB)	多溴二苯醚 (PBDE)
PCB板	○	○	○	○	○	○
结构件	○	○	○	○	○	○
芯片及其它主动零件	X	○	○	○	○	○
连接器	X	○	○	○	○	○
被动电子元器件	X	○	○	○	○	○
焊接金属	○	○	○	○	○	○
线材	○	○	○	○	○	○
助焊剂·散热膏·标签及其它耗材	○	○	○	○	○	○

○：表示该有毒有害物质在该部件所有均质材料中的含量在SJ/T11363-2006标准规定的限量要求以下。

X：表示该有毒有害物质至少在该部件的某一均质材料中的含量超出SJ/T11363-2006标准规定的限量要求。

备注：在芯片及其它主动零件、连接器、被动电子元器件Pb栏位中有打X，表示Pb在该部件的某一均质材料中的含量超出SJ/T11363-2006标准规定的限量要求，但均符合欧盟ROHS指令豁免条款。