

NF697 Series User Manual

NO. G03-NF697-F

Revision: 2.0

Release date: August 14, 2017

Trademark:

- * Specifications and Information contained in this documentation are furnished for information use only, and are subject to change at any time without notice, and should not be construed as a commitment by manufacturer.

Environmental Protection Announcement

Do not dispose this electronic device into the trash while discarding. To minimize pollution and ensure environment protection of mother earth, please recycle.



TABLE OF CONTENT

ENVIRONMENTAL SAFETY INSTRUCTION.....	iii
USER'S NOTICE	iv
MANUAL REVISION INFORMATION.....	iv
ITEM CHECKLIST	iv
CHAPTER 1 INTRODUCTION OF THE MOTHERBOARD	
1-1 FEATURE OF MOTHERBOARD.....	1
1-2 SPECIFICATION	2
1-3 PRODUCT DIAGRAM.....	4
CHAPTER 2 HARDWARE INSTALLATION	
2-1 LOCATION OF INTERNAL JUMPER AND CONNECTOR	5
2-2 INTERNAL JUMPER AND CONNECTOR SETTING.....	6
2-2-1 CONNECTORS	10
2-2-2 HEADERS	12
CHAPTER 3 INTRODUCING BIOS	
3-1 ENTERING SETUP	18
3-2 BIOS MENU SCREEN	19
3-3 FUNCTION KEYS	19
3-4 GETTING HELP	20
3-5 MEMU BARS.....	20
3-6 MAIN MENU	21
3-7 ADVANCED MENU.....	22
3-8 CHIPSET MENU.....	34
3-9 SECURITY MENU	37
3-10 BOOT MENU.....	38
3-11 SAVE & EXIT MENU	39



Environmental Safety Instruction

- Avoid the dusty, humidity and temperature extremes. Do not place the product in any area where it may become wet.
- 0 to 40 centigrade is the suitable temperature. (The temperature comes from the request of the chassis and thermal solution)
- Generally speaking, dramatic changes in temperature may lead to contact malfunction and crackles due to constant thermal expansion and contraction from the welding spots' that connect components and PCB. Computer should go through an adaptive phase before it boots when it is moved from a cold environment to a warmer one to avoid condensation phenomenon. These water drops attached on PCB or the surface of the components can bring about phenomena as minor as computer instability resulted from corrosion and oxidation from components and PCB or as major as short circuit that can burn the components. Suggest starting the computer until the temperature goes up.
- The increasing temperature of the capacitor may decrease the life of computer. Using the close case may decrease the life of other device because the higher temperature in the inner of the case.
- Attention to the heat sink when you over-clocking. The higher temperature may decrease the life of the device and burned the capacitor.

USER'S NOTICE

COPYRIGHT OF THIS MANUAL BELONGS TO THE MANUFACTURER. NO PART OF THIS MANUAL, INCLUDING THE PRODUCTS AND SOFTWARE DESCRIBED IN IT MAY BE REPRODUCED, TRANSMITTED OR TRANSLATED INTO ANY LANGUAGE IN ANY FORM OR BY ANY MEANS WITHOUT WRITTEN PERMISSION OF THE MANUFACTURER.

THIS MANUAL CONTAINS ALL INFORMATION REQUIRED TO USE THIS MOTHER-BOARD SERIES AND WE DO ASSURE THIS MANUAL MEETS USER'S REQUIREMENT BUT WILL CHANGE, CORRECT ANY TIME WITHOUT NOTICE. MANUFACTURER PROVIDES THIS MANUAL "AS IS" WITHOUT WARRANTY OF ANY KIND, AND WILL NOT BE LIABLE FOR ANY INDIRECT, SPECIAL, INCIDENTAL OR CONSEQUENTIAL DAMAGES (INCLUDING DAMAGES FOR LOSS OF PROFIT, LOSS OF BUSINESS, LOSS OF USE OF DATA, INTERRUPTION OF BUSINESS AND THE LIKE).

PRODUCTS AND CORPORATE NAMES APPEARING IN THIS MANUAL MAY OR MAY NOT BE REGISTERED TRADEMARKS OR COPYRIGHTS OF THEIR RESPECTIVE COMPANIES, AND THEY ARE USED ONLY FOR IDENTIFICATION OR EXPLANATION AND TO THE OWNER'S BENEFIT, WITHOUT INTENT TO INFRINGE.

Manual Revision Information

Reversion	Revision History	Date
1.0	First Edition	June 14, 2017
2.0	Second Edition	August 14, 2017

Item Checklist

- Motherboard
- DVD for motherboard utilities
- User's Manual
- Cable(s)
- I/O Back panel shield

Chapter 1

Introduction of the Motherboard

1-1 Feature of Motherboard

- Intel® LGA1151 Skylake/Kabylake Processor (TDP 65W)
- Intel® Q170 Express Chipset
- Support DDR4-2133, 2 * SO-DIMM slot, up to 32GB memory
- Realtek ALC662VD Audio
- 2 * Intel Giga LAN
- Support 4 * SATA III (6Gb/s), support RAID 0, 1, 5, 10
- Support 2 * DP/HDMI/LVDS, triple displays
- 2 * External COM and 4 * internal COM
- 4 * External USB3.0 & 2 * Internal USB1.1/2.0
- 1 * mini-PCIe slot & 1 * PCIe x4 side-slot
- 1 * SIM Card Holder
- 9 ~ 24V DC IN power
- Support Watchdog Timer Technology
- 1* TPM (onboard option)

1-2 Specification

Spec	Description
Design	● Mini-ITX ; PCB size: 17.0x17.0cm
Chipset	● Intel Q170 Express Chipset
CPU Socket	● Intel® LGA1151 Skylake/Kabylake Processor (TDP 65W) <i>* for detailed CPU support information please visit our website</i>
Memory Slot	● 2* DDR4 SO-DIMM slot ● Support DDR4 2133MHz SO-DIMM up to 32GB ● Support dual channel function
Expansion Slot	● 1* Full-size Mini-PCIe slot ● 1* PCIe x4 side-slot (4 * PCIe x1 combo signals) ● 1* SIM Card Holder
Storage	● 4* SATAIII 6G/s ports with support for RAID 0/1/5/10 mode
Gigabit LAN Chip	● Integrated with 2* Intel Gigabit PCIe LAN chip ● Support Fast Ethernet LAN function of providing 10/100/1000Mbps Ethernet data transfer rate
BIOS	● 128M AMI Flash ROM
Rear I/O	● 1* HDMI ● 2* DisplayPort ● 2* RJ-45 port ● 4* USB3.0 ● 1* Audio (Line-in, Line-out, MIC) ● 2* Serial port (COM1/2: RS232/422/485) ● 1* DC-input
Internal I/O	● 2* USB2.0 ● 1* PS/2 ● 1* LVDS, ● 1* Inverter

-
-
- | | |
|--|---|
| | <ul style="list-style-type: none">● 4* Serial port● 4* SATAIII (6.0Gb/s)● 1* full size Mini PCIe● 1* GPIO header● 1* Chassis Intrusion● 1* Audio header● 1* SMBIS/I2C |
|--|---|

1-3 Product Diagram

For NF697 Series:

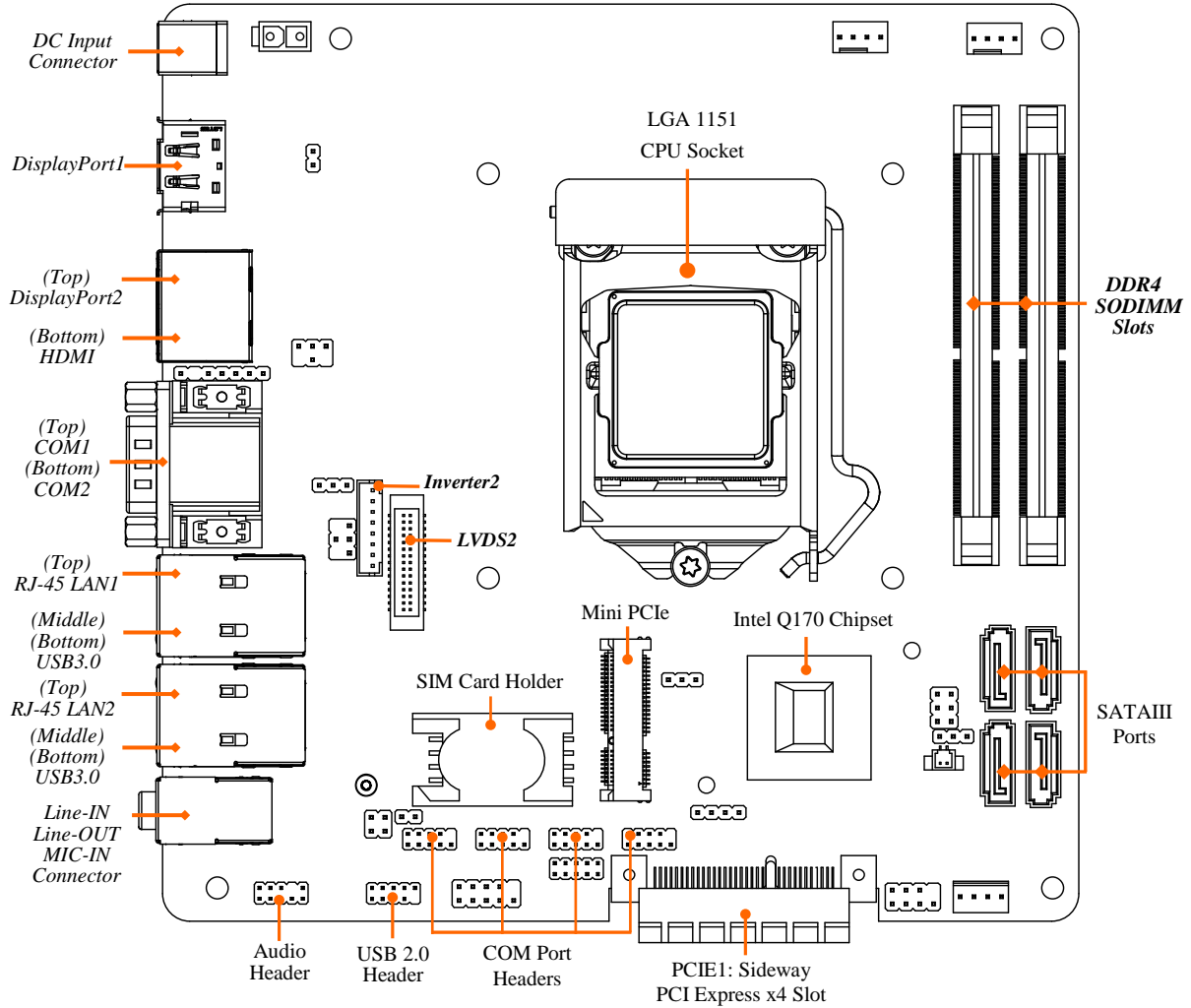

Chapter 2

Hardware Installation

2-1 Location of Internal Jumper and Connector

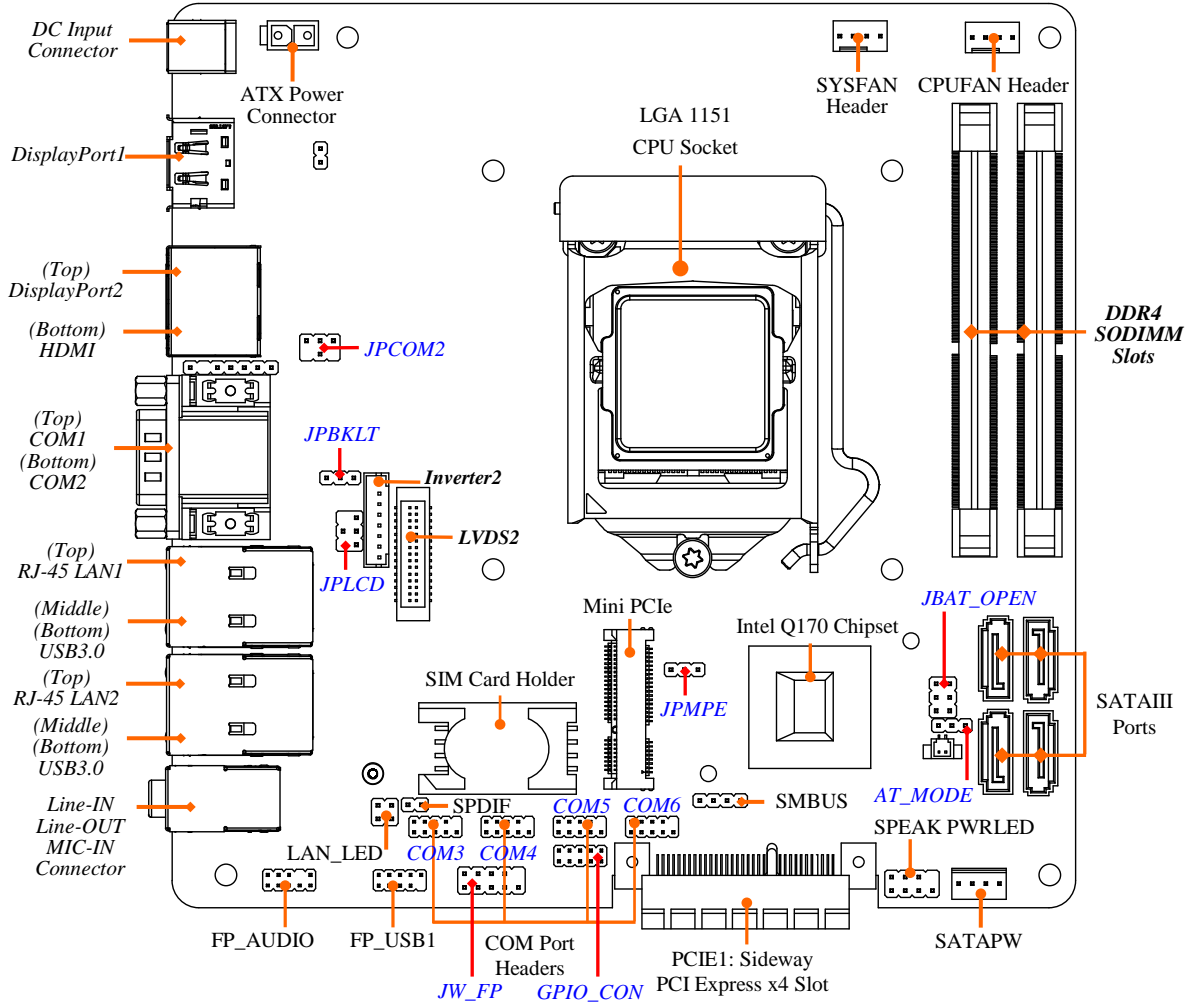

2-2 Internal Jumper and Connector Setting

(1) **JBAT_OPEN (6-pin): Clear CMOS, TXE Override, and Chassis Intrusion Select**

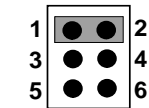
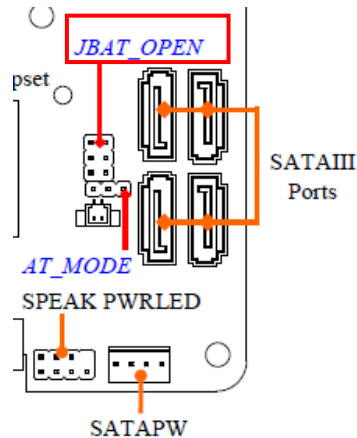

1-2 Closed:
Clear CMOS;

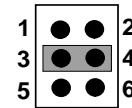

3-4 Closed:
TXE Disable;

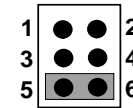

4-6 Closed:
Chassis Intrusion
Header.

(2) **AT_MODE (3-pin): AT/ATX Mode Select**

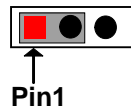
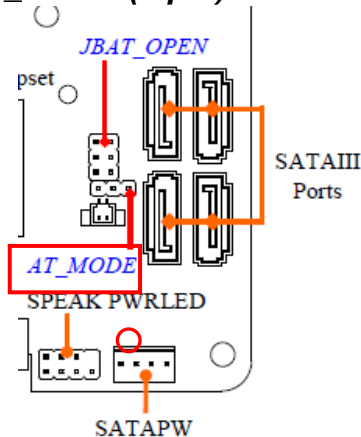

1-2 Closed: ATX Mode(Default);

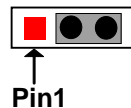

2-3 Closed: AT Mode.

***ATX Mode Selected:** Press power button to power on after power input ready;
AT Mode Selected: Directly power on as power input ready.

(3) GPIO_CON (10-pin): GPIO Header

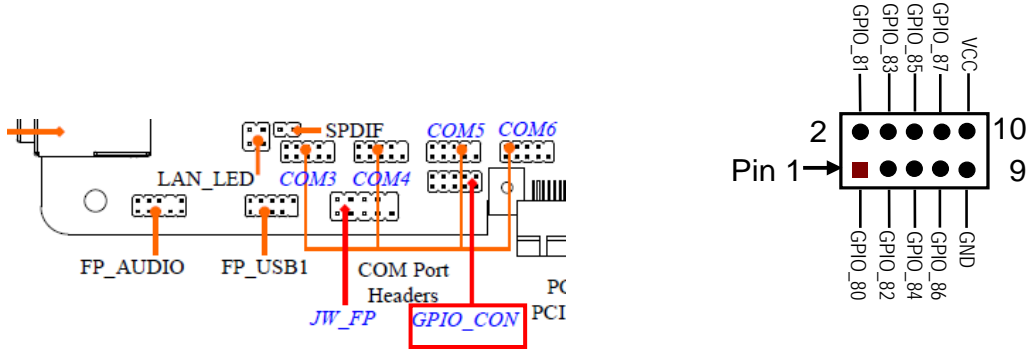

(4) JW_FP (9-pin): Front Panel Header

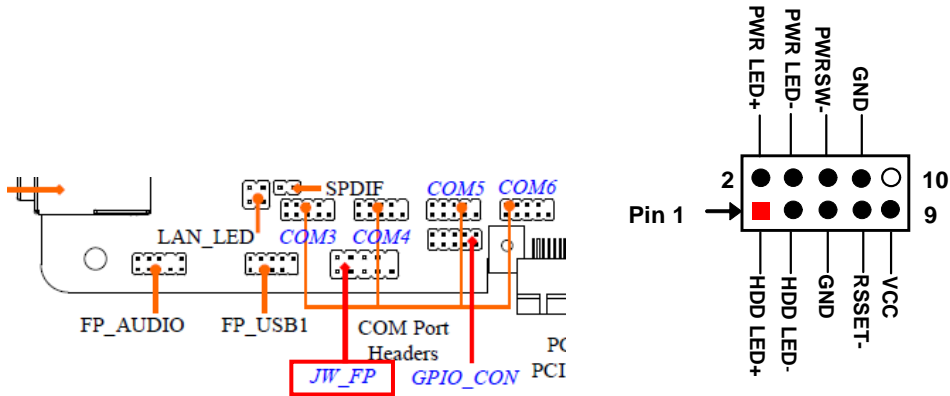

(5) JPMPE (3-pin): Mini PCI-E (MPE) Slot VCC 3.3V/3.3 VSB Select

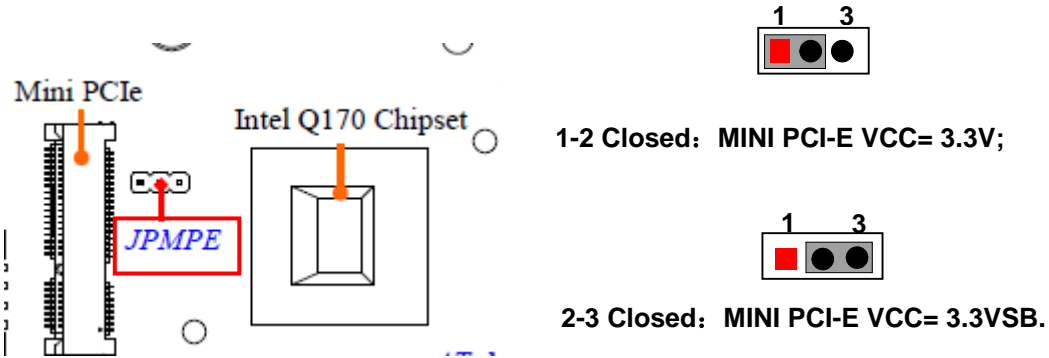

(6) INVERTER2 (8-pin): INVERTER Back Light Select

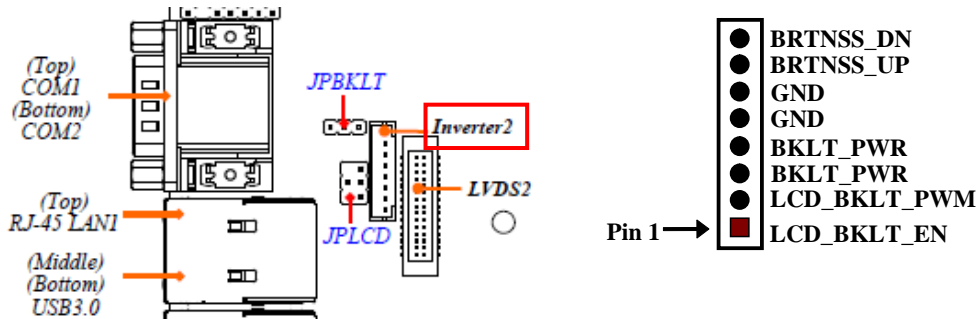

(7) JPLCD(4-pin): LVDS VCC 3.3V/5V/12V Select

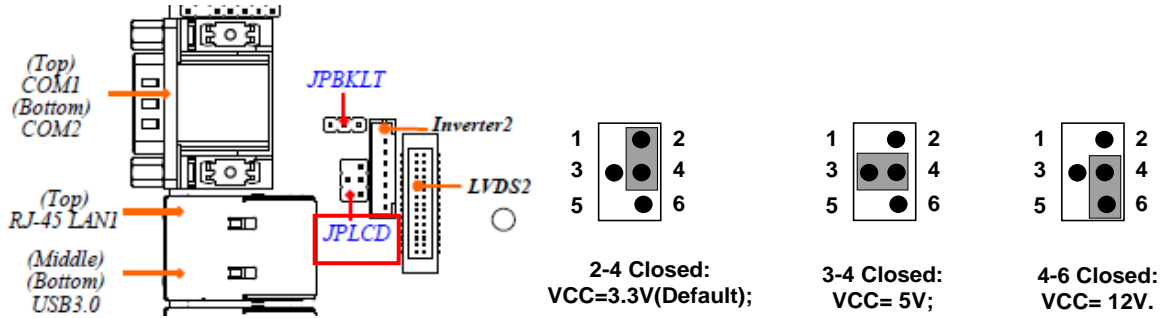

(8) JPBKLT (3-pin): LCD Back Light PWR Select

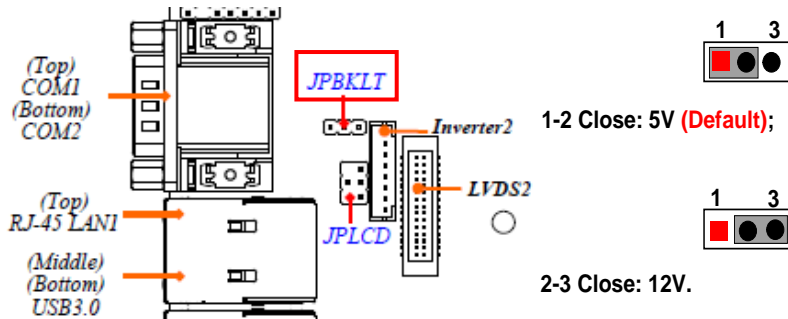



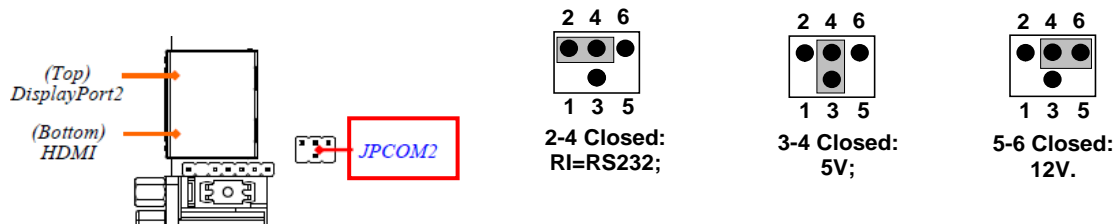

(9) JPCOM2 (4-pin): COM 2 Port RI Select



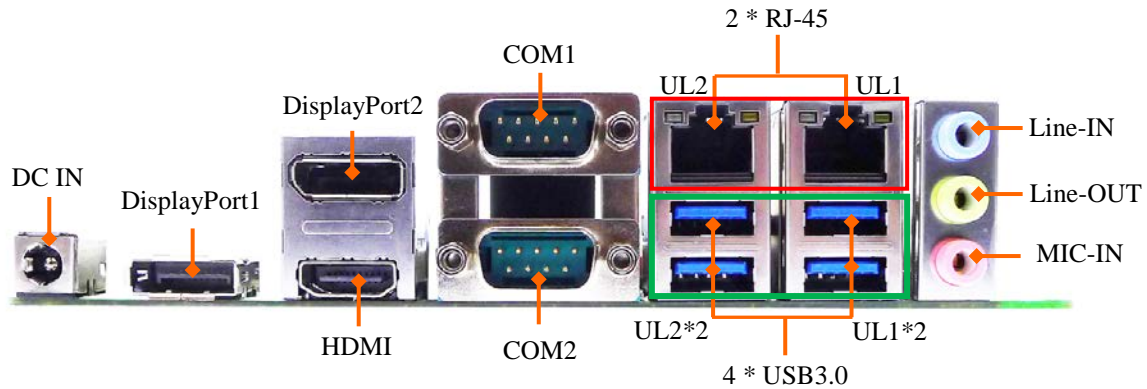

2-2-1 Connectors

(1)Rear IO Connectors

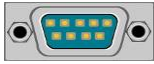

Icon	Name	Function
	DC-in 9-24V Power Connector	For user to connect compatible power adapter to provide power supply for the system.
	DisplayPort	To the system to corresponding display device with compatible DP cable. (Max. resolution Support : 4096*2304 @ 60Hz)
	HDMI Port	To connect display device that support HDMI specification. (Max. resolution Support : 3840*2160 @30Hz)
	Serial Port	Mainly for user to connect external MODEM or other devices that supports Serial Communications Interface. COM1/2: RS232/422/485 Serial Port

	RJ-45 LAN Port	<p>This connector is standard RJ-45 LAN jack for Network connection.</p> <p>UL1: Intel® Ethernet Controller i219</p> <p>UL2: Intel® Ethernet Controller i211</p>
	USB 3.0 Port	<p>To connect USB keyboard, mouse or other devices compatible with USB specification. USB 3.0 ports supports up to 5Gbps data transfer rate.</p>
	Audio Connectors	<p>BLUE : Line-in Connector</p> <p>GREEN : Line-out Connector</p> <p>PINK : MIC Connector</p>

2-2-2 Headers

(1) SATA1/2/3/4 (7-pin): SATA III Port connector

These are high-speed SATAIII port that supports 6 GB/s transfer rate.

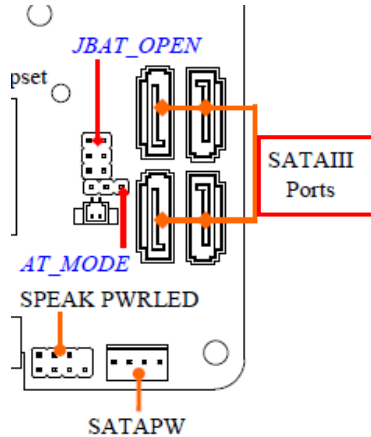

Pin No.	Definition
1	GND
2	TXP
3	TXN
4	GND
5	RXN
6	RXP
7	GND



(2) SATAPW (4-pin): SATA Hard Disk Power-out Connector

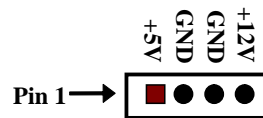
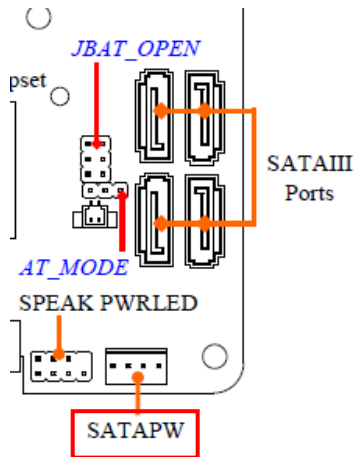

(3) SPK-LED (7-pin): Speaker Power LED Header

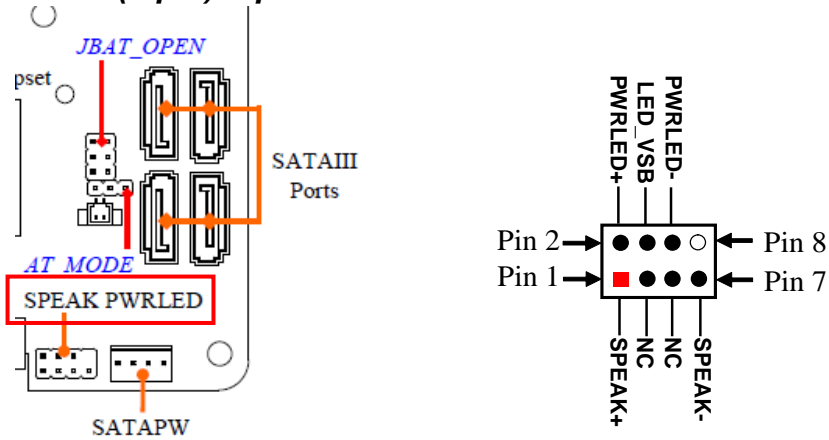

(4) COM3/4/5/6 (9-pin): COM Port Header

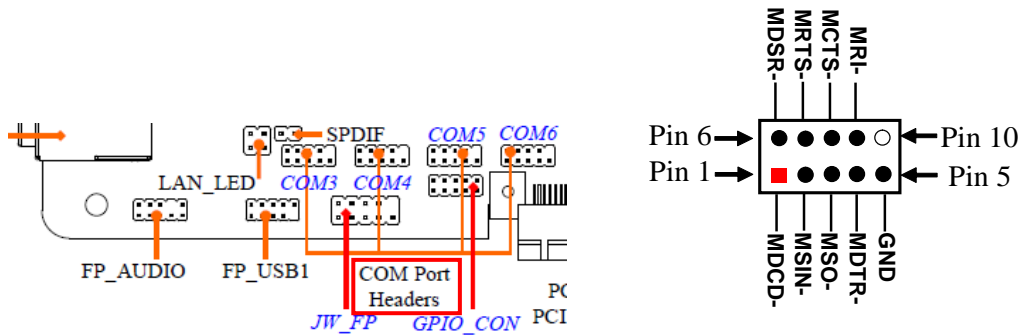

(5) FP_USB1 (9-pin): USB 2.0 Port Header

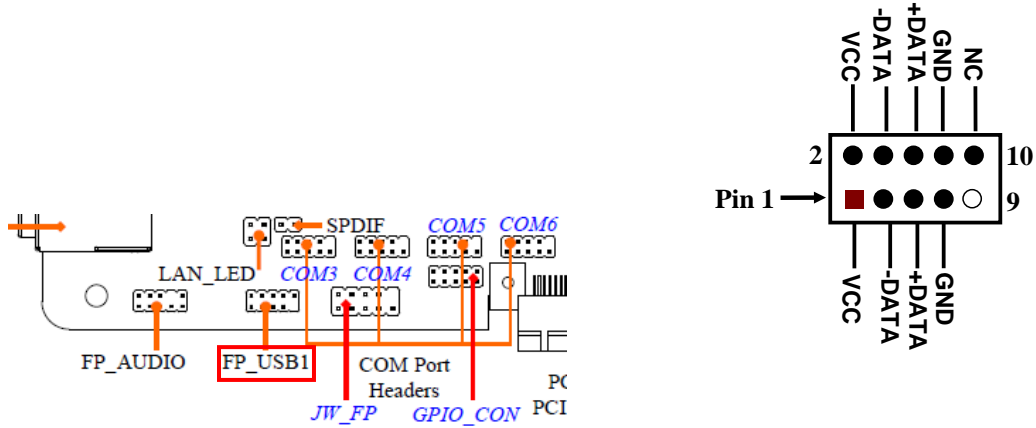

(6) FP_AUDIO (9-pin): Line-In, Line-Out, MIC-In Header

This header connects to Front Panel Line-in, Line-out, MIC-In connector with cable.

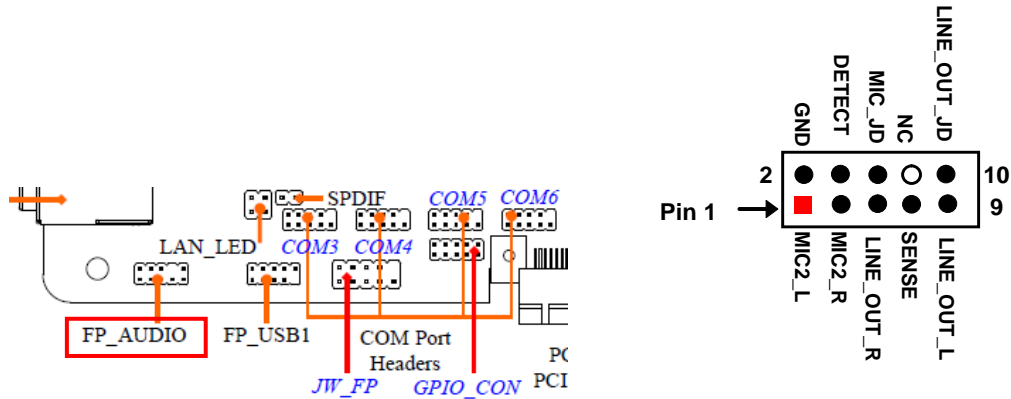

(7) SPDIF(2-pin): HDMI-SPDIF Out header

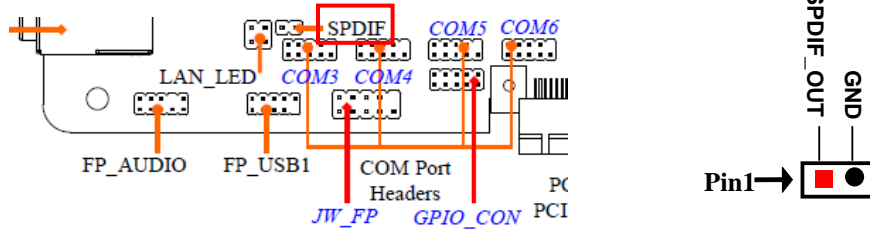

(8) LAN_LED (4-pin): LANLED Header

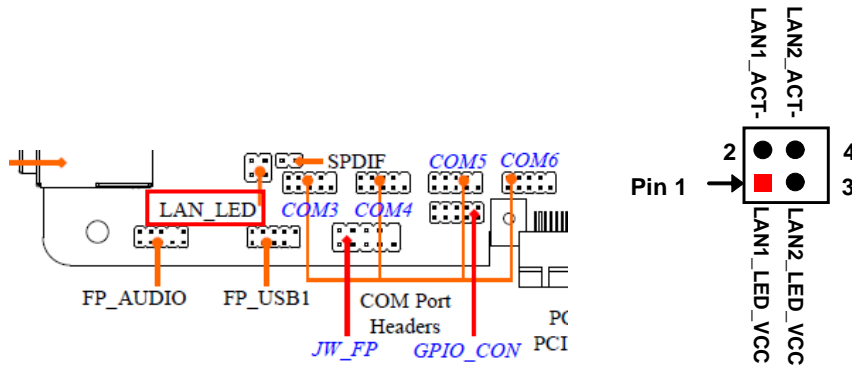

(9) LVDS2 (30-pin): 24-bit dual channel LVDS Header

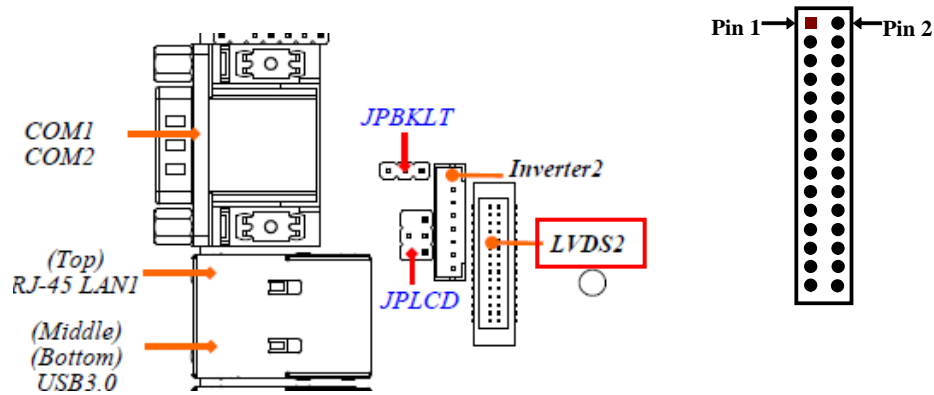

Pin NO.	Pin Define	Pin NO.	Pin Define
Pin 1	LVDSB_DATAN3	Pin 2	LVDSB_DATAP3
Pin 3	LVDS_CLKBN	Pin 4	LVDS_CLKBP
Pin 5	LVDSB_DATAN2	Pin 6	LVDSB_DATAP2
Pin 7	LVDSB_DATAN1	Pin 8	LVDSB_DATAP1
Pin 9	LVDSB_DATAN0	Pin 10	LVDSB_DATAP0
Pin 11	LVDSB_DCC_DAT	Pin 12	LVDSB_DCC_CLK
Pin 13	GND	Pin 14	GND
Pin 15	GND	Pin 16	GND
Pin 17	LVDSA_DATAP3	Pin 18	LVDSA_DATAN3
Pin 19	LVDS_CLKAP	Pin 20	LVDS_CLKAN
Pin 21	LVDSA_DATAP2	Pin 22	LVDSA_DATAN2
Pin 23	LVDSA_DATAP1	Pin 24	LVDSA_DATAN1
Pin 25	LVDSA_DATAP0	Pin 26	LVDSA_DATAN0
Pin 27	LCD_VCC	Pin 28	LCD_VCC
Pin 29	LCD_VCC	Pin 30	LCD_VCC

(10) **ATXPWR(2-pin): DC-IN Power 9-24V Select**

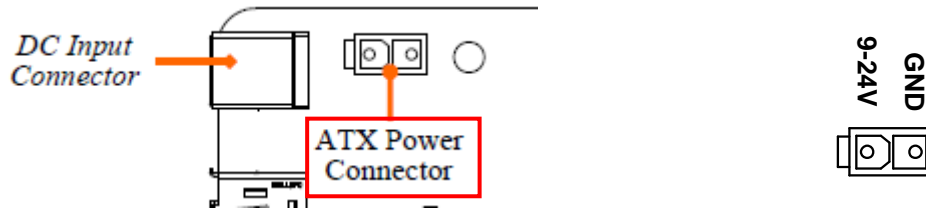

(11) **SYSFAN: System Fan Header**

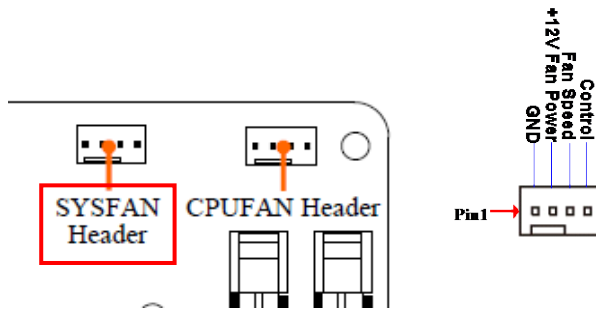

(12) **CPUFAN: CPU Fan Header**

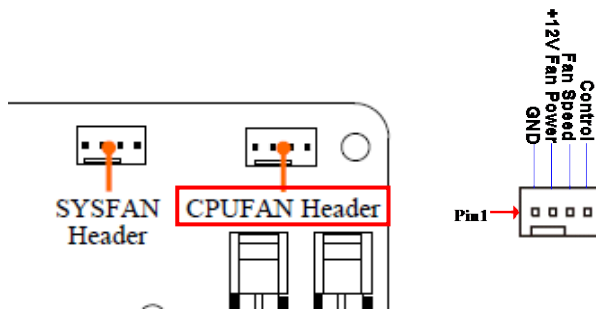

Chapter 3

Introducing BIOS

Notice! The BIOS options in this manual are for reference only. Different configurations may lead to difference in BIOS screen and BIOS screens in manuals are usually the first BIOS version when the board is released and may be different from your purchased motherboard. Users are welcome to download the latest BIOS version form our official website.

The BIOS is a program located on a Flash Memory on the motherboard. This program is a bridge between motherboard and operating system. When you start the computer, the BIOS program will gain control. The BIOS first operates an auto-diagnostic test called POST (power on self test) for all the necessary hardware, it detects the entire hardware device and configures the parameters of the hardware synchronization. Only when these tasks are completed done it gives up control of the computer to operating system (OS). Since the BIOS is the only channel for hardware and software to communicate, it is the key factor for system stability, and in ensuring that your system performance as its best.

3-1 Entering Setup

Power on the computer and by pressing immediately allows you to enter Setup. If the message disappears before your respond and you still wish to enter Setup, restart the system to try again by turning it OFF then ON or pressing the “RESET” button on the system case. You may also restart by simultaneously pressing <Ctrl>, <Alt> and <Delete> keys. If you do not press the keys at the correct time and the system does not boot, an error message will be displayed and you will again be asked to

Press **** to enter Setup

3-2 BIOS Menu Screen

The following diagram show a general BIOS menu screen:

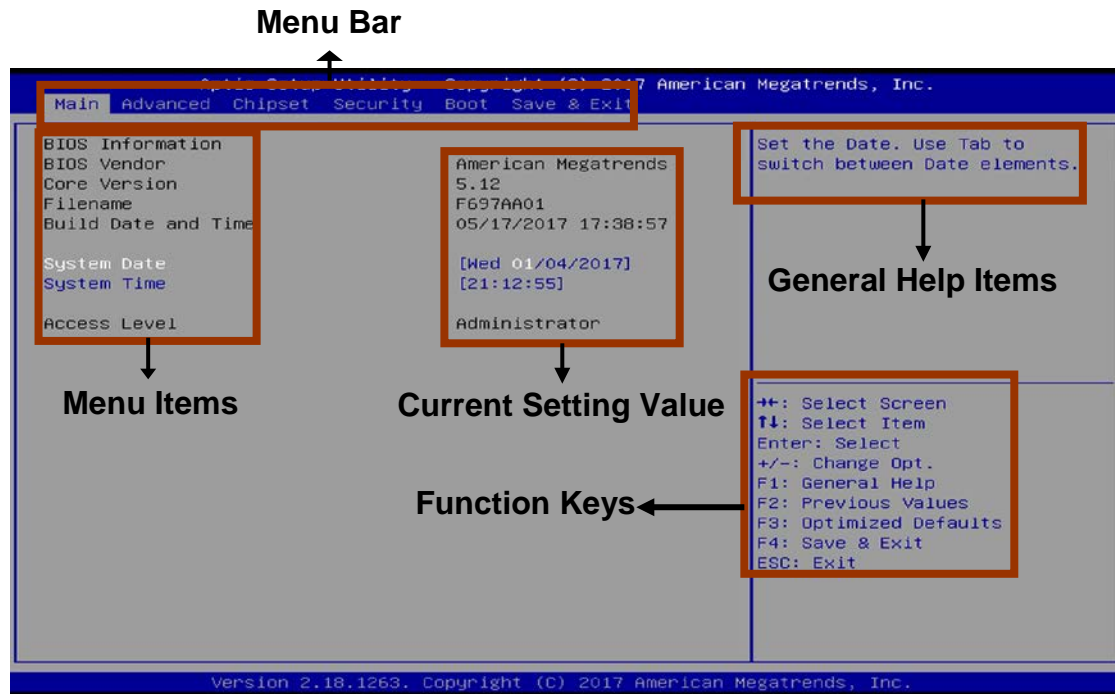

BIOS Menu Screen

3-3 Function Keys

In the above BIOS Setup main menu of, you can see several options. We will explain these options step by step in the following pages of this chapter, but let us first see a short description of the function keys you may use here:

- Press ←→ (left, right) to select screen;
- Press ↑↓ (up, down) to choose, in the main menu, the option you want to confirm or to modify.
- Press <Enter> to select.

-
- Press <+>/<-> keys when you want to modify the BIOS parameters for the active option.
 - [F1]: General help.
 - [F2]: Previous values.
 - [F3]: Optimized defaults.
 - [F4]: Save & Exit.
 - Press <Esc> to exit from BIOS Setup.

3-4 Getting Help

Main Menu

The on-line description of the highlighted setup function is displayed at the top right corner the screen.

Status Page Setup Menu/Option Page Setup Menu

Press **[F1]** to pop up a small help window that describes the appropriate keys to use and the possible selections for the highlighted item. To exit the Help Window, press <Esc>.

3-5 Menu Bars

There are six menu bars on top of BIOS screen:

Main	To change system basic configuration
Advanced	To change system advanced configuration
Chipset	To change chipset configuration
Security	Password settings
Boot	To change boot settings
Save & Exit	Save setting, loading and exit options.

User can press the right or left arrow key on the keyboard to switch from menu bar. The selected one is highlighted.

3-6 Main Menu

Main menu screen includes some basic system information. Highlight the item and then use the <+> or <-> and numerical keyboard keys to select the value you want in each item.

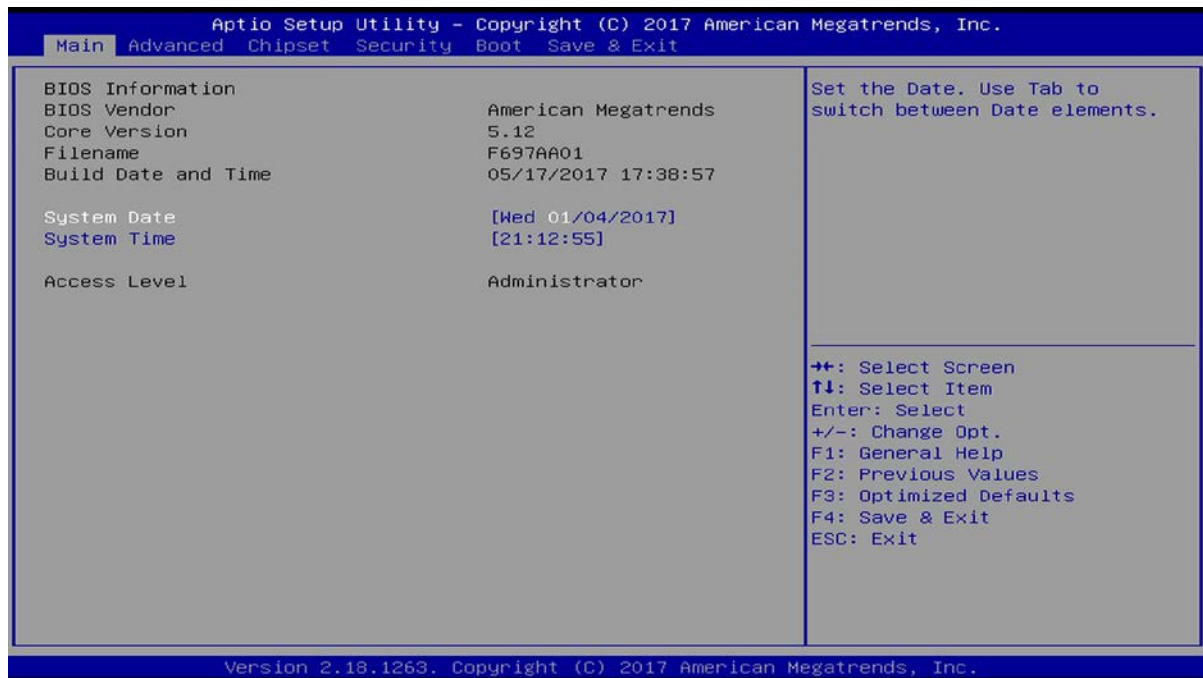

System Date

Set the date. Please use [Tab] to switch between data elements.

System Time

Set the time. Please use [Tab] to switch between time elements.

3-7 Advanced Menu

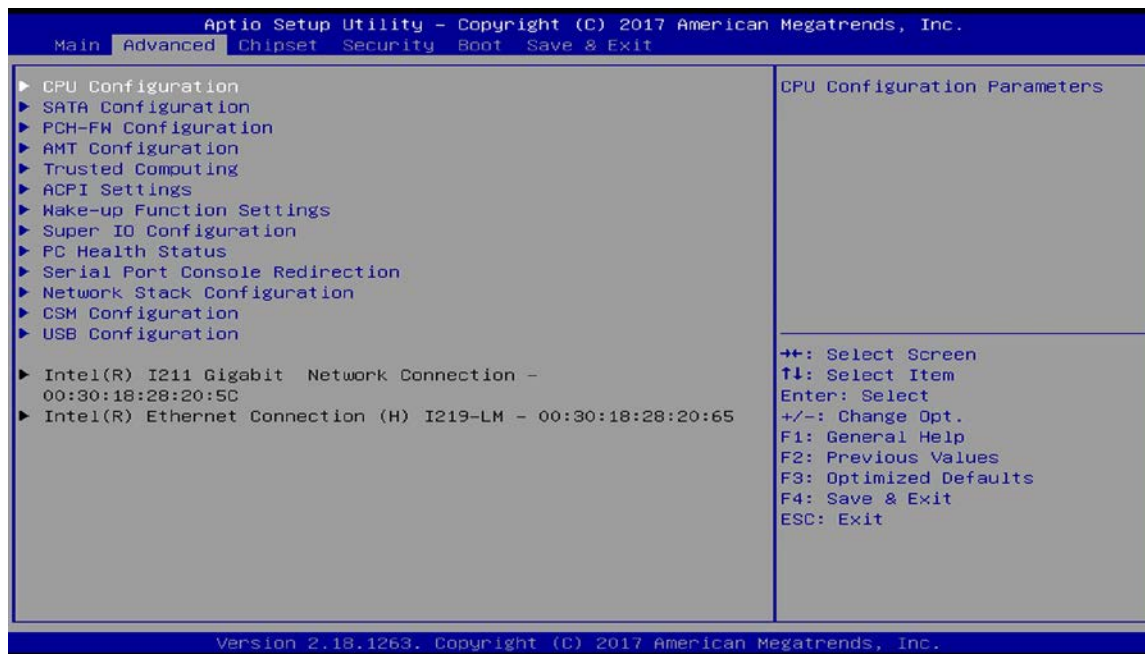

▶ **CPU Configuration**
Hyper-Threading

The optional settings: [Disabled]; [Enabled].

When set as [Disabled] only one thread per enabled core is enabled.

[Enabled]: for Windows and Linux (OS optimized for Hyper-Threading Technology).

[Disabled]: for other OS (OS optimized not for Hyper-Threading Technology).

Intel Virtualization Technology

When enabled, a VMM can utilize the additional hardware capabilities provided by Vanderpool Technology.

The optional settings: [Disabled]; [Enabled].

Hardware Prefetcher

Use this item to turn on/off the MLC streamer prefetcher.

The optional settings: [Disabled]; [Enabled].

Adjacent Cache Line Prefetch

Use this item to turn on/off prefetching of adjacent cache lines.

The optional settings: [Disabled]; [Enabled].

Intel(R) SpeedStep(tm)

This item allows more than two frequency ranges to be supported.

The optional settings: [Disabled]; [Enabled].

CPU C states

Use this item to Enable/disable CPU Power Management, also allows CPU to go to C states when it's not 100% utilized.

The optional settings: [Disabled]; [Enabled].

Package C State Limit

Use this item to select Maximum Package C State Limit Setting. CPU Default: Leaves to Factory default value. Auto: Initializes to deepest available Package C State Limit.

The optional settings: [C0/C1]; [C2]; [C3]; [C6]; [C7]; [C7S]; [C8]; [C9]; [C10]; [CPU Default]; [Auto];.

► **SATA Configuration**

Use this item to select SATA Device Options Settings.

SATA Controller(s)

Use this item to enable or disable SATA Device.

The optional settings: [Enabled]; [Disabled].

SATA Mode Selection

This item determines how SATA controller(s) operate.

The optional settings: [AHCI]; [RAID].

SATA Port

Use this item to enable or disable SATA Port.

The optional settings: [Disabled]; [Enabled].

Hot Plug

Use this item to designate SATA port as Hot Pluggable.

The optional settings: [Disabled]; [Enabled].

► **PCH-FW Configuration**

Press [Enter] to configure Management Engine Technology Parameters.

TPM Device Selection

Use this item to select TPM device as PTT or dTPM. PTT - Enables PTT in SkuMgr dTPM 1.2 – Disables PTT in SkuMgr Warning! PTT/dTPM will be disabled and all data saved on it will be lost.

The optional settings are: [dTPM]; [PTT].

▶ **Firmware Update Configuration**

Use this item to configure Management Engine Technology parameters.

Press [Enter] to make settings for the following sub-items:

Me FW Image Re-Flash

Use this item to enable or disable me FW Image Re-Flash function.

The optional settings: [Disabled]; [Enabled].

▶ **AMT Configuration**

Use this item to configure Intel Active Management Technology parameters.

Press [Enter] to make settings for the following sub-items:

Intel AMT

Use this item to enable or disable Intel Active Management Technology BIOS extension.

Hide Un-Configure ME Confirmation Prompt

Use this function to enable or disable Hide Un-Configure ME without password Configuration Prompt function.

MEBx Debug Message Output

Use this function to enable or disable MEBx Debug Message Output function.

Un-Configure ME

Use this function to enable or disable Un-Configure ME without password function.

ASF

Use this item to enable or disable Alert Specification Format.

Activate Remote Assistance Process

Use this item to enable or disable Trigger CIRA boot function.

USB Configure

Use this item to enable or disable USB configure function.

PET Progress

Use this item to enable or disable PET events progress to receive PET events or not.

AMT CIRA Timeout

OEM defined timeout for MPS connection to be established. 0 – use the default time value of 60 seconds. 255 – MEBx waits until the connection succeeds.

WatchDog

Use this item to enable or disable WatchDog Timer. When set as [Enabled], the following sub-items shall appear:

OS Timer

Use this item to set OS watch dog timer.

BIOS Timer

Use this item to set BIOS watch dog timer.

▶ **Trusted Computing**

Press [Enter] to enable or disable ‘**Security Device Support**’.

Security Device Support

Use this item to enable or disable BIOS support for security device. O.S. will not show security device. TGG EFI protocol and INT1A interface will not be available. The optional settings: [Disabled]; [Enabled].

When set as **[Enabled], user can make further settings in the following items:*

TPM State

Use this item to enable or disable security device. Your computer will reboot during restart to change state of device.

The optional settings: [Disabled]; [Enabled].

Pending Operation

Use this item to schedule an operation for the security device. Your computer will reboot during restart to change state of device.

The optional settings: [None]; [TPM Clear].

▶ **ACPI Settings**

Press [Enter] to make settings for the following sub-items:

ACPI Sleep State

Use this item to select the highest ACPI sleep state the system will enter when the suspend button is pressed.

The optional settings are: [Suspend Disabled]; [S3 (Suspend to RAM)].

► **Wake-up Function Settings**

Press [Enter] to make settings for the following sub-items:

Wake-up System with Fixed Time

Use this item to enable or disable system wake on alarm event.

The optional settings: [Disabled]; [Enabled].

When set as [Enabled], system will wake on the hour/min/sec specified.

Wake-up System with Dynamic Time

Use this item to enable or disable system wake on alarm event.

System will wake on the current time + Increase minutes.

The optional settings: [Disabled]; [Enabled].

When set as [Enabled], system will wake on the current time + increased minute(s).

PS2 KB/MS Wake-up

The optional settings: [Disabled]; [Enabled].

Use this item to enable or disable PS2 KB/MS wake-up from S3/S4/S5.

**This function is supported when 'ERP Support' is set as [Disabled].*

USB S3/S4 Wake-up

The optional settings: [Disabled]; [Enabled].

Use this item to enable or disable USB S3/S4 wake-up.

**This function is supported when 'ERP Support' is set as [Disabled].*

USB S5 Power

Use this item to enable or disable USB power after system shutdown.

**This function is supported when 'ERP Support' is set as [Disabled].*

Ring Wake-up

Use this item to enable or disable Ring Wake-up..

The optional settings: [Disabled]; [Enabled].

► **Super IO Configuration**

Press [Enter] to make settings for the following sub-items:

ERP Support

The optional settings: [Disabled]; [Auto].

This item should be set as [**Disabled**] if you wish to have all active wake-up functions.

► **Serial Port 1~6 Configuration**

Press [Enter] to make settings for the following items:

Serial Port

Use this item to enable or disable serial port (COM).

Change Settings

Use this item to select an optimal setting for super IO device.

Transmission Mode Select

Use this item to select serial port mode.

The optional settings: [RS422]; [RS232]; [RS485].

Mode Speed Select

Use this item to select RS232/RS422/RS485 speed.

The optional settings: [RS232/RS422/RS485=250Kbps]; [RS232=1Mbps, RS422/RS485=10Mbps].

Serial Port FIFO Mode

The optional settings are: [16-Byte FIFO]; [32-Byte FIFO]; [64-Byte FIFO]; [128-Byte FIFO].

WatchDog Reset Timer

Use this item to enable or disable WDT reset function. When set as [Enabled], the following sub-items shall appear:

WatchDog Reset Timer Value

User can set a value in the range of [4] to [255].

WatchDog Reset Timer Unit

The optional settings are: [Sec.]; [Min.].

WatchDog Wake-up Timer in ERP

This item support WDT wake-up while ‘**ERP Support**’ is set as [Auto].

The optional settings: [Disabled]; [Enabled].

When set as [Enabled], the following sub-items shall appear:

WatchDog Timer Value in ERP

User can select a value in the range of [10] to [4095] seconds when ‘**WatchDog Reset Timer Unit in ERP**’ set as [Sec]; or in the range of [1] to [4095] minutes

when '**WatchDog Reset Timer Unit in ERP**' set as [Min].

WatchDog Timer Unit in ERP

The optional settings are: [Sec.]; [Min.].

ATX Power Emulate AT Power

This item support Emulate AT power function, MB power On/Off control by power supply. Use needs to select 'AT or ATX Mode' on MB jumper at first (refer to **Page 8**, AT_MODE jumper for ATX Mode & AT Mode Select).

Case Open Detect

Use this item to detect case has already open or not, show message in POST.

The optional settings: [Disabled]; [Enabled].

PS2 KB/MS Connect

Use this item to select PS2 connect primary device.

The optional settings are: [Keyboard First]; [Mouse First].

▶ **PC Health Status**

Press [Enter] to view current hardware health status, make further settings in '**SmartFAN Configuration**' and set value in '**Shutdown Temperature**'.

SmartFAN Configuration

Press [Enter] to make settings for SmartFan Configuration:

CPUFAN Smart Mode

The optional settings are: [Disabled]; [Enabled].

When set as [Enabled], the following sub-items shall appear:

CPUFAN Full-Speed Temperature

Use this item to set CPUFAN full speed temperature. Fan will run at full speed when above this pre-set temperature.

CPUFAN Full-Speed Duty

Use this item to set CPUFAN full-speed duty. Fan will run at full speed when above this pre-set duty.

CPUFAN Idle-Speed Temperature

Use this item to set CPUFAN idle speed temperature. Fan will run at idle speed when below this pre-set temperature.

CPUFAN Idle-Speed Duty

Use this item to set CPUFAN idle speed duty. Fan will run at idle speed when below this pre-set duty.

SYSFAN1 Smart Mode

The optional settings are: [Disabled]; [Enabled].

When set as [Enabled], the following sub-items shall appear:

SYSFAN1 Full-Speed Temperature

Use this item to set SYSFAN1 full speed temperature. Fan will run at full speed when above this pre-set temperature.

SYSFAN1 Full-Speed Duty

Use this item to set SYSFAN1 full-speed duty. Fan will run at full speed when above this pre-set duty.

SYSFAN1 Idle-Speed Temperature

Use this item to set SYSFAN1 idle speed temperature. Fan will run at idle speed when below this pre-set temperature.

SYSFAN1 Idle-Speed Duty

Use this item to set SYSFAN1 idle speed duty. Fan will run at idle speed when below this pre-set duty.

Shutdown Temperature

Use this item to select system shutdown temperature.

The optional settings are: [Disabled]; [70°C/156°F]; [75°C/164°F]; [80°C/172°F]; [85°C/180°F]; [90°C/188°F].

▶ **Serial Port Console Redirection**

Press [Enter] to make settings for the following sub-items:

COM1

Console Redirection

Use this item to enable or disable COM1 Console Redirection.

The optional settings are: [Disabled]; [Enabled].

*When set as [Enabled], user can make further settings in the ‘**Console Redirection Settings**’ screen:*

▶ **Console Redirection Settings**

The settings specify how the host computer and the remote computer (which the

user is using) will exchange data. Both computers should have the same or compatible settings.

Press [Enter] to make settings for the following sub-items.

Terminal Type

The optional settings are: [VT100]; [VT100+]; [VT-UTF8]; [ANSI].

Bits per second

The optional settings are: [9600]; [19200]; [38400]; [57600]; [115200].

Data Bits

The optional settings are: [7]; [8].

Parity

The optional settings are: [None]; [Even]; [Odd]; [Mark]; [Space].

Stop Bits

The optional settings are: [1]; [2].

Flow Control

The optional settings are: [None]; [Hardware RTS/CTS].

VT-UTF8 Combo Key Support

The optional settings are: [Disabled]; [Enabled].

Recorder Mode

The optional settings are: [Disabled]; [Enabled].

Resolution 100x31

The optional settings are:[Disabled]; [Enabled].

Legacy OS Redirection Resolution

The optional settings are: [80x24]; [80x25].

Putty Keypad

The optional settings are: [VT100]; [LINUX]; [XTERMR6]; [SCO]; [ESCN]; [VT400].

Redirection After BIOS POST

The optional settings are: [Always Enable]; [BootLoader].

Serial Port for Out-of-Band Management/

Windows Emergency Management Services (EMS)

Console Redirection

The optional settings: [Disabled]; [Enabled].

When set as [Enabled], user can make further settings in '**Console Redirection Settings**' screen:

◆ **Console Redirection Settings**

The settings specify how the host computer and the remote computer (which the user is using) will exchange data. Both computers should have the same or compatible settings.

Press [Enter] to make settings for the following sub-items.

Out-of-Band Mgmt Port

The optional settings are: [COM1]; [COM1(Pci Bus0, Dev0, Func0) (Disabled)].

Terminal Type

The optional settings are: [VT100]; [VT100+]; [VT-UTF8]; [ANSI].

Bits per second

The optional settings are: [9600]; [19200]; [57600]; [115200].

Flow Control

The optional settings are: [None]; [Hardware RTS/CTS]; [Software Xon/Xoff].

Data Bits

The default setting is: [8].

**This item may or may not show up, depending on different configuration.*

Parity

The default setting is: [None].

**This item may or may not show up, depending on different configuration.*

Stop Bits

The default setting is: [1].

**This item may or may not show up, depending on different configuration.*

▶ **Network Stack Configuration**

Press [Enter] to go to '**Network Stack**' screen to make further settings.

Network Stack

Use this item to enable or disable UEFI Network Stack.

The optional settings: [Disabled]; [Enabled].

When set as [Enabled], the following sub-items shall appear:

Ipv4 PXE Support

The optional settings are: [Disabled]; [Enabled].

Use this item to enable Ipv4 PXE Boot Support. When set as [Disabled], Ipv4 boot option will not be created.

Ipv4 HTTP Support

The optional settings are: [Disabled]; [Enabled].

Use this item to enable Ipv4 HTTP Boot Support. When set as [Disabled], Ipv4 HTTP boot option will not be created.

Ipv6 PXE Support

The optional settings are: [Disabled]; [Enabled].

Use this item to enable Ipv6 PXE Boot Support. When set as [Disabled], Ipv6 boot optional will not be created.

Ipv6 HTTP Support

The optional settings are: [Disabled]; [Enabled].

Use this item to enable Ipv6 HTTP Boot Support. When set as [Disabled], Ipv6 HTTP boot option will not be created.

PXE boot wait time

Use this item to set wait time to press [ESC] key to abort the PXE boot.

Media Detect Count

Use this item to set number of times presence of media will be checked.

▶ **CSM Configuration**

Press [Enter] to make settings for the following sub-items:

Option ROM execution

Network

This option controls the execution of UEFI and Legacy PXE OpROM.

The optional settings are: [Do not launch]; [Legacy].

Storage

This option controls the execution of UEFI and Legacy Storage OpROM.

The optional settings are: [Do not launch]; [UEFI]; [Legacy].

Other PCI devices

This item is for PCI devices other than Network, Mass storage or video defines which OpROM to launch.

The optional settings are: [Do not launch]; [UEFI]; [Legacy].

▶ **USB Configuration**

Press [Enter] to make settings for the following sub-items:

Legacy USB Support

The optional settings are: [Enabled]; [Disabled]; [Auto].

[Enabled]: To enable legacy USB support.

[Disabled]: to keep USB devices available only for EFI specification,

[Auto]: To disable legacy support if no USB devices are connected.

XHCI Hand-off

This is a workaround for OSeS without XHCI hand-off support. The XHCI ownership change should be claimed by XHCI driver.

The optional settings are: [Enabled]; [Disabled].

USB Mass Storage Driver Support

The optional settings are: [Disabled]; [Enabled].

USB hardware delay and time-out

USB Transfer time-out

Use this item to set the time-out value for control, bulk, and interrupt transfers.

The optional settings are: [1 sec]; [5 sec]; [10 sec]; [20 sec].

Device reset time-out

Use this item to set USB mass storage device start unit command time-out.

The optional settings are: [10 sec]; [20 sec]; [30 sec]; [40 sec].

Device power-up delay

Use this item to set maximum time the device will take before it properly reports itself to the host controller. 'Auto' uses default value: for a root port it is 100 ms, for a hub port the delay is taken from hub descriptor. The optional settings: [Auto]; [Manual]. Select [Manual] you can set value for the following sub-item: **Device Power-up delay in seconds**, the delay range in from 1 to 40 seconds, in one second increments.

- ▶ **Intel(R) I211 Gigabit Network Connection- XX:XX:XX:XX:XX / Intel(R) Ethernet Connection (H) I219-LM- XX:XX:XX:XX:XX**

This item shows current network brief information.

Note: Use should slide down to the bottom of the screen to view information for '**Intel(R) Ethernet Connection (H) I219-LM- XX:XX:XX:XX:XX**'

3-8 Chipset Menu

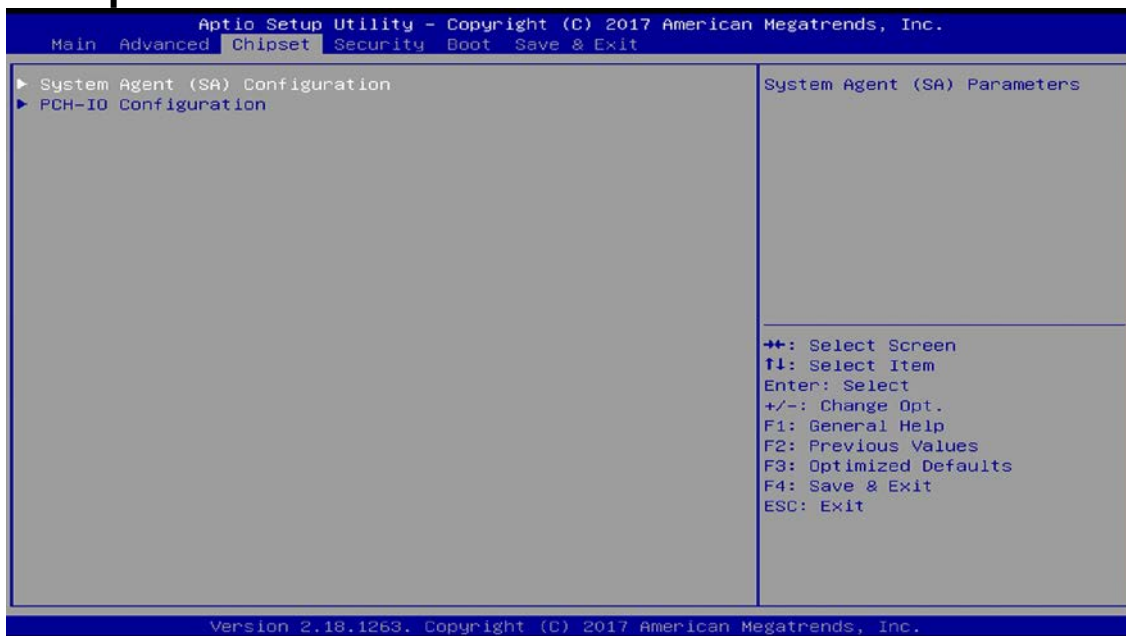

▶ **System Agent (SA) Configuration**

Press [Enter] to make settings for the following sub-items:

VT-d

The optional settings are: [Disabled]; [Enabled].

▶ **Graphics Configuration**

Press [Enter] to make further settings for Graphics Configuration.

GTT Size

The optional settings are: [2MB]; [4MB]; [8MB].

Aperture Size

The optional settings are: [128MB]; [256MB]; [512MB]; [1024MB].

DVMT Pre-Allocated

Use this item to select DVMT 5.0 pre-allocated (fixed) graphics memory size used by the internal graphics device.

The optional settings are: [32M]; [64M]; [96M]; [128M]; [160M]; [192M]; [224M];

[256M]; [288M]; [320M]; [352M]; [384M]; [416M]; [448M]; [480M]; [512M]; [1024M]; [1536M]; [2048M]; [4M]; [8M]; [12M]; [16M]; [20M]; [24M]; [28M]; [32M/F7]; [36M]; [40M]; [44M]; [48M]; [52M]; [56M]; [60M].

DVMT Total Gfx Mem

Use this item to select DVMT 5.0 total graphics memory size used by the internal graphics device.

The optional settings are: [128M]; [256M]; [MAX].

Primary IGFX Boot Display

Use this item to select Video Device which will be activated during POST. This has no effect if external graphics present. Secondary boot display selection will appear based on selection. BGA modes will be supported only on primary display.

The optional settings are: [VBIOS Default]; [HDMI]; [DP1]; [DP2]; [LVDS].

** Note: When set as [HDMI], [DP1], [eDP2] or [LVDS], user can make further settings in 'Second IGFX Boot Display' .*

Second IGFX Boot Display

Use this item to select second IGFX boot device..

The optional settings are: [Disabled]; [HDMI]; [DP1]; [DP2].

Active LVDS

Use this item to select Active LFP Configuration. [No LVDS]: VBIOS does not enable LVDS. [Int-LVDS]: VBIOS enables LVDS driver by Integrated encoder. [SDVO LVDS]: VBIOS enables LVDS driver by SDVO encoder. [eDP Port-A]: LFP Driven by Int-DisplayPort encoder from Port-A.

The optional settings are: [Disabled]; [Enabled].

When set as [Enabled], the following sub-items shall appear:

Backlight Control

Use this item to select Back Light Control setting.

The optional settings are: [PWM inverted]; [PWM Normal].

Panel Type

Use this item to select Panel Type.

The optional settings are: [800x480 18bit Single]; [800x600 18bit Single]; [800x600 24bit Single]; [1024x600 18bit Single]; [1024x768 18bit Single]; [1024x768 24bit Single]; [1280x768 24bit Single]; [1280x800 18bit Single]; [1280x800 24bit Single]; [1366x768 18bit Single]; [1366x768 24bit Single];

[1440x900 18bit Dual]; [1440x900 24bit Dual]; [1280x1024 24bit Dual];
[1680x1050 24bit Dual]; [1920x1080 24bit Dual].

LVDS FW Write Protect

Use this item to select LVDS FW Update/Protect.

The optional settings are: [Disabled]; [Enabled].

▶ **Memory Configuration**

Press [Enter] to view brief information for the working memory module.

▶ **PCH-IO Configuration**

Press [Enter] to make settings for the following sub-items:

USB Controller

The optional settings are: [Disabled]; [Enabled].

HD Audio

The optional settings are: [Disabled]; [Enabled]; [Auto].

PCIE Slot

The optional settings are: [Enabled]; [Disabled].

Onboard Lan1 Controller

The optional settings are: [Enabled]; [Disabled].

When set as [Enabled], the following sub-items shall appear:

Wake on LAN

The optional settings are: [Enabled]; [Disabled].

Onboard Lan2 Controller

The optional settings are: [Enabled]; [Disabled].

MPE Slot

Use this item to enable or disable the PCI Express root port.

The optional settings are: [Disabled]; [Enabled].

Speed

The optional settings are: [Auto]; [Gen1]; [Gen2]; [Gen3].

System State after Power Failure

Use this item to specify what state to go to when power re-applied after a power failure (G3 state).

The optional settings are: [Always On]; [Always Off]; [Former State].

3-9 Security Menu

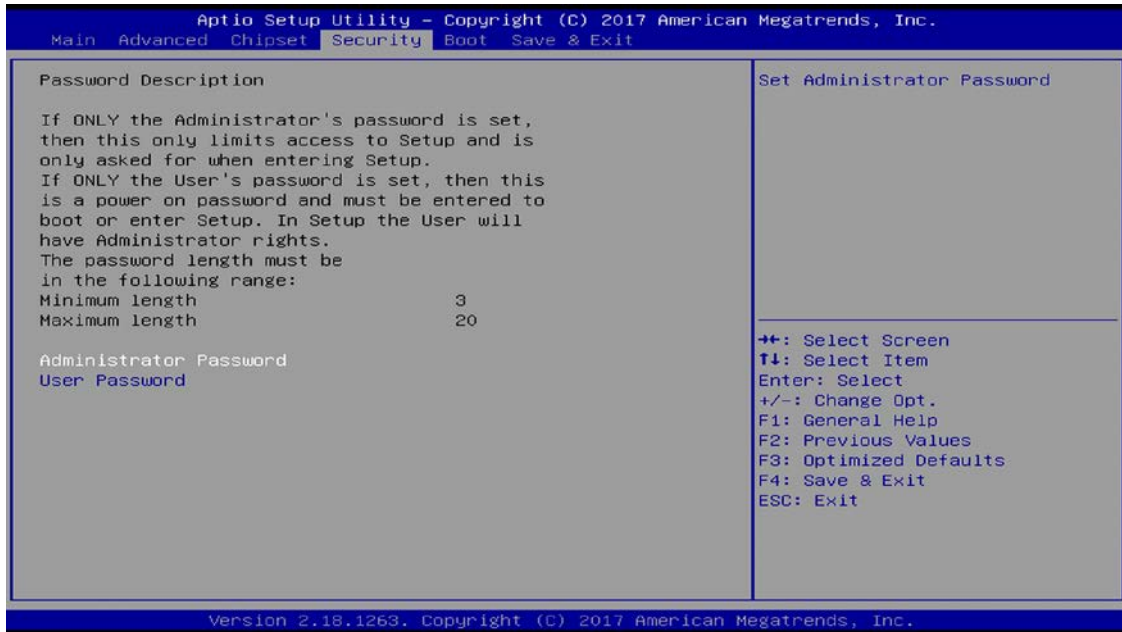

Security menu allow users to change administrator password and user password settings.

Administrator Password

Press [Enter] to create new administrator password. Press again to confirm the new administrator password.

User Password

Press [Enter] to create new user password. Press again to confirm the new user password.

3-10 Boot Menu



Boot Configuration

Setup Prompt Timeout

Use this item to set number of seconds to wait for setup activation key.

Bootup Numlock State

Use this item to select keyboard numlock state.

The optional settings are: [On]; [Off].

Quiet Boot

The optional settings are: [Disabled]; [Enabled].

Boot Option Priorities

Boot Option #1

Use this item to decide system boot order from available options.

The optional settings are: [UEFI: Built-in EFI Shell]; [Disabled].

UEFI Boot

The optional settings are: [Disabled]; [Enabled].

3-11 Save & Exit Menu

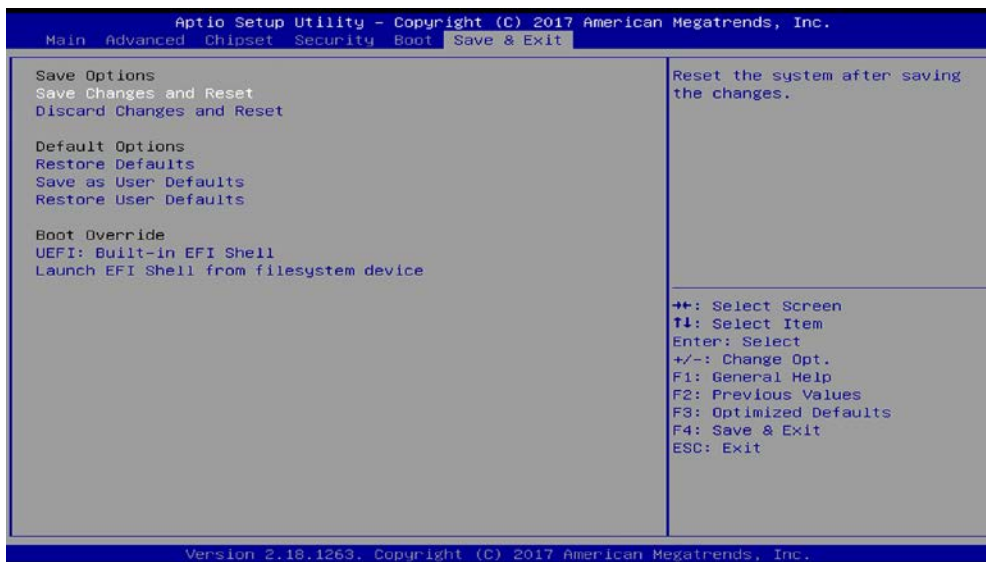

Save Changes and Reset

This item allows user to reset the system after saving the changes.

Discard Changes and Reset

This item allows user to reset the system without saving any changes.

Restore Defaults

Use this item to restore /load default values for all the setup options.

Save as User Defaults

Use this item to save the changes done so far as user defaults.

Restore User Defaults

Use this item to restore defaults to all the setup options.

Boot Override

UEFI: Built-in EFI Shell

Press this item to select the device as boot disk after save configuration and reset

Launch EFI Shell from filesystem device

Press this item to launch EFI Shell application (Shell.efi) from one of the available file system device.