



C7C232-CB-ML

USER'S MANUAL

Revision 1.0

The information in this User's Manual has been carefully reviewed and is believed to be accurate. The vendor assumes no responsibility for any inaccuracies that may be contained in this document, and makes no commitment to update or to keep current the information in this manual, or to notify any person or organization of the updates. **Please Note: For the most up-to-date version of this manual, please see our website at www.supermicro.com.**

Super Micro Computer, Inc. ("Supermicro") reserves the right to make changes to the product described in this manual at any time and without notice. This product, including software and documentation, is the property of Supermicro and/or its licensors, and is supplied only under a license. Any use or reproduction of this product is not allowed, except as expressly permitted by the terms of said license.

IN NO EVENT WILL Super Micro Computer, Inc. BE LIABLE FOR DIRECT, INDIRECT, SPECIAL, INCIDENTAL, SPECULATIVE OR CONSEQUENTIAL DAMAGES ARISING FROM THE USE OR INABILITY TO USE THIS PRODUCT OR DOCUMENTATION, EVEN IF ADVISED OF THE POSSIBILITY OF SUCH DAMAGES. IN PARTICULAR, SUPER MICRO COMPUTER, INC. SHALL NOT HAVE LIABILITY FOR ANY HARDWARE, SOFTWARE, OR DATA STORED OR USED WITH THE PRODUCT, INCLUDING THE COSTS OF REPAIRING, REPLACING, INTEGRATING, INSTALLING OR RECOVERING SUCH HARDWARE, SOFTWARE, OR DATA.

Any disputes arising between manufacturer and customer shall be governed by the laws of Santa Clara County in the State of California, USA. The State of California, County of Santa Clara shall be the exclusive venue for the resolution of any such disputes. Supermicro's total liability for all claims will not exceed the price paid for the hardware product.

FCC Statement: This equipment has been tested and found to comply with the limits for a Class A digital device pursuant to Part 15 of the FCC Rules. These limits are designed to provide reasonable protection against harmful interference when the equipment is operated in a commercial environment. This equipment generates, uses, and can radiate radio frequency energy and, if not installed and used in accordance with the manufacturer's instruction manual, may cause harmful interference with radio communications. Operation of this equipment in a residential area is likely to cause harmful interference, in which case you will be required to correct the interference at your own expense.

California Best Management Practices Regulations for Perchlorate Materials: This Perchlorate warning applies only to products containing CR (Manganese Dioxide) Lithium coin cells. "Perchlorate Material-special handling may apply. See www.dtsc.ca.gov/hazardouswaste/perchlorate".

WARNING: Handling of lead solder materials used in this product may expose you to lead, a chemical known to the State of California to cause birth defects and other reproductive harm.

The products sold by Supermicro are not intended for and will not be used in life support systems, medical equipment, nuclear facilities or systems, aircraft, aircraft devices, aircraft/emergency communication devices or other critical systems whose failure to perform be reasonably expected to result in significant injury or loss of life or catastrophic property damage. Accordingly, Supermicro disclaims any and all liability, and should buyer use or sell such products for use in such ultra-hazardous applications, it does so entirely at its own risk. Furthermore, buyer agrees to fully indemnify, defend and hold Supermicro harmless for and against any and all claims, demands, actions, litigation, and proceedings of any kind arising out of or related to such ultra-hazardous use or sale.

Manual Revision 1.0

Release Date: May 30, 2017

Unless you request and receive written permission from Super Micro Computer, Inc., you may not copy any part of this document. Information in this document is subject to change without notice. Other products and companies referred to herein are trademarks or registered trademarks of their respective companies or mark holders.

Copyright © 2017 by Super Micro Computer, Inc.
All rights reserved.

Printed in the United States of America

Preface

About This Manual

This manual is written for system integrators, IT technicians and knowledgeable end users. It provides information for the installation and use of the C7C232-CB-ML motherboard.

About This Motherboard

The Supermicro® C7C232-CB-ML motherboard supports an Intel® Xeon E3-1200 V5 and 6th Generation Core i3/i5/i7 processor in an LGA 1151 socket. With support of the Intel C232 chipset, DDR4 memory, SATA 3.0, and Trusted Platform Module (TPM), this motherboard offers exceptional performance for desktop platforms. It also provides security-enhancing technologies such as Intel vPro, Intel Trusted Execution Technology, and Trusted Platform module. Please note that this motherboard is intended to be installed and serviced by professional technicians only. For processor/memory updates, please refer to our website at <http://www.supermicro.com/products/>.

Conventions Used in the Manual

Special attention should be given to the following symbols for proper installation and to prevent damage done to the components or injury to yourself:



Warning! Indicates important information given to prevent equipment/property damage or personal injury.



Warning! Indicates high voltage may be encountered when performing a procedure.



Important: Important information given to ensure proper system installation or to relay safety precautions.



Note: Additional Information given to differentiate various models or provides information for correct system setup.

Contacting Supermicro

Headquarters

Address: Super Micro Computer, Inc.
980 Rock Ave.
San Jose, CA 95131 U.S.A.

Tel: +1 (408) 503-8000

Fax: +1 (408) 503-8008

Email: marketing@supermicro.com (General Information)
support@supermicro.com (Technical Support)

Website: www.supermicro.com

Europe

Address: Super Micro Computer B.V.
Het Sterrenbeeld 28, 5215 ML
's-Hertogenbosch, The Netherlands

Tel: +31 (0) 73-6400390

Fax: +31 (0) 73-6416525

Email: sales@supermicro.nl (General Information)
support@supermicro.nl (Technical Support)
rma@supermicro.nl (Customer Support)

Website: www.supermicro.nl

Asia-Pacific

Address: Super Micro Computer, Inc.
3F, No. 150, Jian 1st Rd.
Zhonghe Dist., New Taipei City 235
Taiwan (R.O.C)

Tel: +886-(2) 8226-3990

Fax: +886-(2) 8226-3992

Email: support@supermicro.com.tw

Website: www.supermicro.com.tw

Table of Contents

Chapter 1 Introduction

1.1 Checklist.....	8
Quick Reference	11
Quick Reference Table.....	12
Motherboard Features.....	13
1.2 Processor and Chipset Overview.....	17
1.3 Special Features	17
Recovery from AC Power Loss.....	17
1.4 System Health Monitoring.....	18
Onboard Voltage Monitors	18
Fan Status Monitor with Firmware Control	18
Environmental Temperature Control	18
System Resource Alert.....	18
1.5 ACPI Features.....	19
1.6 Power Supply	19
1.7 Super I/O	19
1.8 Advanced Power Management.....	20
Intel® Intelligent Power Node Manager (IPNM).....	20
Management Engine (ME).....	20

Chapter 2 Installation

2.1 Static-Sensitive Devices.....	21
Precautions	21
Unpacking	21
2.2 Motherboard Installation.....	22
Tools Needed	22
Location of Mounting Holes	22
Installing the Motherboard.....	23
2.3 Processor and Heatsink Installation.....	24
Installing the LGA1151 Processor.....	24
Installing an Active CPU Heatsink with Fan	27
Removing the Heatsink.....	29

2.4	Memory Support and Installation	30
	Memory Support.....	30
	DIMM Module Population Configuration	30
	DIMM Module Population Sequence	30
	DIMM Installation	31
	DIMM Removal	31
2.5	Rear I/O Ports	32
2.6	Connectors	36
	Power Connections	36
2.7	Front Control Panel	38
	Headers.....	41
2.8	Jumper Settings	47
	How Jumpers Work.....	47
Chapter 3 Troubleshooting		
3.1	Troubleshooting Procedures	49
	Before Power On	49
	No Power	49
	No Video	50
	System Boot Failure	50
	Memory Errors	50
	Losing the System's Setup Configuration.....	51
	When the System Becomes Unstable	51
3.2	Technical Support Procedures	53
3.3	Frequently Asked Questions	54
3.4	Battery Removal and Installation	55
	Battery Removal.....	55
	Proper Battery Disposal.....	55
	Battery Installation.....	55
3.5	Returning Merchandise for Service.....	56
Chapter 4 BIOS		
4.1	Introduction.....	57
	Starting the Setup Utility	57

4.2 Main Setup	58
4.3 Advanced Setup Configurations.....	61
4.4 Chipset	80
4.5 Security.....	91
4.6 Boot	94
4.7 Save & Exit.....	95
Appendix A BIOS Codes	
Appendix B Software Installation	
B.1 Installing Software Programs	99
B.2 SuperDoctor® 5.....	100
Appendix C Standardized Warning Statements	
Battery Handling.....	101
Product Disposal	103
Appendix D UEFI BIOS Recovery	

Chapter 1

Introduction

Congratulations on purchasing your computer motherboard from an industry leader. Supermicro boards are designed to provide you with the highest standards in quality and performance.

In addition to the motherboard, several important parts that are included with the system are listed below. If anything listed is damaged or missing, please contact your retailer.

1.1 Checklist

Main Parts List		
Description	Part Number	Quantity
Supermicro Motherboard	C7C232-CB-ML	1
SATA Cables		2
I/O Shield		1

Important Links

For your system to work properly, please follow the links below to download all necessary drivers/utilities and the user's manual for your server.

- Supermicro product manuals: <http://www.supermicro.com/support/manuals/>
- Product drivers and utilities: <ftp://ftp.supermicro.com>
- Product safety info: http://www.supermicro.com/about/policies/safety_information.cfm
- If you have any questions, please contact our support team at: support@supermicro.com

This manual may be periodically updated without notice. Please check the Supermicro website for possible updates to the manual revision level.

Figure 1-1. C7C232-CB-ML Motherboard Image

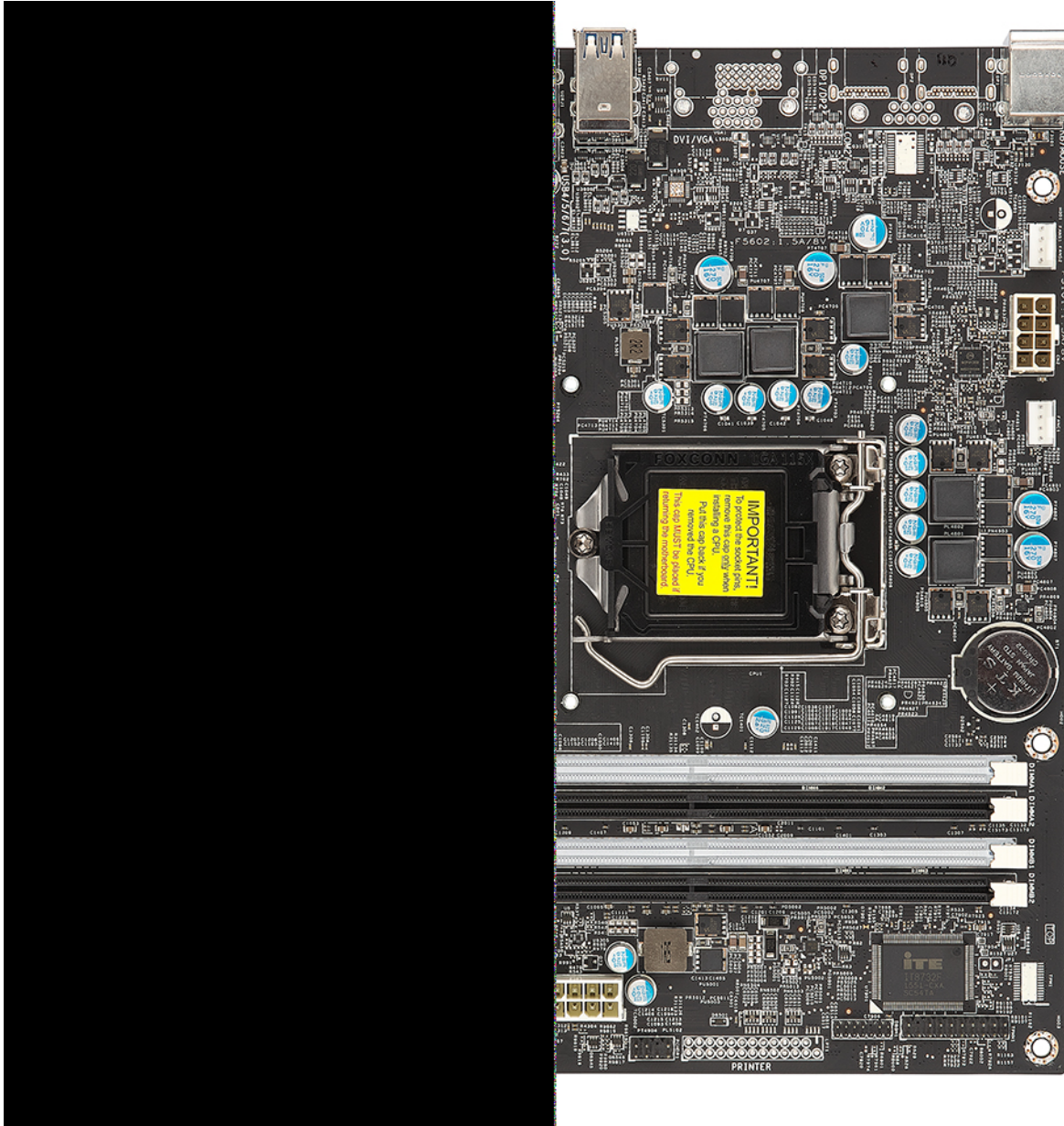

 **Note:** All graphics shown in this manual were based upon the latest PCB revision available at the time of publication of the manual. The motherboard you received may or may not look exactly the same as the graphics shown in this manual.

Figure 1-2. C7C232-CB-ML Motherboard Layout
(not drawn to scale)



Note: Components not documented are for internal testing only.

Quick Reference

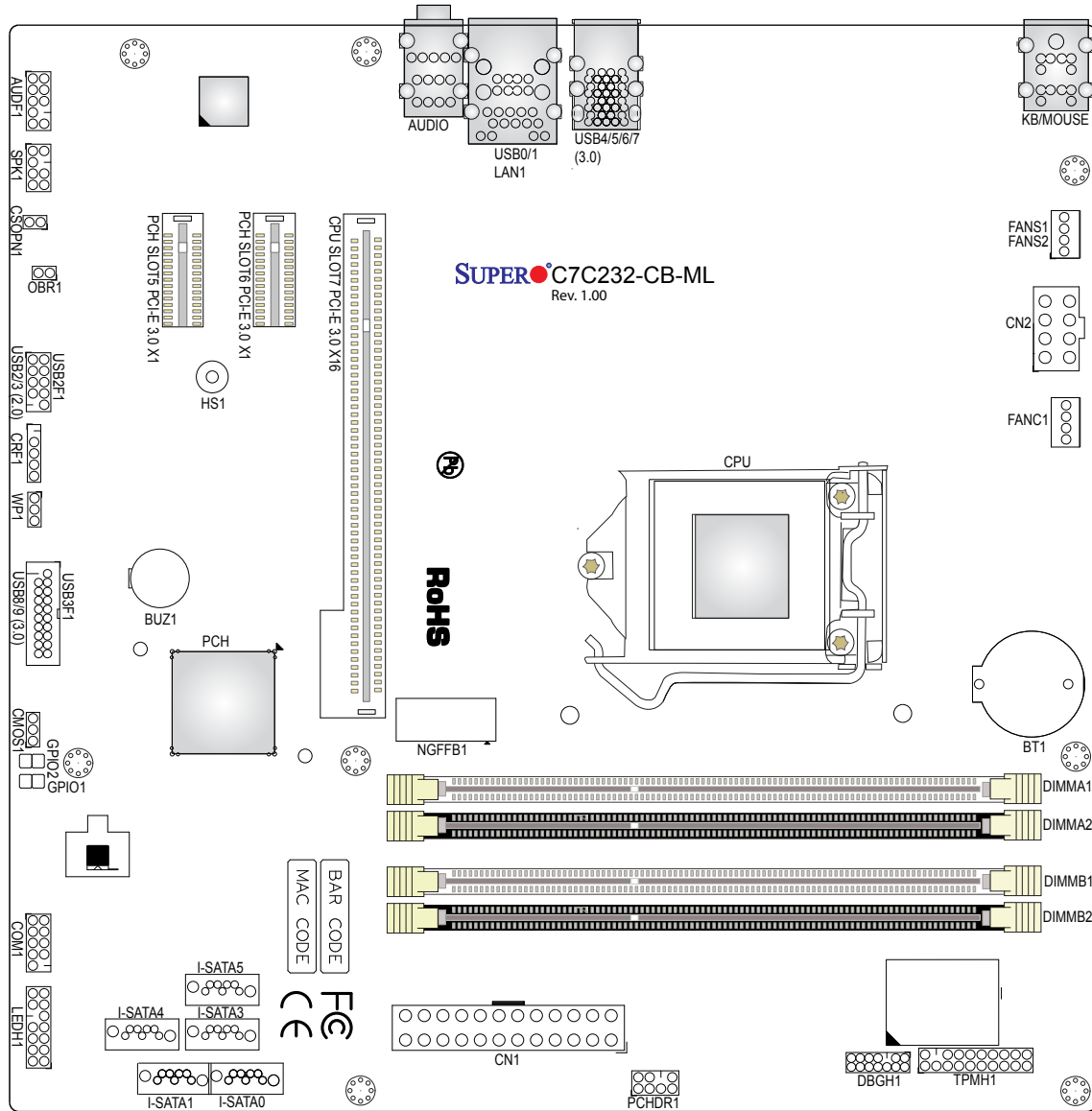
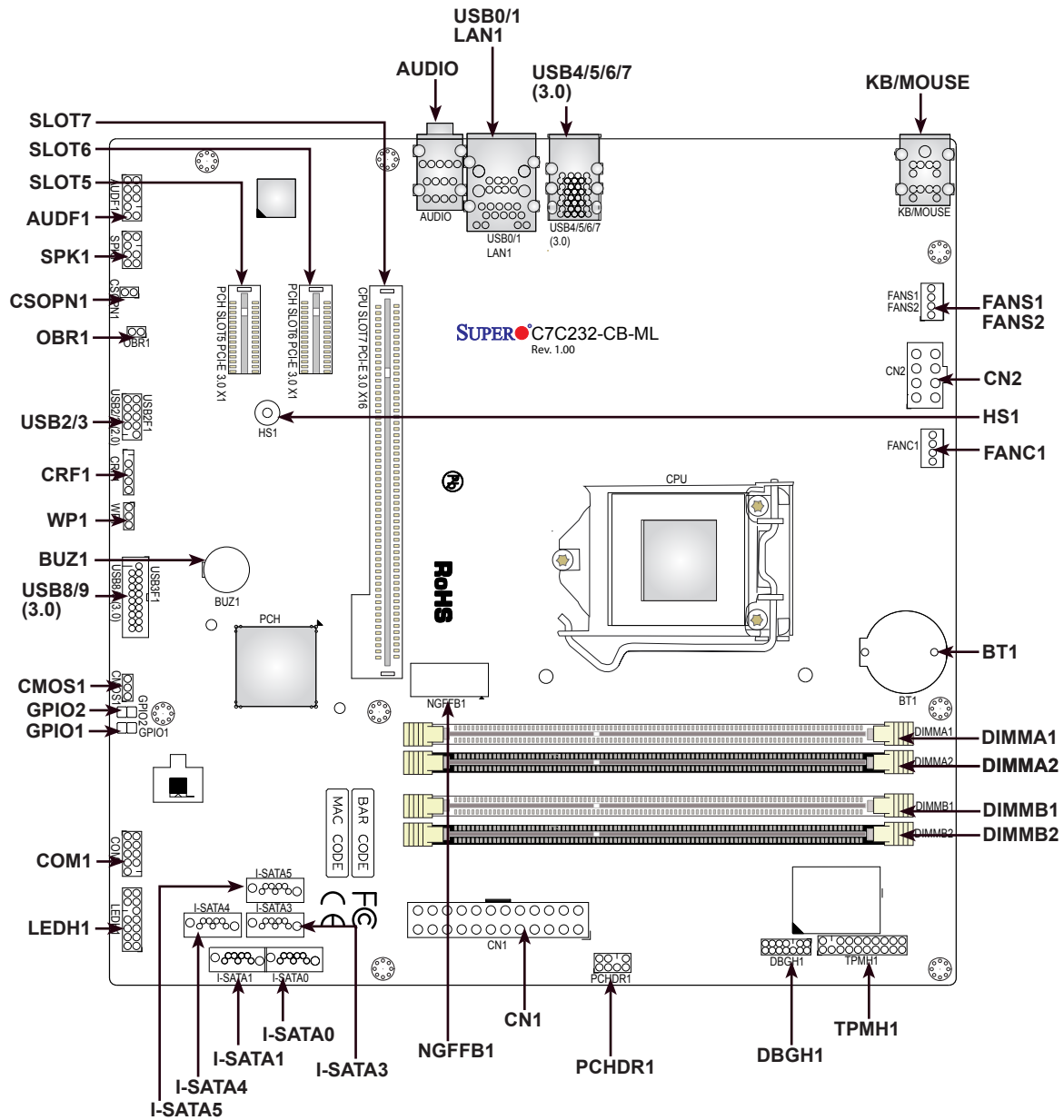

Notes:

- See Chapter 2 for detailed information on jumpers, I/O ports, and JF1 front panel connections.
- "■" indicates the location of Pin 1.
- Jumpers/LED indicators not indicated are used for testing only.
- Please refer to the table on Page 1-3 to see model variations.
- Use only the correct type of onboard CMOS battery as specified by the manufacturer. Do not install the onboard battery upside down to avoid possible explosion.

Quick Reference Table

Jumper	Description	Default Setting
CMOS1	CMOS Clear	Pins 1-2 (Normal), Pins 2-3 (Clear CMOS)
WP1	BIOS Write Protect Header	Pins 2-3 (Enable)

Connector	Description
AUDF1	Front Panel Audio Header
AUDIO	Back Panel Audio Port
BT1	Onboard Battery
BUZ1	Internal Speaker/Buzzer
CN1	24-pin ATX Power Connector
CN2	12V 8-pin Processor Power Connector
COM1	COM Header
CRF1	Front Accessible USB 2.0 Header
CSOPN1	Case Open Detection
FANC1, FANS1/FANS2	System/CPU Fan Headers (FANC1: CPU Fan)
HS1	Mounting Hole
I-SATA0~1, I-SATA3~5	Intel® PCH SATA 3.0 Ports
KB/MOUSE	PS2 Keyboard and Mouse ports
LAN1	LAN (RJ45) Port
LEDH1	Front Panel Header
NGFFB1	M.2 Slot
OBR1	System recovery
PCHDR1	PC Health Header
SLOT5/SLOT6	PCH PCI-E 3.0 X1 Slots
SLOT7	CPU PCI-E 3.0 X16 Slot
SP1	Internal Speaker/Buzzer
SPK1	Speaker Header
TPMH1	Trusted Platform Module/Port 80 Header
USB0/1	Back panel Universal Serial Bus (USB) 2.0 Ports
USB2/3	Front Accessible USB 2.0 Headers
USB4/5/6/7	Back panel USB 3.0 Ports
USB8/9	Front Accessible USB 3.0 Headers

Motherboard Features

Motherboard Features	
CPU	
<ul style="list-style-type: none"> Intel® Xeon E3-1200 V5 processor and Intel 6th Generation Core i3/i5/i7 processor in an LGA1151 socket. 	
Memory	
<ul style="list-style-type: none"> Up to 64GB of DDR4 Non-ECC UDIMM 2133MHz memory, two DIMMs per channel. 	
DIMM Size	
<ul style="list-style-type: none"> Up to 16GB at 1.2V 	
Chipset	
<ul style="list-style-type: none"> Intel PCH C232 	
Expansion Slots	
<ul style="list-style-type: none"> One (1) PCI-E 3.0 X16 Slot Two (2) PCI-E 3.0 X1 Slots 	
Network	
<ul style="list-style-type: none"> Intel i219LM and i219V 	
Graphics	
<ul style="list-style-type: none"> Intel IGD 	
I/O Devices	
<ul style="list-style-type: none"> Serial (COM) Port 	<ul style="list-style-type: none"> One (1) serial header
<ul style="list-style-type: none"> SATA 3.0 	<ul style="list-style-type: none"> Five (5) SATA 3.0 ports supported by Intel PCH C232
<ul style="list-style-type: none"> RAID 	<ul style="list-style-type: none"> RAID 0, 1, 5, 10
Peripheral Devices	
<ul style="list-style-type: none"> Two (2) USB 2.0 ports on the rear I/O panel (USB0/1) Four (4) USB 3.0 ports on the rear I/O panel (USB4/5/6/7) One (2) USB 2.0 header on the motherboard for front access (USB2/3) One (1) USB 3.0 header on the motherboard for front access (USB8/9) 	



Note: The table above is continued on the next page.

Motherboard Features

BIOS

- 128 Mb SPI AMI BIOS® SM Flash UEFI BIOS
- ACPI 4.0, SMBIOS 3.0, Plug-and-Play (PnP), RTC (Real Time Clock) wakeup

Power Management

- Main switch override mechanism
- Power-on mode for AC power recovery
- Intel® Intelligent Power Node Manager 3.0 (available when the Supermicro Power Manager [SPM] is installed and a special power supply is used. See the note on page 22.)
- Management Engine (ME)

System Health Monitoring

- Onboard voltage monitoring for +1.8V, +3.3V, 3.3V standby, +5V, +5V standby, +/-12V, VBAT, HT, Memory, PCH Temp., System Temp., Memory Temp.,
- CPU/system overheat LED and control
- CPU Thermal Trip support
- Status monitor for speed control
- Status monitor for on/off control
- CPU Thermal Design Power (TDP) support of up to 145W (See Note 1 on next page.)

Fan Control

- Fan status monitoring via IPMI connections
- Dual cooling zone
- Low-noise fan speed control
- Pulse Width Modulation (PWM) fan control

System Management

- Trusted Platform Module (TPM) support
- PECI (Platform Environment Control Interface) 2.0 support
- System resource alert via SuperDoctor® 5
- SuperDoctor® 5, Watch Dog, NMI
- Chassis intrusion header and detection

LED Indicators

- Power/suspend-state indicator LED
- HDD activity.

Dimensions

- 9.6" (L) x 9.6" (W) (243.84 mm x 243.84 mm)

 **Note 1:** The CPU maximum thermal design power (TDP) is subject to chassis and heatsink cooling restrictions. For proper thermal management, please check the chassis and heatsink specifications for proper CPU TDP sizing.

Note 2: For IPMI configuration instructions, please refer to the Embedded IPMI Configuration User's Guide available at <http://www.supermicro.com/support/manuals/>.

Note 3: It is strongly recommended that you change BMC login information upon initial system power-on. The manufacture default username is ADMIN and the password is ADMIN. For proper BMC configuration, please refer to http://www.supermicro.com/products/info/files/IPMI/Best_Practices_BMC_Security.pdf

**Figure 1-3.
System Block Diagram**

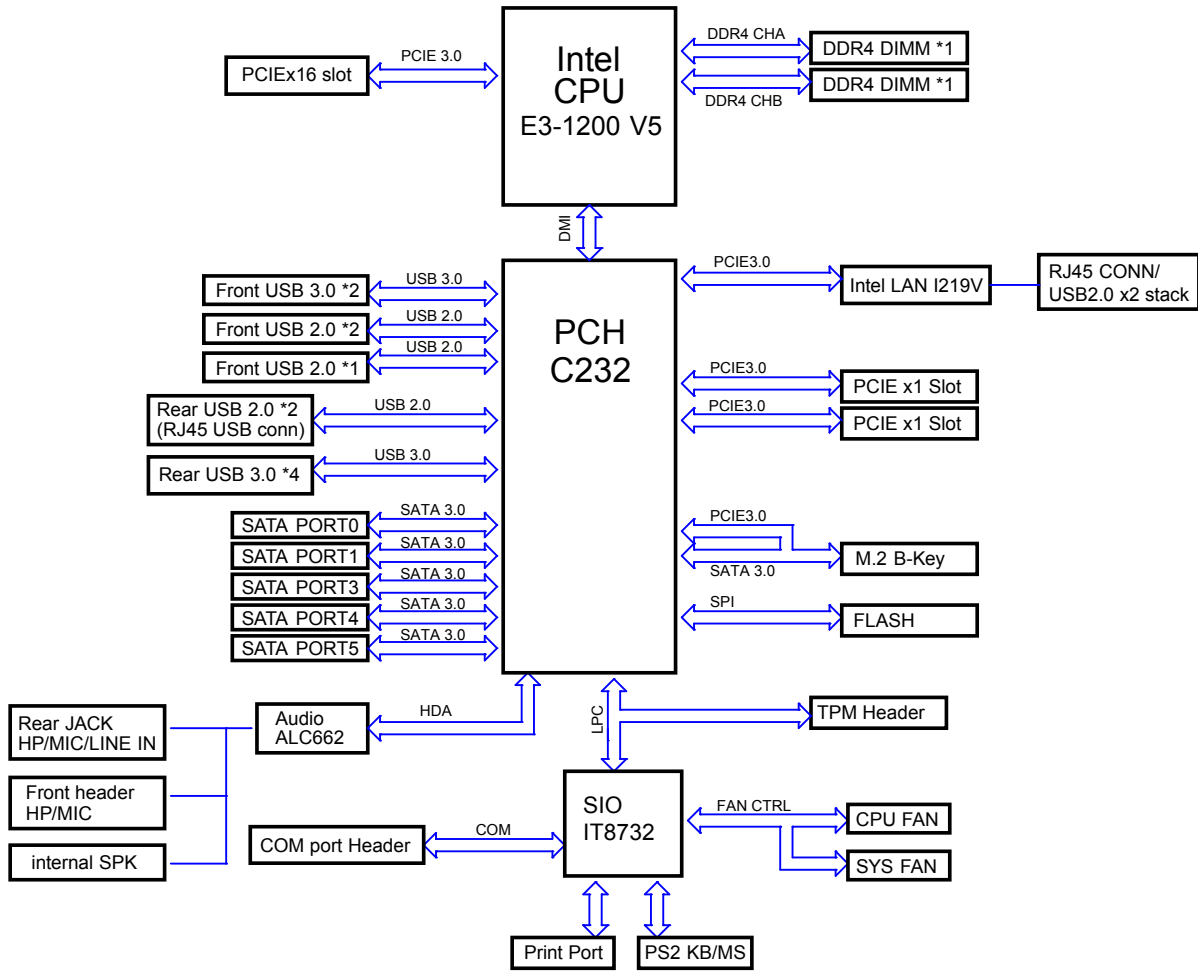

Note: This is a general block diagram and may not exactly represent the features on your motherboard. See the previous pages for the actual specifications of your motherboard.

1.2 Processor and Chipset Overview

Built upon the functionality and capability of the Intel E3-1200 V5 series processors (Socket LGA 1151) and the Intel C232 PCH, the C7C232-CB-ML motherboard offers maximum I/O expandability, energy efficiency, and data reliability in a 14-nm process architecture and is optimized for desktop solutions.

The Intel E3-1200 V5 and PCH C232 platform supports the following features:

- ACPI Power Management Logic Support, Rev. 4.0a
- Intel Turbo Boost Technology
- Configurable TDP (cTDP) and Lower-Power Mode
- Adaptive Thermal Management/Monitoring
- PCI-E 3.0 and SATA 3.0 w/transfer rates of up to 6 Gb/s
- Intel Trusted Execution Technology (Intel TXT)
- Intel Virtualization Technology for Directed I/O (Intel VT-d)

1.3 Special Features

This section describes the health monitoring features of the C7C232-CB-ML motherboard. The motherboard has an onboard System Hardware Monitor chip that supports system health monitoring.

Recovery from AC Power Loss

The Basic I/O System (BIOS) provides a setting that determines how the system will respond when AC power is lost and then restored to the system. You can choose for the system to remain powered off (in which case you must press the power switch to turn it back on), or for it to automatically return to the power-on state. See the Advanced BIOS Setup section for this setting. The default setting is Last State.

1.4 System Health Monitoring

This section describes the health monitoring features of the C7C232-CB-ML motherboard. The motherboard has an onboard Baseboard Management Controller (BMC) chip that supports system health monitoring. Once a voltage becomes unstable, a warning is given or an error message is sent to the screen. The user can adjust the voltage thresholds to define the sensitivity of the voltage monitor.

Onboard Voltage Monitors

The onboard voltage monitor will continuously scan crucial voltage levels. Once a voltage becomes unstable, it will give a warning or send an error message to the screen. Users can adjust the voltage thresholds to define the sensitivity of the voltage monitor. Real time readings of these voltage levels are all displayed in BIOS.

Fan Status Monitor with Firmware Control

The system health monitor embedded in the BMC chip can check the RPM status of the cooling fans. The CPU and chassis fans are controlled via IPMI.

Environmental Temperature Control

System Health sensors in the BMC monitor the temperatures and voltage settings of onboard processors and the system in real time via the IPMI interface. Whenever the temperature of the CPU or the system exceeds a user-defined threshold, system/CPU cooling fans will be turned on to prevent the CPU or the system from overheating.

 **Note:** To avoid possible system overheating, please be sure to provide adequate air-flow to your system.

System Resource Alert

This feature is available when used with SuperDoctor 5®. SuperDoctor 5 is used to notify the user of certain system events. For example, you can configure SuperDoctor 5 to provide you with warnings when the system temperature, CPU temperatures, voltages and fan speeds go beyond a predefined range.

1.5 ACPI Features

ACPI stands for Advanced Configuration and Power Interface. The ACPI specification defines a flexible and abstract hardware interface that provides a standard way to integrate power management features throughout a computer system including its hardware, operating system and application software. This enables the system to automatically turn on and off peripherals such as network cards, hard disk drives and printers.

In addition to enabling operating system-directed power management, ACPI also provides a generic system event mechanism for Plug and Play and an operating system-independent interface for configuration control. ACPI leverages the Plug and Play BIOS data structures while providing a processor architecture-independent implementation that is compatible with Windows 8/R2, and Windows 2012/R2 operating systems.

1.6 Power Supply

As with all computer products, a stable power source is necessary for proper and reliable operation. It is even more important for processors that have high CPU clock rates. In areas where noisy power transmission is present, you may choose to install a line filter to shield the computer from noise. It is recommended that you also install a power surge protector to help avoid problems caused by power surges.

1.7 Super I/O

The Super I/O (ITE8732F) includes a data separator, write pre-compensation circuitry, decode logic, data rate selection, a clock generator, drive interface control logic and interrupt and DMA logic. The wide range of functions integrated onto the Super I/O greatly reduces the number of components required for interfacing with floppy disk drives.

The Super I/O provides two high-speed, 16550 compatible serial communication ports (UARTs), one of which supports serial infrared communication. Each UART includes a 16-byte send/receive FIFO, a programmable baud rate generator, complete modem control capability and a processor interrupt system. Both UARTs provide legacy speed with baud rate of up to 115.2 Kbps as well as an advanced speed with baud rates of 250 K, 500 K, or 1 Mb/s, which support higher speed modems.

The Super I/O provides functions that comply with ACPI (Advanced Configuration and Power Interface), which includes support of legacy and ACPI power management through a SMI or SCI function pin. It also features auto power management to reduce power consumption.

The IRQs, DMAs and I/O space resources of the Super I/O can be flexibly adjusted to meet ISA PnP requirements, which support ACPI and APM (Advanced Power Management).

1.8 Advanced Power Management

The following new advanced power management features are supported by the motherboard.

Intel® Intelligent Power Node Manager (IPNM)

Available when the Supermicro Power Manager (SPM) is installed, Intel's Intelligent Power Node Manager (IPNM) provides your system with real-time thermal control and power management for maximum energy efficiency. Although IPNM Specification Version 2.0/3.0 is supported by the BMC (Baseboard Management Controller), your system must also have IPNM-compatible Management Engine (ME) firmware installed to use this feature.

 **Note:** Support for IPNM 2.0/3.0 support is dependent on the power supply used in the system.

Management Engine (ME)

The Management Engine, which is an ARC controller embedded in the IOH (I/O Hub), provides Server Platform Services (SPS) to your system. The services provided by SPS are different from those provided by the ME on client platforms.

Chapter 2

Installation

2.1 Static-Sensitive Devices

Electrostatic Discharge (ESD) can damage electronic components. To prevent damage to your motherboard, it is important to handle it very carefully. The following measures are generally sufficient to protect your equipment from ESD.

Precautions

- Use a grounded wrist strap designed to prevent static discharge.
- Touch a grounded metal object before removing the board from the antistatic bag.
- Handle the board by its edges only; do not touch its components, peripheral chips, memory modules or gold contacts.
- When handling chips or modules, avoid touching their pins.
- Put the motherboard and peripherals back into their antistatic bags when not in use.
- For grounding purposes, make sure that your chassis provides excellent conductivity between the power supply, the case, the mounting fasteners and the motherboard.
- Use only the correct type of CMOS onboard battery as specified by the manufacturer. Do not install the CMOS battery upside down, which may result in a possible explosion.

Unpacking

The motherboard is shipped in antistatic packaging to avoid static damage. When unpacking the motherboard, make sure that the person handling it is static protected.

2.2 Motherboard Installation

All motherboards have standard mounting holes to fit different types of chassis. Make sure that the locations of all the mounting holes for both the motherboard and the chassis match. Although a chassis may have both plastic and metal mounting fasteners, metal ones are highly recommended because they ground the motherboard to the chassis. Make sure that the metal standoffs click in or are screwed in tightly.

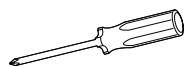

Phillips Screwdriver (1)



Phillips Screws (8)



Standoffs (8)
Only if Needed

Tools Needed

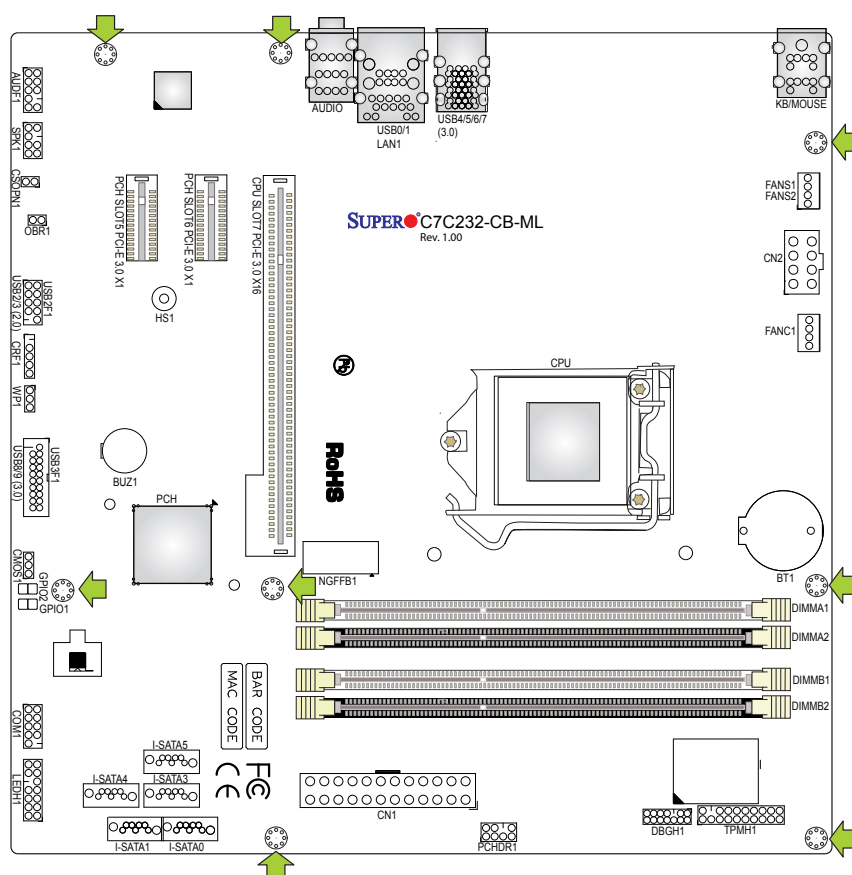

Location of Mounting Holes



Note: 1) To avoid damaging the motherboard and its components, please do not use a force greater than 8 lb/inch on each mounting screw during motherboard installation. 2) Some components are very close to the mounting holes. Please take precautionary measures to avoid damaging these components when installing the motherboard to the chassis.

Installing the Motherboard

1. Install the I/O shield into the back of the chassis.

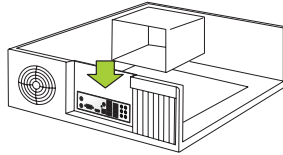

2. Locate the mounting holes on the motherboard. See the previous page for the location.

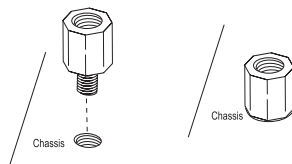

3. Locate the matching mounting holes on the chassis. Align the mounting holes on the motherboard against the mounting holes on the chassis.

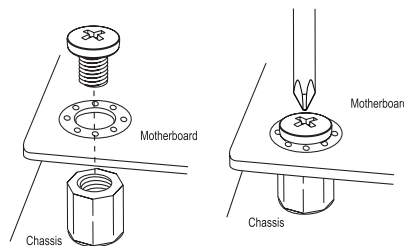

4. Install standoffs in the chassis as needed.
5. Install the motherboard into the chassis carefully to avoid damaging other motherboard components.
6. Using the Phillips screwdriver, insert a Phillips head #6 screw into a mounting hole on the motherboard and its matching mounting hole on the chassis.
7. Repeat Step 5 to insert #6 screws into all mounting holes.
8. Make sure that the motherboard is securely placed in the chassis.

 **Note:** Images displayed are for illustration only. Your chassis or components might look different from those shown in this manual.

2.3 Processor and Heatsink Installation

Warning: When handling the processor package, avoid placing direct pressure on the label area of the fan.



Important:

- Always connect the power cord last, and always remove it before adding, removing or changing any hardware components. Make sure that you install the processor into the CPU socket before you install the CPU heatsink.
- If you buy a CPU separately, make sure that you use an Intel-certified multi-directional heatsink only.
- Make sure to install the motherboard into the chassis before you install the CPU heatsink.
- When receiving a motherboard without a processor pre-installed, make sure that the plastic CPU socket cap is in place and none of the socket pins are bent; otherwise, contact your retailer immediately.
- Refer to the Supermicro website for updates on CPU support.

Installing the LGA1151 Processor

1. Press the load lever to release the load plate, which covers the CPU socket, from its locking position.

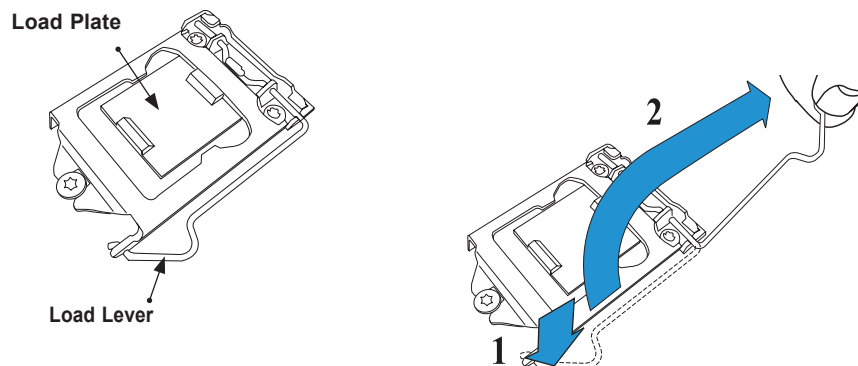

2. Gently lift the load lever to open the load plate. Remove the plastic cap.

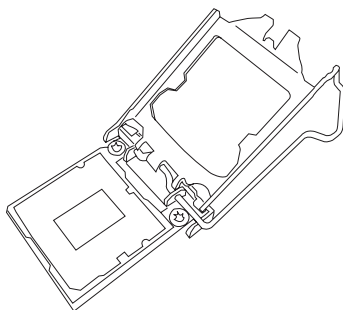

3. Use your thumb and your index finger to hold the CPU at the north center edge and the South center edge of the CPU.

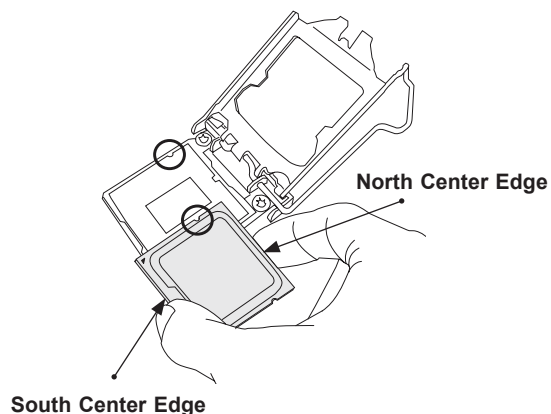

4. Align the CPU key that is the semi-circle cutouts against the socket keys. Once it is aligned, carefully lower the CPU straight down into the socket. (Do not drop the CPU on the socket. Do not move the CPU horizontally or vertically.)

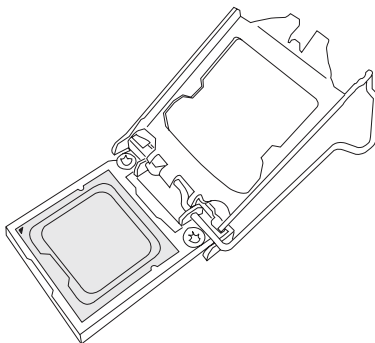

5. Do not rub the CPU against the surface or against any pins of the socket to avoid damaging the CPU or the socket.

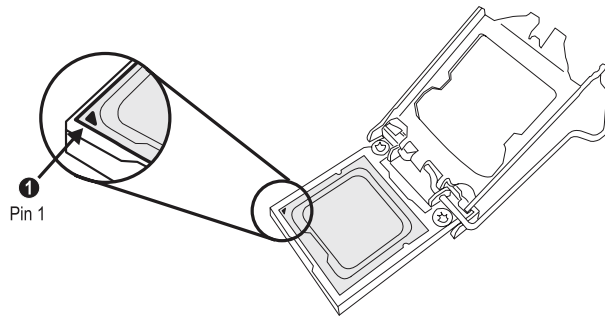

6. With the CPU inside the socket, inspect the four corners of the CPU to make sure that the CPU is properly installed.
7. Use your thumb to gently push the load lever down to the lever lock.

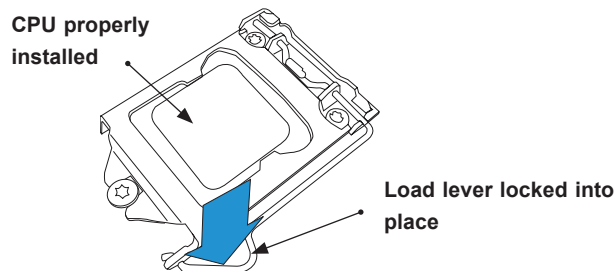

 **Note:** You can only install the CPU inside the socket in one direction. Make sure that it is properly inserted into the CPU socket before closing the load plate. If it doesn't close properly, do not force it as it may damage your CPU. Instead, open the load plate again and double-check that the CPU is aligned properly.

Installing an Active CPU Heatsink with Fan

1. Locate the CPU fan power connector on the motherboard. (Refer to the layout on the right for the CPU Fan location.)
2. Position the heatsink so that the heatsink fan wires are closest to the CPU fan power connector and are not interfered with other components.
3. Inspect the CPU fan wires to make sure that the wires are routed through the bottom of the heatsink.
4. Remove the thin layer of the protective film from the heatsink.



Important: CPU overheating may occur if the protective film is not removed from the heatsink.

5. Apply the proper amount of thermal grease on the CPU.



Note: If your heatsink came with a thermal pad, please ignore this step.

6. If necessary, rearrange the wires to make sure that the wires are not pinched between the heatsink and the CPU. Also make sure to keep clearance between the fan wires and the fins of the heatsink.

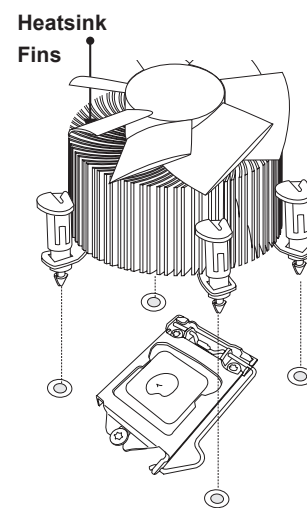
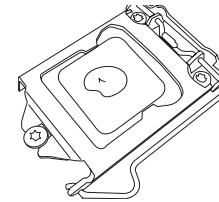
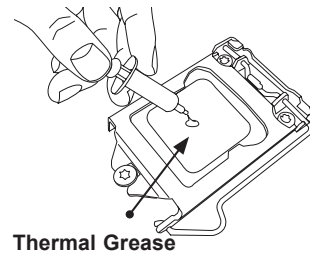

7. Align the four heatsink fasteners with the mounting holes on the motherboard. Gently push the pairs of diagonal fasteners (#1 & #2, and #3 & #4) into the mounting holes until you hear a click. Also, make sure to orient each fastener so that the narrow end of the groove is pointing outward.
8. Repeat step 7 to insert all four heatsink fasteners into the mounting holes.
9. Once all four fasteners are securely inserted into the mounting holes, and the heatsink is properly installed on the motherboard, connect the heatsink fan wires to the CPU fan connector.

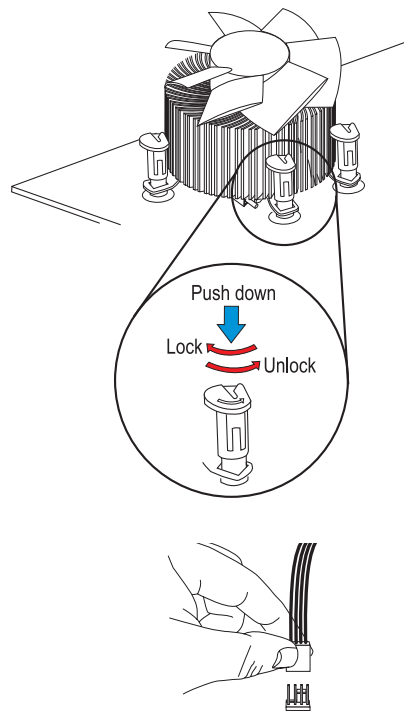

Removing the Heatsink

 **Note:** We do not recommend that the CPU or the heatsink be removed. However, if you do need to remove the heatsink, please follow the instructions below to remove the heatsink and to prevent damage done to the CPU or other components.

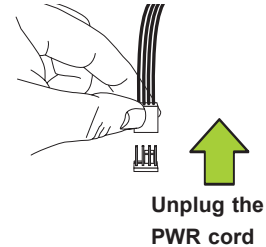

Active Heatsink Removal

1. Unplug the power cord from the power supply.
2. Disconnect the heatsink fan wires from the CPU fan header.
3. Gently press on the fastener cap, turn it counterclockwise to make a 1/4 (90°) turn and pull the fastener upward to loosen it.
4. Repeat step 3 to loosen all fasteners from the mounting holes.
5. With all fasteners loosened, remove the heatsink from the CPU.

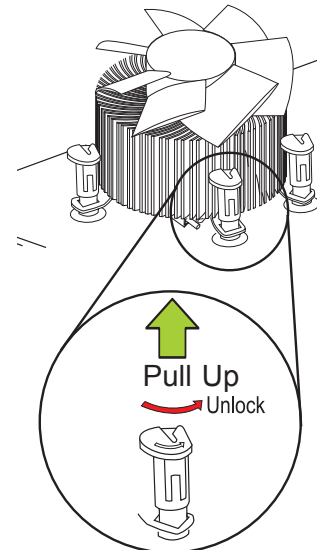

2.4 Memory Support and Installation



Note: Check the Supermicro website for recommended memory modules.



Important: Exercise extreme care when installing or removing DIMM modules to prevent any possible damage.

Memory Support

The C7C232-CB-ML supports up to 32GB of DDR4 Non-ECC UDIMM 2133MHz memory. Populating these DIMM modules with a pair of memory modules of the same type and size will result in interleaved memory, which will improve memory performance.

DIMM Module Population Configuration

For optimal memory performance, follow the table below when populating memory.

Recommended Population (Balanced)				
DIMMA1	DIMMB1	DIMMA2	DIMMB2	Total System Memory
		4GB	4GB	8GB
4GB	4GB	4GB	4GB	16GB
		8GB	8GB	16GB
8GB	8GB	8GB	8GB	32GB
		16GB	16GB	32GB
16GB	16GB	16GB	16GB	64GB

DIMM Module Population Sequence

When installing memory modules, the DIMM slots must be populated in the following order: DIMMB2, DIMMA2, then DIMMB1, DIMMA1. The blue slots must be populated first.

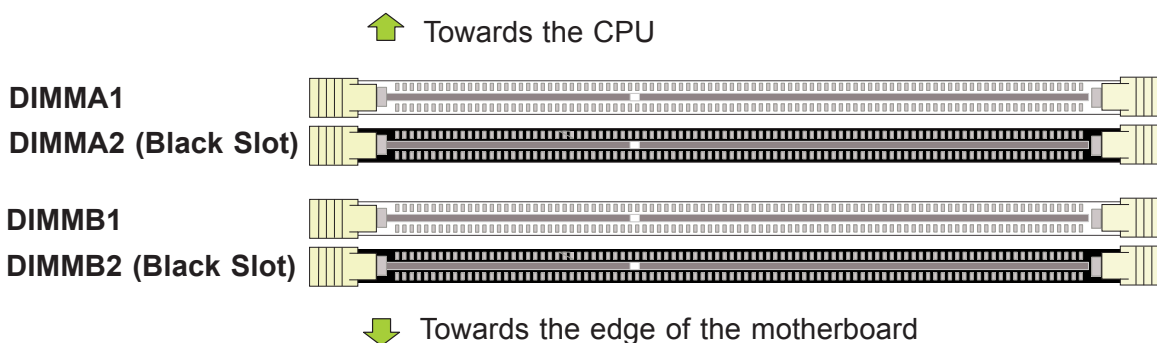

Note: Be sure to use memory modules of the same type and speed. Mixing of memory modules of different types and speeds is not allowed.

DIMM Installation

1. Insert DIMM modules in the following order: DIMMB2, DIMMA2, then DIMMB1, DIMMA1. For the system to work properly, please use memory modules of the same type and speed on the motherboard.
2. Push the release tabs outwards on both ends of the DIMM slot to unlock it.
3. Align the key of the DIMM module with the receptive point on the memory slot.
4. Align the notches on both ends of the module against the receptive points on the ends of the slot.
5. Use two thumbs together to press the notches on both ends of the module straight down into the slot until the module snaps into place.
6. Press the release tabs to the lock positions to secure the DIMM module into the slot.

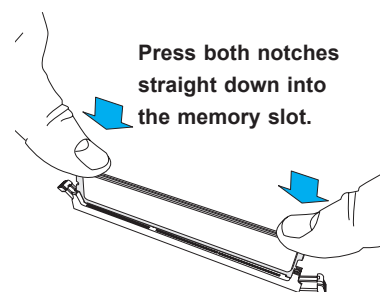
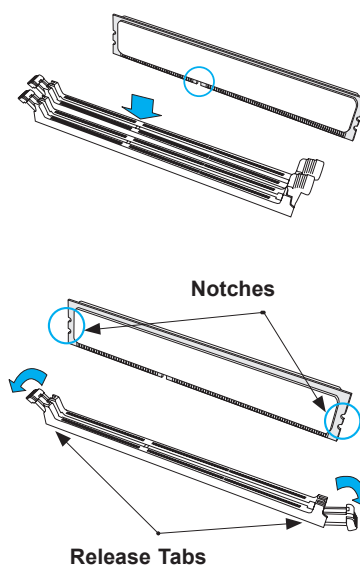
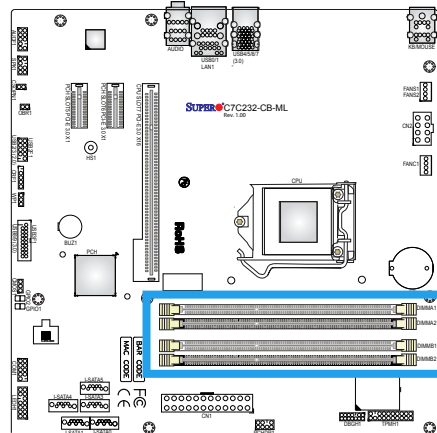

DIMM Removal

Reverse the steps above to remove the DIMM modules from the motherboard.

2.5 Rear I/O Ports

See Figure 2-2 below for the locations and descriptions of the various I/O ports on the rear of the motherboard.

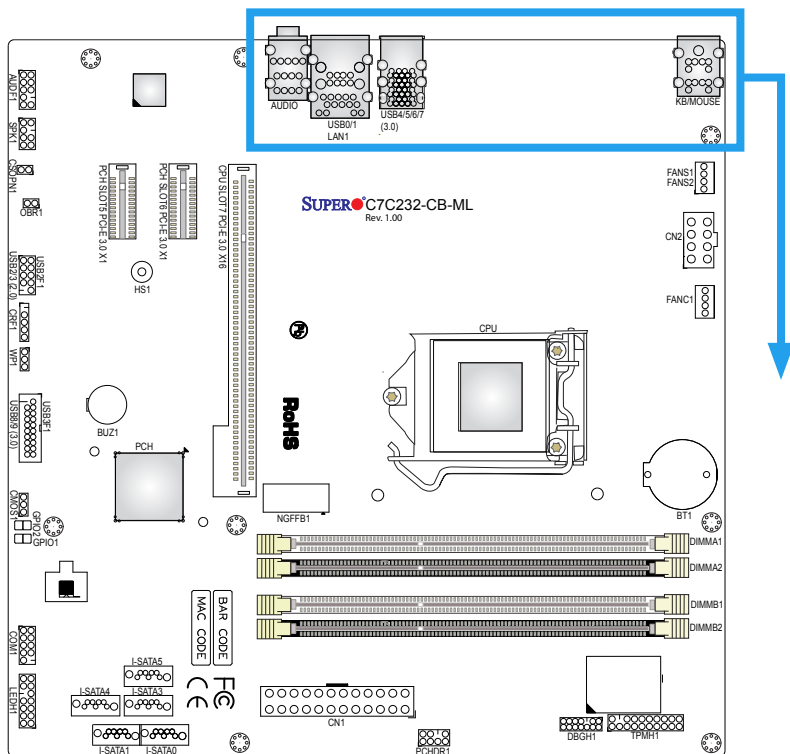
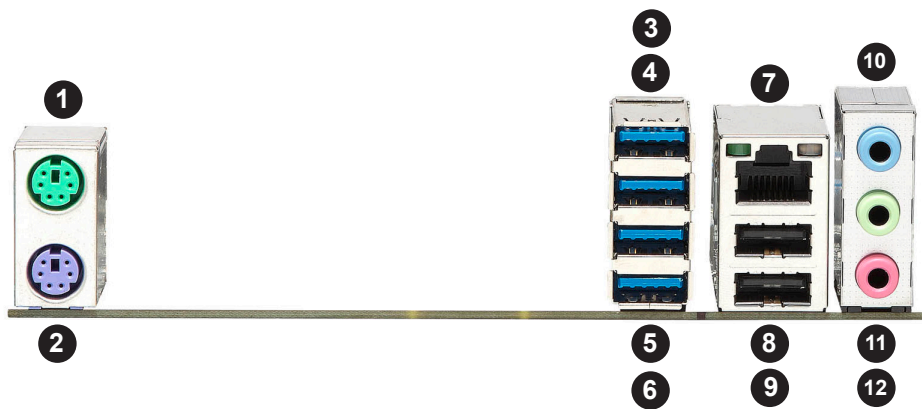

Figure 2-2. I/O Port Locations and Definitions



Rear I/O Ports					
#	Description	#	Description	#	Description
1.	Keyboard	5.	USB6 (3.0)	9.	USB1
2.	Mouse	6.	USB7 (3.0)	10.	Audio Line In
3.	USB4 (3.0)	7.	LAN1	11.	Audio Line Out
4.	USB5 (3.0)	8.	USB0	12.	Audio Mic In

LAN Port

One LAN port (LAN1) is located on the I/O back panel. This port accepts RJ45 type cables.

Serial Port

There is one COM header (COM1) on the motherboard to provide front side access.

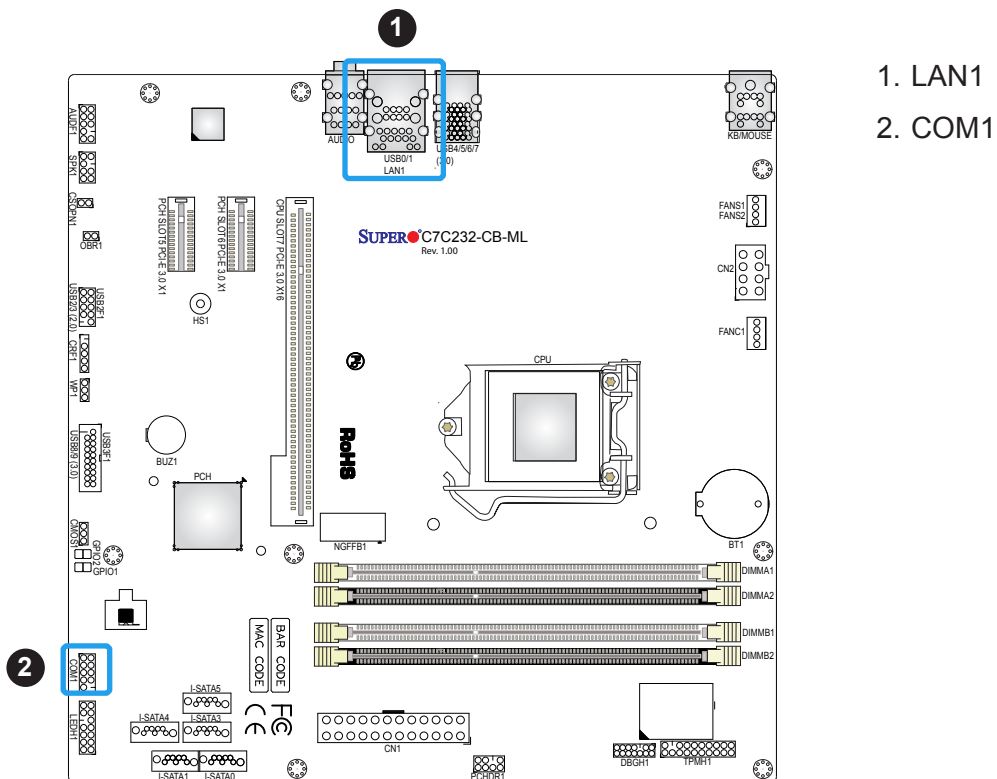

KB/MOUSE

The PS2 keyboard and mouse ports are located on the I/O back panel.

KB/MOUSE Pin Definitions			
Keyboard		Mouse	
Pin	Defintion	Pin	Defintion
1	KB Data	1	Mouse Data
2	No Connection	2	No Connection
3	Ground	3	Ground
4	Mouse/KB VCC (+5V)	4	Mouse/KB VCC (+5V)
5	KB Clock	5	Mouse Clock
6	No Connection	6	No Connection

AUDIO Port

The audio ports on the I/O back panel provide three connections. From top to bottom: Audio Line In (blue), Audio Line Out (green), and Audio Mic In (pink).

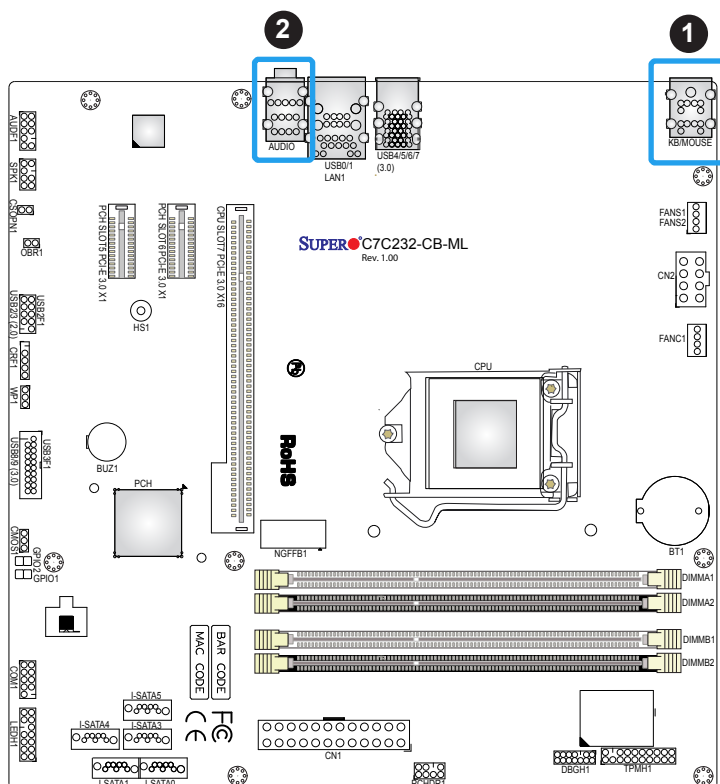

- 1. KB/MOUSE
- 2. AUDIO

Universal Serial Bus (USB) Ports

There are two USB 2.0 ports (USB0/1) and four USB 3.0 ports (USB4/5/6/7) on the I/O back panel. The motherboard also has one USB 2.0 header (USB2/3) and one USB 3.0 header (USB8/9). The onboard headers can be used to provide front side USB access with a cable (not included).

Front Panel USB (3.0) (USB8/9) Pin Definitions			
Pin#	Definition	Pin#	Definition
1	5V_USB30H1	11	USB_CON_PP6
2	USB_RX_CON_N1	12	USB_CON_PN6
3	USB_RX_CON_P1	13	GND
4	GND	14	USB_TX_CON_P2
5	USB_TX_CON_N1	15	USB_TX_CON_N2
6	USB_TX_CON_P1	16	GND
7	GND	17	USB_RX_CON_P2
8	USB_CON_PN5	18	USB_RX_CON_N2
9	USB_CON_PP5	19	5V_USB30H1
10	GND	20	X

Front Panel USB 2.0 (USB2/3) Pin Definitions			
Pin#	Definition	Pin#	Definition
1	5V_USB20H2	2	5V_USB20H2
3	USB_CON_PN9	4	USB_CON_PN7
5	USB_CON_PP9	6	USB_CON_PP7
7	Ground	8	Ground
9	X	10	Ground

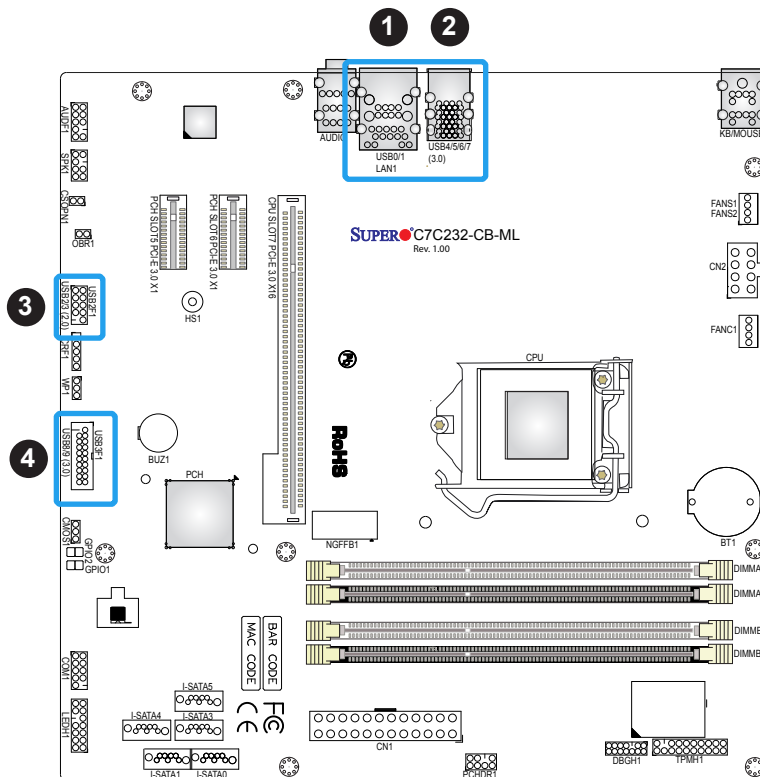

1. USB0/1
2. USB4/5/6/7
3. USB2/3
4. USB8/9

2.6 Connectors

Power Connections

Main ATX Power Supply Connector

The primary power supply connector (CN1) meets the ATX SSI EPS 24-pin specification. You must also connect the 8-pin (CN2) processor power connector to your power supply.

ATX Power 24-pin Connector Pin Definitions			
Pin#	Definition	Pin#	Definition
13	+3.3V	1	+3.3V
14	-12V	2	+3.3V
15	COM	3	COM
16	PS_ON	4	+5V
17	COM	5	COM
18	COM	6	+5V
19	COM	7	COM
20	Res (NC)	8	PWR_OK
21	+5V	9	5VSB
22	+5V	10	+12V
23	+5V	11	+12V
24	COM	12	+3.3V

Required Connection

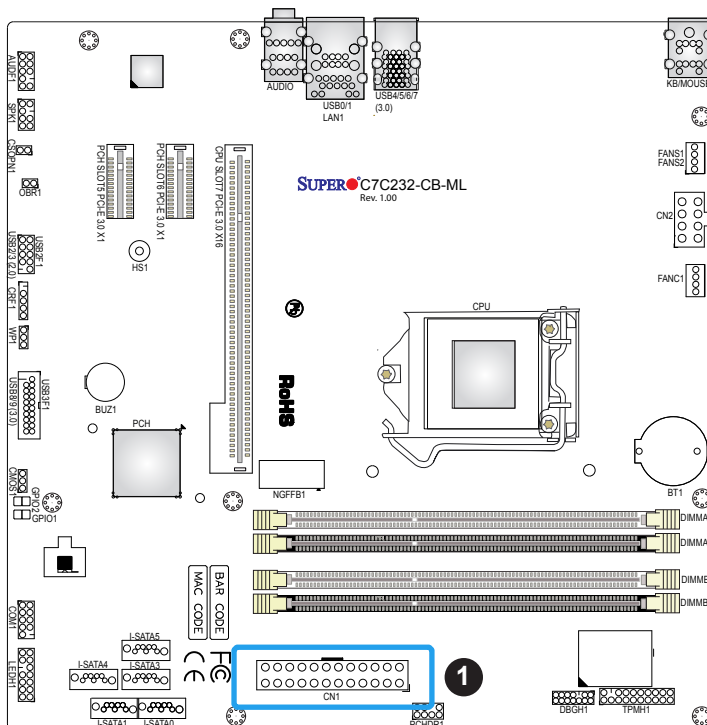

1. 24-Pin ATX Main PWR

Secondary Power Connector

CN2 must also be connected to the power supply. This connector is used to power the processor.

+12V 8-pin Power Pin Definitions	
Pin#	Definition
1 - 4	Ground
5 - 8	+12V

Required Connection

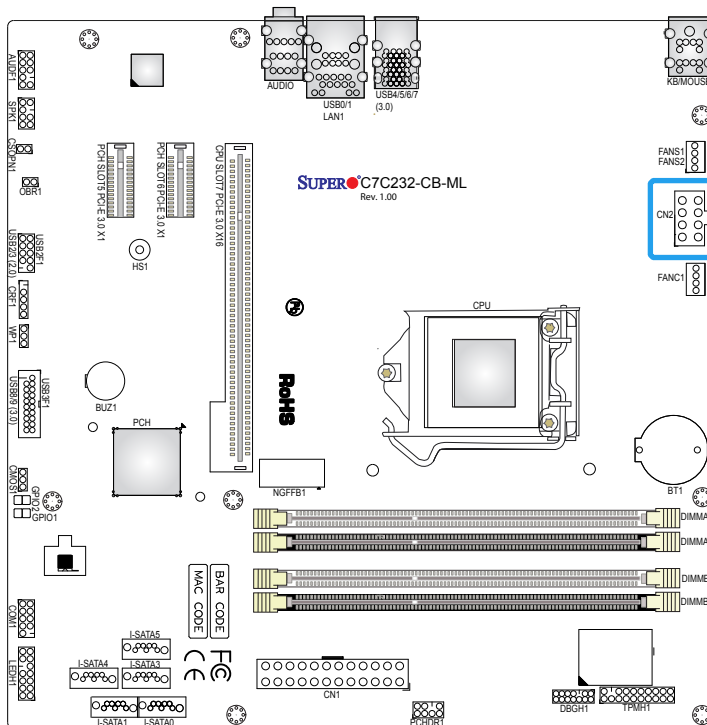

1. 8-Pin PWR

2.7 Front Control Panel

LEDH1 contains header pins for various buttons and indicators that are normally located on a control panel at the front of the chassis. These connectors are designed specifically for use with Supermicro chassis. See the figure below for the descriptions of the front control panel buttons and LED indicators.

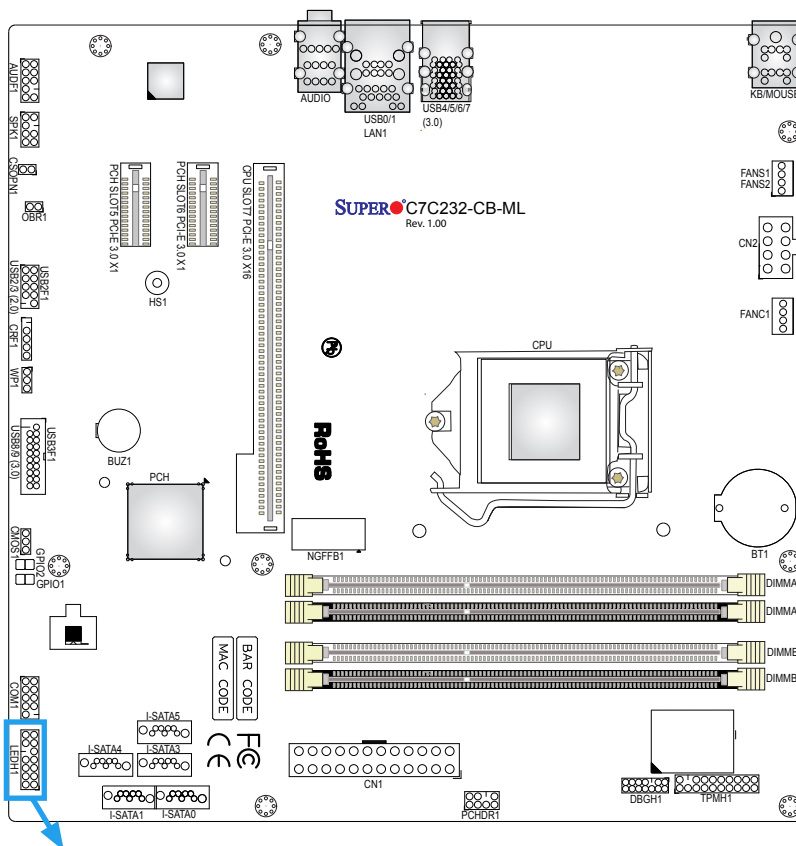

Figure 2-3. LEDH1 Header Pins

	1	2	
SATA LED (+)	○	○	PWR LED (+)
SATA LED (-)	○	○	PWR LED (-)
Ground	○	○	PWR Button
FP Reset	○	○	Ground
X	○	○	X
+5V AUX	○	○	LAN LED
X	○	○	Ground
	13	14	

Power Button

The Power Button connection is located on pins 5 and 6. Attach it to a power switch on the computer case to power on the system.

Power Button Pin Definitions	
Pins	Definition
5	Ground
6	PWR BTN

FP Reset Button

The Reset Button connection is located on pins 7 and 8. Attach it to a hardware reset switch on the computer case to reset the system.

Reset Button Pin Definitions	
Pins	Definition
7	FP Reset
8	Ground

LAN LED

The LAN LED connection for LAN ports is located on pins 11 and 12. Attach an NIC LED cable to display network activities. Refer to the table below for pin definitions.

HDD LED Pin Definitions	
Pins	Definition
11	+5V AUX
12	LAN LED

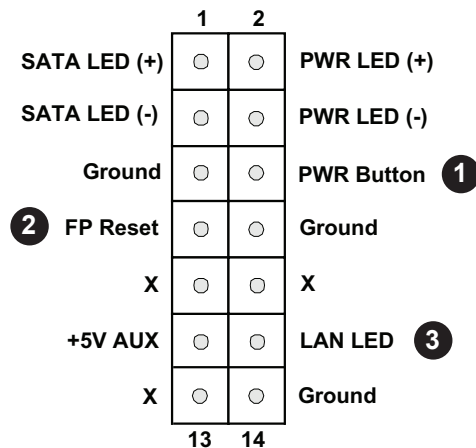

1. PWR Button
2. Front Panel Reset
3. LAN LED

Power LED

The Power LED connection is located on pins 2 and 4.

Power LED Pin Definitions	
Pins	Definition
2	PWR LED (+)
4	PWR LED (-)

HD LED PWR/SATA LED

The SATA LED connection is located on pins 1 and 3. Attach a cable here to indicate the status of SATA-related activities.

SATA LED Pin Definitions	
Pins	Definition
1	SATA LED (+)
3	SAT LED (-)

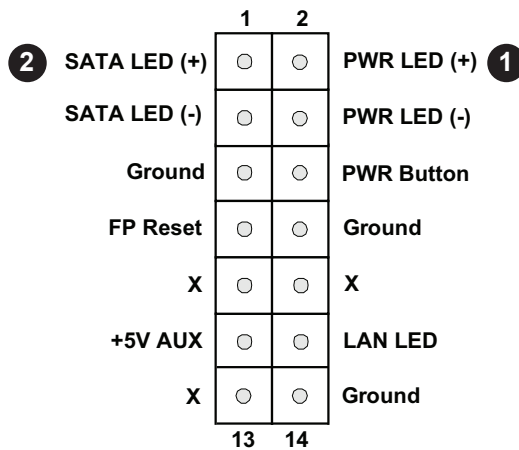

- 1. PWR LED
- 2. SATA HDD LED

Headers

Fan Headers

There are two fan headers on the motherboard. FANC1 is the CPU fan, and FANS1 is the system fan. These are 4-pin fan headers; pins 1-3 are backward compatible with traditional 3-pin fans. The onboard fan speeds are controlled by Thermal Management (via Hardware Monitoring) in the BIOS. When using Thermal Management setting, please use all 3-pin fans or all 4-pin fans.

Fan Header Pin Definitions	
Pin#	Definition
1	Ground
2	+12V (Red)
3	Tachometer
4	PWM Control

Speaker Header

SPK1 is the internal audio speaker header.

Speaker header Pin Definitions			
Pin#	Definition	Pin#	Definition
1	MONO_L	2	AUDIO_GROUND
3	MONO_R	4	X
5	AUDIO_GROUND	6	AUDIO_GROUND
7	MUTE_C	8	5V

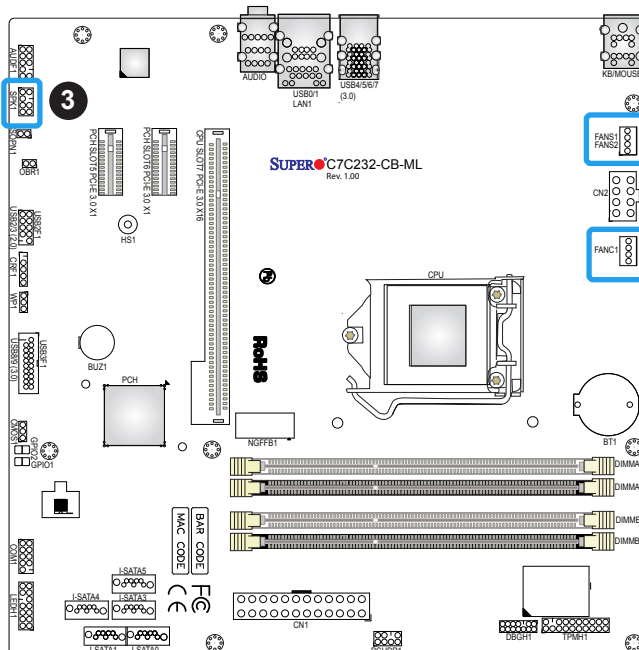

1. FANC1
2. FANS1
3. Speaker Header

Front Panel Audio Header

A 10-pin audio header at AUDF1 allows you to use the onboard sound for audio playback. Connect an audio cable to the audio header to use this feature. See the table below pin definitions.

10-pin Audio Pin Definitions			
Pin#	Definition	Pin#	Definition
1	MIC2_L	2	AUDIO_GROUND
3	MIC2_R	4	FP_AUDIO_PRESENCE
5	FP_OUTR_R	6	MIC2_JD
7	FP_OUTR_SENSE	8	X
9	FP_OUTR_L	10	LINE2_JD

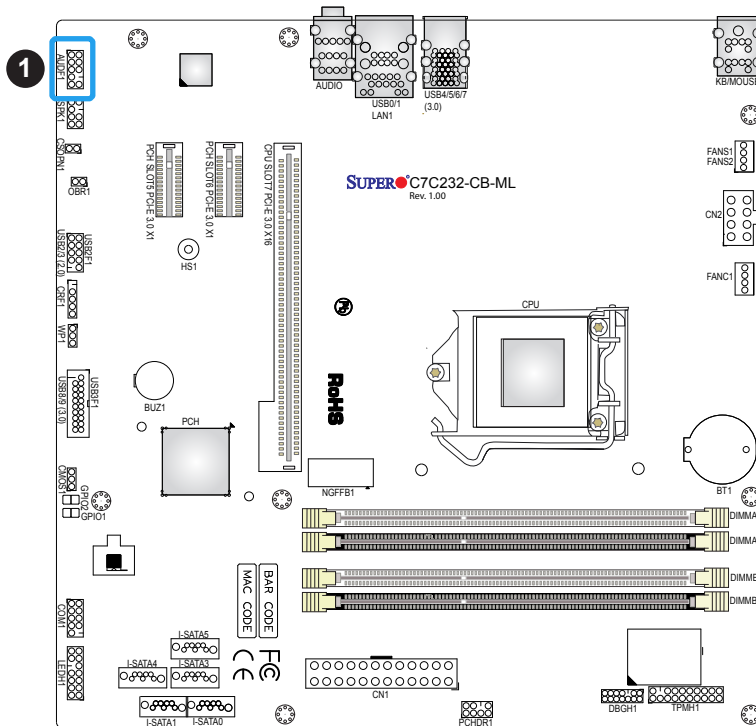

1. Front Panel Audio

TPM Header

The TPMH1 header is used to connect a Trusted Platform Module (TPM), which is available from a third-party vendor. A TPM is a security device that supports encryption and authentication in hard drives. It enables the motherboard to deny access if the TPM associated with the hard drive is not installed in the system. See the table below for pin definitions.

Trusted Platform Module Header Pin Definitions			
Pin#	Definition	Pin#	Definition
1	CLK_PCI_LPC	2	GND
3	LPC_FRAME#	4	No Pin
5	PL_TRST#_PCH	6	X
7	LPC_AD3	8	LPC_AD2
9	3.3VS)	10	LPC_AD1
11	LPC_AD0	12	GND
13	X	14	X
15	P3V3_S5	16	LPC_SERIRQ_PCH
17	GND	18	GND
19	SUS_STAT-N	20	X

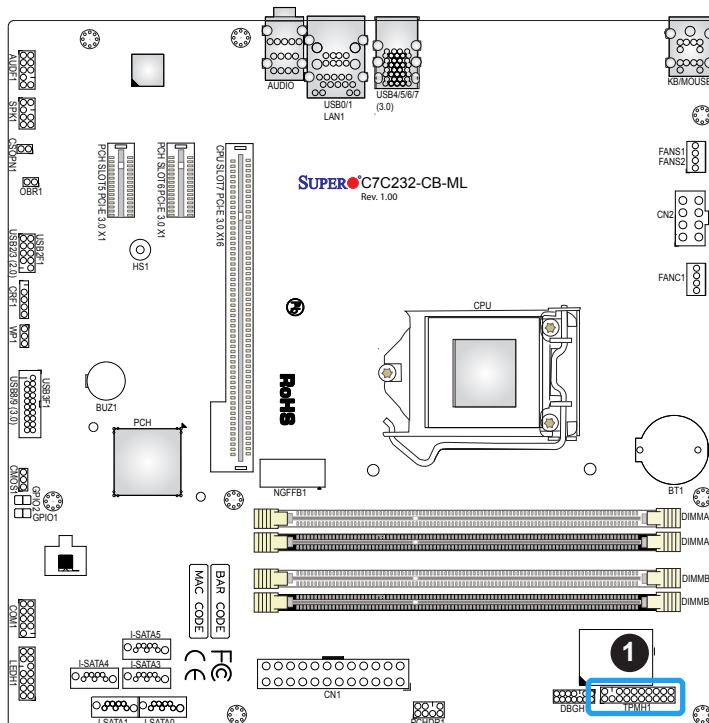

1. TPM Header

PC Health Header

PC health header at PCHDR1 monitors the power supply, fan and system temperatures. See the table below for pin definitions.

PC Health Header Pin Definitions			
Pin#	Definition	Pin#	Definition
1	5V_S0	2	3D3V_S0
3	SMB_CLK_PCHD	4	PLTRST#_PCH
5	SMB_DATA_PCHD	6	No Pin
7	Ground	8	Ground

Case Open Detection

A case open detection header is located at CSOPN1. Attach a cable from the chassis to the header to inform you when the chassis is opened.

Chassis Intrusion Pin Definitions	
Pins	Definition
1	Intrusion Input
2	Ground

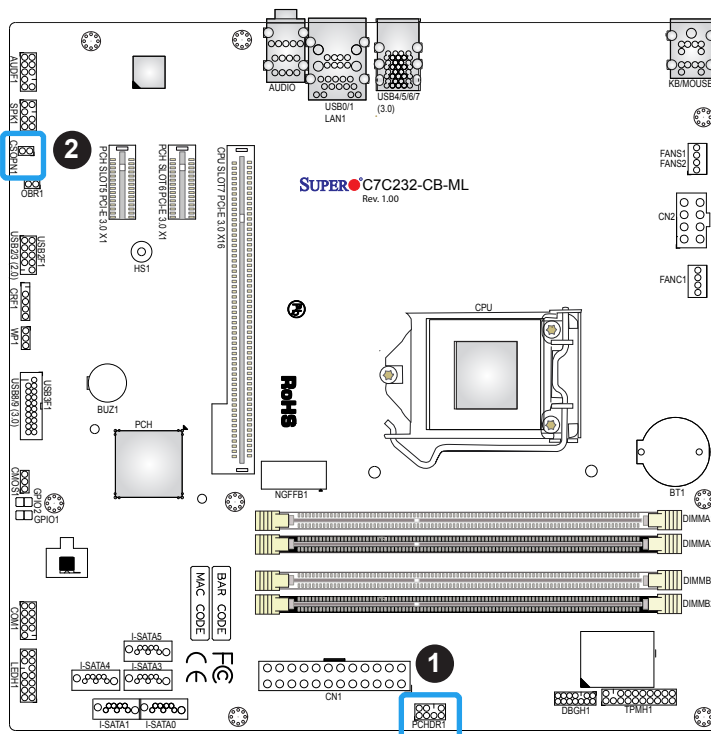

1. PC Health Header
2. Case Open Detection

SATA and SAS Ports

The C7C232-CB-ML has five SATA 3.0 ports that are supported by the Intel PCH C232 chipset.

M.2 Slot

The M.2 slot at NGFFB1 is designed for internal mounting devices. The C7C232-CB-ML motherboard deploys an M key only dedicated for SSD devices with the ultimate performance capability in a PCI Express 3.0 X4 interface for native PCI-E SSD support.

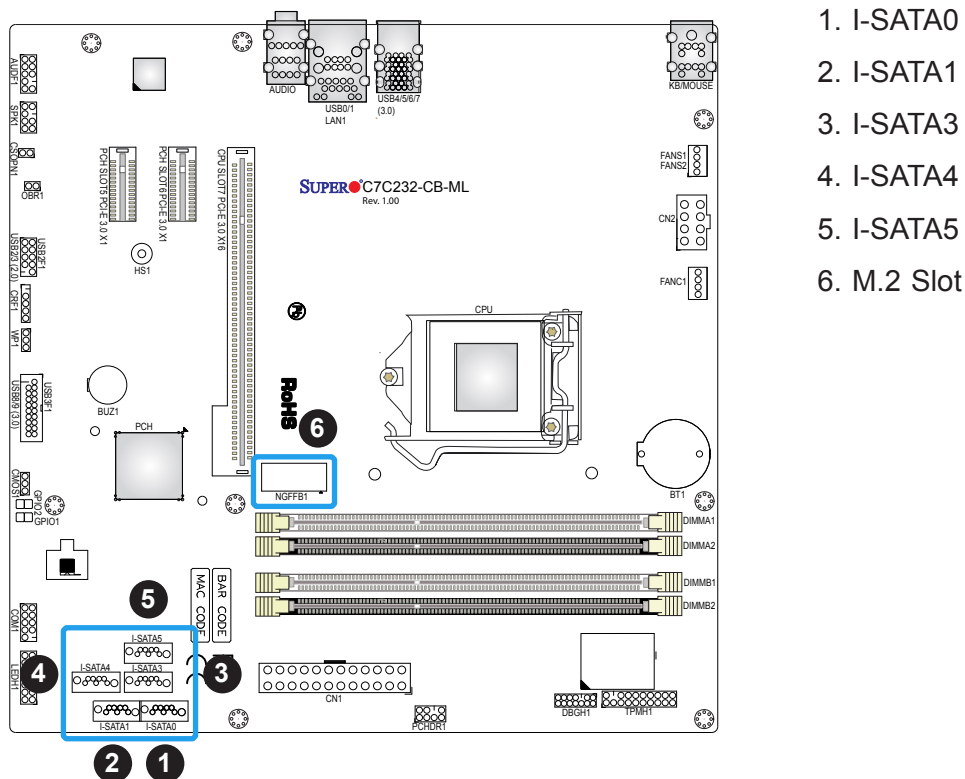

Internal Speaker/Buzzer

The Internal Speaker/Buzzer at BUZ1 is used to provide audible indications for various beep codes. See the table below for pin definitions.

Internal Buzzer Pin Definitions		
Pin#	Definition	
1	Pos (+)	Beep In
2	Neg (-)	Alarm Speaker

Front Accessible USB 2.0 Header

CRF1 is a USB header used to provide front access USB 2.0 connection. See the table below for pin definitions.

USB 2.0 Header Pin Definitions	
Pin#	Definition
1	X
2	Ground
3	USB_CON_PP8
4	USB_CON_PN8
5	5V_USB20H1

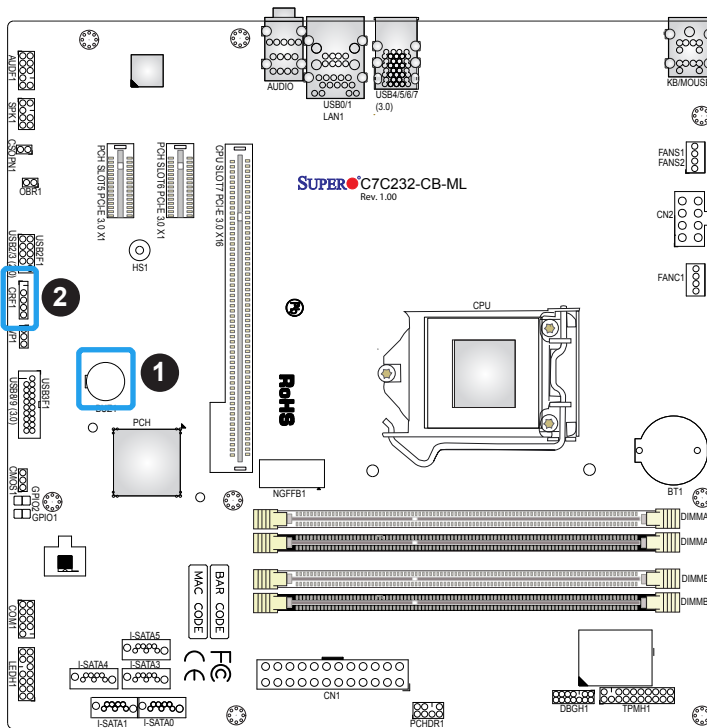

1. Internal Speaker
2. USB 2.0 Header

2.8 Jumper Settings

How Jumpers Work

To modify the operation of the motherboard, jumpers can be used to choose between optional settings. Jumpers create shorts between two pins to change the function of the connector. Pin 1 is identified with a square solder pad on the printed circuit board. See the diagram at right for an example of jumping pins 1 and 2. Refer to the motherboard layout page for jumper locations.

 **Note:** On two-pin jumpers, "Closed" means the jumper is on and "Open" means the jumper is off the pins.

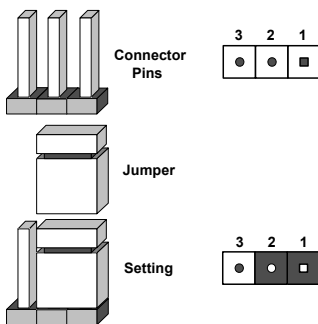

System Recovery

OBR1 is the system recovery jumper. Leave the jumper off (Open) this two-pin jumper for normal operation. Close it for system recovery.

System Recovery Jumper Settings	
Jumper Setting	Definition
Open	Normal
Closed	System recovery

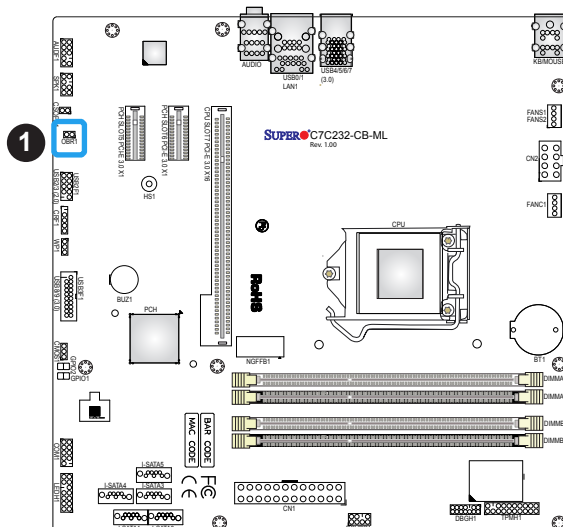

1. System Recovery

CMOS Clear

CMOS1 is used to clear CMOS, which will also clear any passwords.

CMOS Clear Jumper Settings	
Jumper Setting	Definition
Pins 1-2	Normal
Pins 2-3	Clear CMOS

Write Protect Header

WP1 allows you to enable or disable the SPI Flash ROM write protection.

Write Protect header Jumper Settings	
Jumper Setting	Definition
Pins 1-2	Disabled (default)
Pins 2-3	Enabled

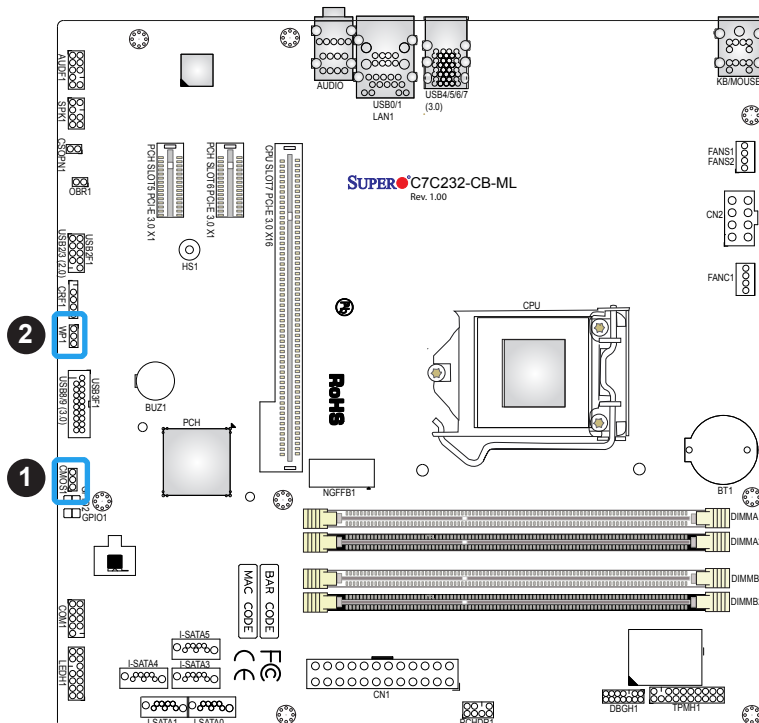

1. CMOS Clear
2. Write Protect Header

Chapter 3

Troubleshooting

3.1 Troubleshooting Procedures

Use the following procedures to troubleshoot your system. If you have followed all of the procedures below and still need assistance, refer to the 'Technical Support Procedures' and/or 'Returning Merchandise for Service' section(s) in this chapter. Always disconnect the AC power cord before adding, changing or installing any non hot-swap hardware components.

Before Power On

1. Check that the power LED on the motherboard is on.
2. Make sure that the power connector is connected to your power supply.
3. Make sure that no short circuits exist between the motherboard and chassis.
4. Disconnect all cables from the motherboard, including those for the keyboard and mouse.
5. Remove all add-on cards.
6. Install a CPU, a heatsink*, and connect the internal speaker and the power LED to the motherboard. Check all jumper settings as well. (Make sure that the heatsink is fully seated.)
7. Use the correct type of onboard CMOS battery (CR2032) as recommended by the manufacturer. To avoid possible explosion, do not install the CMOS battery upside down.

No Power

1. Make sure that no short circuits exist between the motherboard and the chassis.
2. Verify that all jumpers are set to their default positions.
3. Check that the 115V/230V switch on the power supply is properly set.
4. Turn the power switch on and off to test the system.
5. The battery on your motherboard may be old. Check to verify that it still supplies ~3VDC. If it does not, replace it with a new one.

No Video

1. If the power is on but you have no video, remove all the add-on cards and cables.
2. Use the speaker to determine if any beep codes exist. Refer to Appendix A for details on beep codes.



Note: If you are a system integrator, VAR or OEM, a POST diagnostics card is recommended. For I/O port 80h codes, refer to Appendix B.

System Boot Failure

If the system does not display POST (Power-On-Self-Test) or does not respond after the power is turned on, check the following:

1. Check for any error beep from the motherboard speaker.
 - If there is no error beep, try to turn on the system without DIMM modules installed. If there is still no error beep, replace the motherboard.
 - If there are error beeps, clear the CMOS settings by unplugging the power cord and contacting both pads on the CMOS Clear Jumper (JBT1). Refer to chapter 2.
2. Remove all components from the motherboard, especially the DIMM modules. Make sure that system power is on and that memory error beeps are activated.
3. Turn on the system with only one DIMM module installed. If the system boots, check for bad DIMM modules or slots by following the Memory Errors Troubleshooting procedure in this Chapter.

Memory Errors

1. Make sure that the DIMM modules are properly and fully installed.
2. Confirm that you are using the correct memory. Also, it is recommended that you use the same memory type and speed for all DIMMs in the system. See Section 2.4 for memory details.
3. Check for bad DIMM modules or slots by swapping modules between slots and noting the results.
4. Check the power supply voltage 115V/230V switch.

Losing the System's Setup Configuration

1. Make sure that you are using a high quality power supply. A poor quality power supply may cause the system to lose the CMOS setup information. Refer to Section 1.5 for details on recommended power supplies.
2. The battery on your motherboard may be old. Check to verify that it still supplies ~3VDC. If it does not, replace it with a new one.
3. If the above steps do not fix the setup configuration problem, contact your vendor for repairs.

When the System Becomes Unstable

A. If the system becomes unstable during or after OS installation, check the following:

1. CPU/BIOS support: Make sure that your CPU is supported and that you have the latest BIOS installed in your system.
2. Memory support: Make sure that the memory modules are supported by testing the modules using memtest86 or a similar utility.



Note: Refer to the product page on our website at <http://www.supermicro.com> for memory and CPU support and updates.

3. HDD support: Make sure that all hard disk drives (HDDs) work properly. Replace the bad HDDs with good ones.
4. System cooling: Check the system cooling to make sure that all heatsink fans and CPU/system fans, etc., work properly. Check the hardware monitoring settings in the IPMI to make sure that the CPU and system temperatures are within the normal range. Also check the front panel Overheat LED and make sure that it is not on.
5. Adequate power supply: Make sure that the power supply provides adequate power to the system. Make sure that all power connectors are connected. Please refer to our website for more information on the minimum power requirements.
6. Proper software support: Make sure that the correct drivers are used.

B. If the system becomes unstable before or during OS installation, check the following:

1. Source of installation: Make sure that the devices used for installation are working properly, including boot devices such as CD/DVD and CD/DVD-ROM.
2. Cable connection: Check to make sure that all cables are connected and working properly.

3. Using the minimum configuration for troubleshooting: Remove all unnecessary components (starting with add-on cards first), and use the minimum configuration (but with a CPU and a memory module installed) to identify the trouble areas. Refer to the steps listed in Section A above for proper troubleshooting procedures.
4. Identifying bad components by isolating them: If necessary, remove a component in question from the chassis, and test it in isolation to make sure that it works properly. Replace a bad component with a good one.
5. Check and change one component at a time instead of changing several items at the same time. This will help isolate and identify the problem.
6. To find out if a component is good, swap this component with a new one to see if the system will work properly. If so, then the old component is bad. You can also install the component in question in another system. If the new system works, the component is good and the old system has problems.

3.2 Technical Support Procedures

Before contacting Technical Support, please take the following steps. Also, note that as a motherboard manufacturer, we do not sell directly to end-users, so it is best to first check with your distributor or reseller for troubleshooting services. They should know of any possible problem(s) with the specific system configuration that was sold to you.

1. Please review the 'Troubleshooting Procedures' and 'Frequently Asked Questions' (FAQs) sections in this chapter or see the FAQs on our website before contacting Technical Support.
2. BIOS upgrades can be downloaded from our website. **Note:** Not all BIOS can be flashed depending on the modifications to the boot block code.
3. If you still cannot resolve the problem, include the following information when contacting us for technical support:
 - Motherboard model and PCB revision number
 - BIOS release date/version (this can be seen on the initial display when your system first boots up)
 - System configuration

An example of a Technical Support form is posted on our website.

Distributors: For immediate assistance, please have your account number ready when contacting our technical support department by e-mail.

3.3 Frequently Asked Questions

Question: What type of memory does my motherboard support?

Answer: The motherboard supports up to 64 GB of DDR4 2133MHZ ECC UDIMM memory. See Section 2.4 for details on installing memory.

Question: How do I update my BIOS?

Answer: It is recommended that you **do not** upgrade your BIOS if you are not experiencing any problems with your system. Updated BIOS files are located on our website at <http://www.supermicro.com>. Please check our BIOS warning message and the information on how to update your BIOS on our website. Select your motherboard model and download the BIOS file to your computer. Also, check the current BIOS revision to make sure that it is newer than your BIOS before downloading. You can choose from the zip file and the .exe file. If you choose the zip BIOS file, please unzip the BIOS file onto a bootable USB device. Run the batch file using the format FLASH.BAT filename.rom from your bootable USB device to flash the BIOS. Then, your system will automatically reboot.

Question: Why can't I turn off the power using the momentary power on/off switch?

Answer: The instant power off function is controlled in BIOS by the Power Button Mode setting. When the On/Off feature is enabled, the motherboard will have instant off capabilities as long as the BIOS has control of the system. When the Standby or Suspend feature is enabled or when the BIOS is not in control such as during memory count (the first screen that appears when the system is turned on), the momentary on/off switch must be held for more than four seconds to shut down the system. This feature is required to implement the ACPI features on the motherboard.

3.4 Battery Removal and Installation

Battery Removal

To remove the onboard battery, follow the steps below:

1. Power off your system and unplug your power cable.
2. Locate the onboard battery as shown below.
3. Using a tool such as a pen or a small screwdriver, push the battery lock outwards to unlock it. Once unlocked, the battery will pop out from the holder.
4. Remove the battery.

Proper Battery Disposal

Please handle used batteries carefully. Do not damage the battery in any way; a damaged battery may release hazardous materials into the environment. Do not discard a used battery in the garbage or a public landfill. Please comply with the regulations set up by your local hazardous waste management agency to dispose of your used battery properly.

Battery Installation

1. To install an onboard battery, follow the steps 1 and 2 above and continue below:
2. Identify the battery's polarity. The positive (+) side should be facing up.
3. Insert the battery into the battery holder and push it down until you hear a click to ensure that the battery is securely locked.



Important: When replacing a battery, be sure to only replace it with the same type.

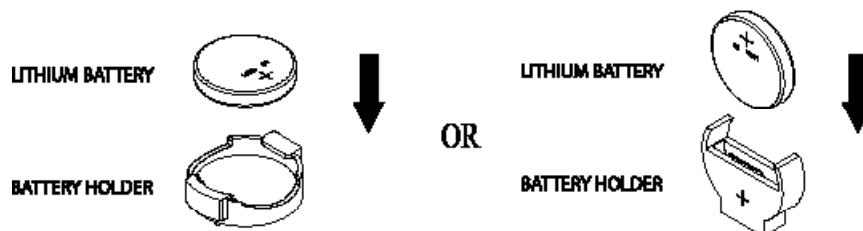

3.5 Returning Merchandise for Service

A receipt or copy of your invoice marked with the date of purchase is required before any warranty service will be rendered. You can obtain service by calling your vendor for a Returned Merchandise Authorization (RMA) number. When returning to the manufacturer, the RMA number should be prominently displayed on the outside of the shipping carton and mailed prepaid or hand-carried. Shipping and handling charges will be applied for all orders that must be mailed when service is complete.

For faster service, RMA authorizations may be requested online (<http://www.supermicro.com/support/rma/>).

This warranty only covers normal consumer use and does not cover damages incurred in shipping or from failure due to the alteration, misuse, abuse or improper maintenance of products.

During the warranty period, contact your distributor first for any product problems.

Chapter 4

BIOS

4.1 Introduction

This chapter describes the AMIBIOS™ Setup utility for the C7C232-CB-ML motherboards. The BIOS is stored on a chip and can be easily upgraded using a flash program.

 **Note:** Due to periodic changes to the BIOS, some settings may have been added or deleted and might not yet be recorded in this manual. Please refer to the Manual Download area of our website for any changes to BIOS that may not be reflected in this manual.

Starting the Setup Utility

To enter the BIOS Setup Utility, hit the <Delete> key while the system is booting-up. (In most cases, the <Delete> key is used to invoke the BIOS setup screen. There are a few cases when other keys are used, such as <F1>, <F2>, etc.) Each main BIOS menu option is described in this manual.

The Main BIOS screen has two main frames. The left frame displays all the options that can be configured. “Grayed-out” options cannot be configured. The right frame displays the key legend. Above the key legend is an area reserved for a text message. When an option is selected in the left frame, it is highlighted in white. Often a text message will accompany it. (Note that BIOS has default text messages built in. We retain the option to include, omit, or change any of these text messages.) Settings printed in **Bold** are the default values.

A " ►" indicates a submenu. Highlighting such an item and pressing the <Enter> key will open the list of settings within that submenu.

The BIOS setup utility uses a key-based navigation system called hot keys. Most of these hot keys (<F1>, <F2>, <F3>, <F4>, <Enter>, <ESC>, <Arrow> keys, etc.) can be used at any time during the setup navigation process.

4.2 Main Setup

When you first enter the AMI BIOS setup utility, you will enter the Main setup screen. You can always return to the Main setup screen by selecting the Main tab on the top of the screen. The Main BIOS setup screen is shown below. The following Main menu items will be displayed:



BIOS Information

BIOS Vendor

This item displays the name of the BIOS vendor.

Core Version

This item displays the version of the BIOS used in the system.

Compliancy

This item displays the UEFI and PI versions.

Project Version

This item displays the project version.

Build Date and Time

This item displays the build date and time of the BIOS.

Access Level

This item displays the access level security.

Processor Information

Name

This item displays the processor type.

Brand String

This item displays the processor version and speed.

Frequency

This item displays the processor frequency.

Processor ID

This item displays the processor ID number.

Stepping

This item displays the processor stepping information.

Number of Processors

This item displays the number of processor Core and thread.

Microcode Revision

This item displays the processor microcode revision.

Memory RC Version

This item displays the memory reference code revision.

Total Memory

This item displays the amount of system memory.

Memory Frequency

This item displays the memory frequency.

PCH Information

Name

This item displays the chipset type.

PCH SKU

This item displays the chipset name.

Stepping

This item displays the PCH stepping information.

LAN PHY Revision

This item displays the LAN chipset revision.

ME Firmware Revision

This item displays the Management Engine firmware revision.

ME Firmware SKU

This item displays the Management Engine firmware SKU.

System Language

This item displays the language.

System Date

This item displays the system date

System Time

This item displays the system time. The time is in the 24-hour format. For example, 5:30 P.M. appears as 17:30.

4.3 Advanced Setup Configurations

Use the arrow keys to select Advanced setup and press <Enter> to access the submenu items:

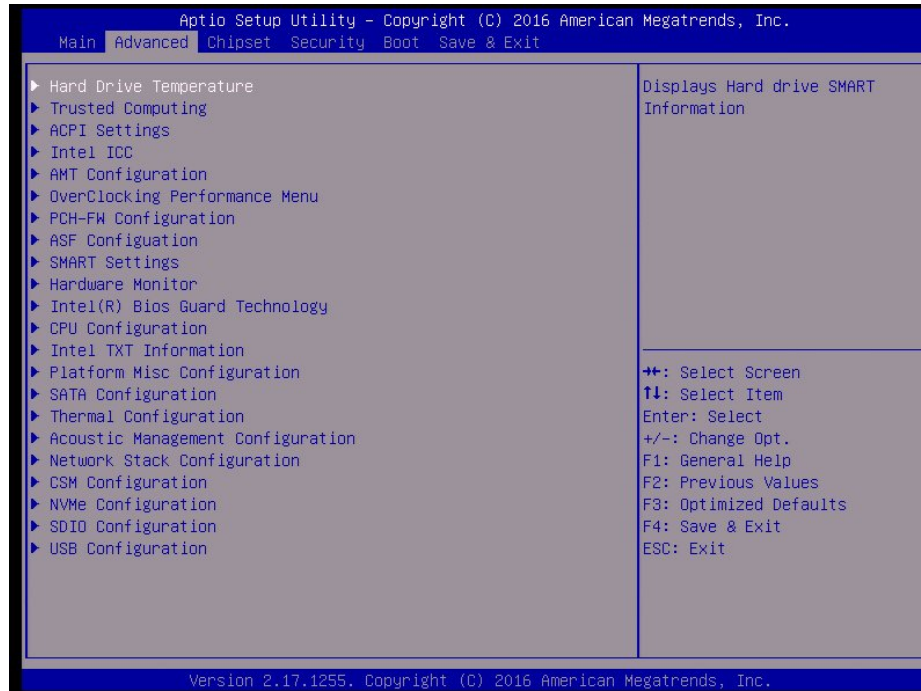

Warning: Take Caution when changing the Advanced settings. An incorrect value, a very high DRAM frequency or an incorrect BIOS timing setting may cause the system to malfunction. When this occurs, restore the setting to the manufacture default setting.

► Hard Drive Temperatures

This feature displays the hard drive SMART information such as the temperature.

► Trusted Computing (Available when TPM is supported)

Configuration

Security Device Support

If this feature and the TPM jumper on the motherboard are both set to Enabled, onboard security devices will be enabled for TPM (Trusted Platform Module) support to enhance data integrity and network security. Please reboot the system for a change on this setting to take effect. The options are Disable and **Enable**.

TPM State

This feature changes the TPM State. The options are **Disabled** and Enabled. **Note:** The system will restart to change the TPM State.

Pending operation

Use this item to schedule a TPM-related operation to be performed by a security device for system data integrity. Your system will reboot to carry out a pending TPM operation. The options are **None** and TPM Clear.

Device Select

Use this feature to select the TPM version. TPM 1.2 will restrict support to TPM 1.2 devices. TPM 2.0 will restrict support for TPM 2.0 devices. Select Auto to enable support for both versions. The default setting is **Auto**.

The following are informational status messages that indicate the current TPM State:

TPM Enabled Status

TPM Active Status

TPM Owner Status

▶ACPI Settings

Enable ACPI Auto Configuration

Use this feature to enable or disable the ACPI auto configuration. If Disabled is selected, the five features below are available for configuration. The options are **Disabled** and Enabled.

Enable Hibernation

Use this feature to enable or disable the system's ability to hibernate. The options are Disabled and **Enabled**.

ACPI Sleep State

This feature selects the ACPI Sleep State that the system will enter into when the suspend button is activated. The options are Suspend Disabled and **S3 (Suspend to RAM)**.

Lock Legacy Resources

Use this feature to enable or disable Lock of Legacy Resources. The options are **Disabled** and Enabled.

S3 Video Repost

Enable this feature for the video to resume after waking up from an S3 sleep. The options are **Disabled** and Enabled.

ACPI Low Power S0 Idle

Enable this feature for hardware components that are not in use to enter a low power state. The options are **Disabled** and Enabled.

► Intel ICC (Integrated Clock Control)

ICC/OC Watchdog Timer

If Enabled, the ICC Watchdog Timer will be exposed to the operating system as an ACPI device. The options are **Disabled** and Enabled.

ICC Locks after EOP

Use this feature to specify the ICC registers that can be written after the End of Post (EOP). Select Default for the registers to be left writeable. Select All Locked for no register adjustments after EOP. Select All Unlocked for register adjustments after EOP. The options are **Default**, All Locked, and All Unlocked.

The following information will display:

- Default Clock Settings
- Frequency Range Limits
- Maximum Spread %
- Spread Mode Adjustments

► AMT Configuration

Intel AMT

Select Enabled to use Intel AMT (Active Management Technology) to enhance system performance. This feature controls the BIOS extension execution. The options are Disabled and **Enabled**.

BIOS Hotkey Pressed

Select Enabled to use the BIOS Hotkey feature to enter the Active Management Technology setup after POST. The options are **Disabled** and Enabled.

MEBx Selection Screen

Use this feature to enable or disable the Management Engine BIOS Extension screen. Use this extension to configure AMT devices on the system. The options are **Disabled** and Enabled.

Hide Un-Configure ME Confirmation Prompt

Use this feature to hide the un-configure the Management Engine without a password confirmation prompt. The options are **Disabled** and Enabled.

MEBx Debug Message Output

Use this feature to enable or disable MEBx debug message output. The options are **Disabled** and Enabled.

Un-Configure ME

Use this feature to enable or disable unconfigure ME without password. The options are **Disabled** and Enabled.

Amt Wait Timer

Use this feature to set the timer to wait before sending ASF_GET_BOOT_OPTIONS. Use the "-" or "+" keys to select a value.

ASF

Use this feature to enable or disable Alert Specification Format (ASF). ASF provides alerts on BIOS and system health information. The options are Disabled and **Enabled**.

Activate Remote Assistance Process

Use this feature to enable or disable trigger Client Initiated Remote Access (CIRA) boot. The options are **Disabled** and Enabled.

USB Provisioning of AMT

Use this feature to enable or disable USB Provisioning of AMT. The options are Disabled and **Enabled**.

PET Progress

Use this feature to enable or disable Platform Event Trap (PET) events progress to receive PET events or not. Enable this feature to receive warning of possible system failures. The options are Disabled and **Enabled**.

AMT CIRA Timeout

This item displays the CIRA timeout value.

WatchDog

Select Enabled to allow AMT to reset or power down the system if the operating system or BIOS hangs or crashes. The options are **Disabled** and Enabled.

OS Timer / BIOS Timer

These options appear if WatchDog (above) is enabled. This is a timed delay in seconds, before a system power down or reset after a BIOS or operating system failure is detected. Directly enter the value in seconds.

► OverClocking Performance Menu

OverClocking Feature

Use this feature to enable or disable processor and memory overclocking. The options are **Disabled** and **Enabled**.

RSR

Use this feature to enable or disable the Reliability Stress Restrictor (RSR) feature. The options are **Disabled** and **Enabled**.

► PCH-FW Configuration

The following firmware information will display:

- ME FW Version
- ME Firmware Mode
- ME Firmware Type
- ME Firmware SKU
- PTT Capability / State
- NFC Support

ME Unconfig on RTC Clear State

If **Disabled**, this feature will cause ME to not unconfigure on RTC clear. The options are **Enabled** and **Disabled**.

► Firmware Update Configuration

Me FW Image Re-Flash

Use this feature to update the Management Engine firmware. The options are **Enabled** and **Disabled**.

► ASF Configuration

ASF Support

Use this feature to disable or enable Alert Standard Format (ASF). ASF provides alerts on BIOS and system health information. The options are **Disabled** and **Enabled**.

ASF BIOS Mode

Enable this feature for BIOS alerts. The options are **OFF**, **ON**, and **Alert Only**.

ASF WatchDog Timer

Use this feature to disable or enable the Watch Dog timer. The options are **Disabled** and **Enabled**.

The following information will display:

- WatchDog Timer: BIOS
- WatchDog Timer: OS

►SMART Settings

SMART Self Test

Enable this feature to allow Self Monitoring Analysis and Reporting Technology (SMART) self test on all hard disk drives during POST. The options are **Disabled** and **Enabled**.

►Hardware Monitor

Pc Health Status

The following information will display:

- System temperature
- PCH temperature
- CPU temperature
- CPU Fan Speed
- System Fan Speed
- VCC_CORE
- VDDQ
- 12V_S0
- +5V_AUX1
- 3.3V_S0
- 5V_S0

► Intel® Bios Guard Technology

Intel Bios Guard Support

Select Enabled to prevent unauthorized software access and to add hardware protection. The options are **Disabled** and Enabled.

► CPU Configuration

The following CPU information will display:

- CPU Type
- CPU Signature
- Microcode Patch
- Max CPU Speed
- Min CPU Speed
- CPU Speed
- Processor Cores
- Hyper Threading Technology
- Intel VT-x Technology
- Intel SMX Technology
- 64-bit
- EIST Technology
- CPU C3 state
- CPU C6 state
- CPU C7 state
- CPU C8 state
- CPU C9 state
- CPU C10 state
- L1 Data Cache
- L1 Code Cache

- L2 Cache
- L3 Cache
- L4 Cache

Hyper-threading (Available when supported by the CPU)

Select Enabled to support Intel Hyper-threading Technology to enhance CPU performance. The options are **Enabled** and Disabled.

Active Processor Cores

This feature determines how many CPU cores will be activated for each CPU. When all is selected, all cores in the CPU will be activated. (Please refer to Intel's website for more information.) The options are **All** and 1, 2, and 3.

Intel® Virtualization Technology

Select Enable to use Intel Virtualization Technology so that I/O device assignments will be reported directly to the VMM (Virtual Memory Management) through the DMAR ACPI Tables. This feature offers fully-protected I/O resource-sharing across the Intel platforms, providing the user with greater reliability, security and availability in networking and data-sharing. The settings are Disabled and **Enabled**.

Hardware Prefetcher (Available when supported by the CPU)

If set to Enabled, the hardware prefetcher will prefetch streams of data and instructions from the main memory to the L2 cache to improve CPU performance. The options are Disabled and **Enabled**.

Adjacent Cache Line Prefetch (Available when supported by the CPU)

The CPU prefetches the cache line for 64 bytes if this feature is set to Disabled. The CPU prefetches both cache lines for 128 bytes as comprised if this feature is set to **Enabled**.

CPU AES

Select Enabled to enable Intel CPU Advanced Encryption Standard (AES) Instructions for CPU to enhance data integrity. The options are **Disabled** and Enabled.

Intel® Speed Shift Technology

Select Enabled to support Intel's Speed Shift Technology, which allows the user to control the processor's frequency and voltage through the operating system. This feature is supported on Windows 10. The options are Disabled and **Enabled**.

Intel® SpeedStep™

Intel SpeedStep Technology allows the system to automatically adjust processor voltage and core frequency to reduce power consumption and heat dissipation. The options are Disabled and **Enabled**.

Power Limit 1 Override

Select Enabled to support average power limit (PL1) override. The default setting is **Disabled**.

****If the item above is set to Enabled, the next two items will be available for user configuration:***

Power Limit 1

Use this item to configure the value for Power Limit 1. The value is in milli watts and the step size is 125mW. Use the number keys on the keyboard to enter the value. Enter 0 to use the manufacture default setting.

Power Limit 1 Window

Use this feature to indicate the time window over which the TDP value should be maintained. The default value is 0. The options are **0**, 1, 2, 3, 4, 5, 6, 7, 8, 10, 12, 14, 16, 20, 24, 28, 32, 40, 48, 56, 64, 80, 96, 112, and 128.

Power Limit 2 Override

Select Enabled to support rapid power limit (PL2) override. The default setting is **Enabled**.

Power Limit 2

Use this item to configure the value for Power Limit 2. The value is in milliwatts and the step size is 125mW. Use the number keys on the keyboard to enter the value. Enter 0 to use the manufacture default setting. If the value is 0, the BIOS will set PL2 as 1.25* TDP.

1-Core Ratio Limit Override

This increases (multiplies) 1 clock speed in the CPU core in relation to the bus speed when one CPU core is active. Use the "+" or "-" keys to set the value. Enter 0 to use the manufacture default setting.

2-Core Ratio Limit Override

This increases (multiplies) 2 clock speeds in the CPU core in relation to the bus speed when two CPU cores are active. Use the "+" or "-" keys to set the value. Enter 0 to use the manufacture default setting.

Platform PL1 Enable

Use this feature to enable or disable Platform Power Limit 1 programming. If this feature is enabled, it activates the PL1 value to be used by the processor to limit the average power of given time window. The options are **Disabled** and Enabled.

Platform PL2 Enable

Use this feature to enable or disable Platform Power Limit 2 programming. If this feature is enabled, it activates the PL2 value to be used by the processor to limit the average power of given time window. The options are **Disabled** and Enabled.

CPU C states

Use this feature to enable the C-State of the CPU. The options are Disabled and **Enabled**.

Enhanced C-states

Use this feature to enable the enhanced C-State of the CPU. The options are Disabled and **Enabled**.

C-State Auto Demotion

Use this feature to prevent unnecessary excursions into the C-states to improve latency. The options are Disabled, C1, C3, and **C1 and C3**.

C-State Un-demotion

This feature allows the user to enable or disable the un-demotion of C-State. The options are Disabled, C1, C3, and **C1 and C3**.

Package C state demotion

Use this feature to enable or disable the Package C-State demotion. The options are Disabled and **Enabled**.

Package C state undemotion

Use this feature to enable or disable the Package C-State un-demotion. The options are Disabled and **Enabled**.

CState Pre-Wake

This feature allows the user to enable or disable the C-State Pre-Wake. The options are Disabled and **Enabled**.

Package C State Limit

Use this feature to set the Package C-State limit. The options are C0/C1, C2, C3, C6, C7, C7s, C8, and **AUTO**.

► CPU Thermal Configuration**CPU DTS**

Select Enabled for the ACPI thermal management to use the DTS SMM mechanism to obtain CPU temperature values. Select Disabled for EC to report the CPU temperature values. The options are **Disabled** and Enabled.

TCC Activation Offset

Use this feature to select the offset value from the factory Thermal Control Circuit (TCC) activation temperature. A higher offset value will activate the TCC sooner. Use the "+" or "-" keys to set the value.

ACPI 3.0 T-States

Select Enabled to support CPU throttling by the operating system to reduce power consumption. The options are Enabled and **Disabled**.

Intel TXT (LT) Support

Intel TXT (Trusted Execution Technology) helps protect against software-based attacks and ensures protection, confidentiality and integrity of data stored or created on the system. Use this feature to enable or disable TXT Support. The options are **Disabled** and Enabled.

SW Guard Extensions (SGX)

Use this feature to enable or disable the Intel Software Guard Extensions (SGX). SGX is a set of CPU instructions that increases software security. The options are Disabled, **Enabled**, and Software Controlled.

Select Owner EPOCH input type

Use this feature to select an Intel Software Guard Extensions (SGX) EPOCH mode. Each mode has different values, which can be entered manually. The options are **No Change in Owner EPOCHs**, Change to New Random Owner EPOCHs, and Manual User Defined Owner EPOCHs.

PRMRR Size

The BIOS must reserve a contiguous region of Processor Reserved Memory (PRM) in the Processor Reserved Memory Range Register (PRMRR). The options are **Auto**, 32MB, 64MB, and 128MB.

► Intel TXT Information

The following Intel TXT information will display:

- Chipset
- BiosAcm
- Chipset Txt
- Cpu Txt
- Error Code
 - Class Code
 - Major Code
 - Minor Code

► Platform Misc Configuration

► Platform Setting

Pmic Vcc IO Level

Use this feature to select the Pmic Vcc IO voltage level. The options are **Disabled**, 1.05V, 1.071V, 1.023V, 0.997V, 0.850V, 0.900V, and 0.950V.

Pmic Vddq Level

Use this feature to select the Pmic Vddq voltage level. The options are **Disabled**, 0, 1, 2, 3, 4, 5, 6, and 7.

Select Camera

Use this feature to select the type of camera that is connected to the system. The options are **IVCAM** and DS4.

Enable 3D Camera DFU device

Use this feature to enable or disable the Bell Cliffs 3D Imaging Camera DFU (Device Firmware Update). The options are **Disabled** and Enabled.

HID Event Filter Driver

Use this feature to enable or disable the HID (Human Interface Device) Event Filter Drivers. The options are **Disabled** and Enabled.

Enable Wireless Charge Support

Use this feature to enable or disable wireless charging support. The options are **Disabled** and Enabled.

Enable FFU Support

Use this feature to enable or disable FFU (Full Flash Update) support. FFU can capture hard drive information, including partitions. The options are **Disabled** and Enabled.

► SATA Configuration

When this submenu is selected, the AMI BIOS automatically detects the presence of the SATA devices that are supported by the Intel PCH chip and displays the following items:

SATA Controller(s)

This item enables or disables the onboard SATA controller supported by the Intel PCH chip. The options are **Enabled** and Disabled.

SATA Mode Selection

Use this item to select the mode for the installed SATA drives. The options are **AHCI** and RAID.

SATA Test Mode

Use this item to disable or enable the SATA testing mode. The options are Enabled and **Disabled**.

**If this item is set to Disabled, then Software Feature Mask Configuration and Aggressive LPM Support are available for configuration.*

► Software Feature Mask Configuration**RAID0**

Use this item to disable or enable RAID0 support. The options are Disabled and **Enabled**.

RAID1

Use this item to disable or enable RAID1 support. The options are Disabled and **Enabled**.

RAID10

Use this item to disable or enable RAID10 support. The options are Disabled and **Enabled**.

RAID5

Use this item to disable or enable RAID5 support. The options are Disabled and **Enabled**.

Intel Rapid Recovery Technology

Use this item to disable or enable Intel Rapid Recovery Technology support. The options are Disabled and **Enabled**.

OROM UI and Banner

Select Enabled for RAID information to display during the POST. The options are Disabled and **Enabled**.

HDD Unlock

Select Enabled to enable the HDD password unlock. The options are Disabled and **Enabled**.

LED Locate

If Enabled, this feature provides an indication that the LED/SGPIO hardware is attached. The options are Disabled and **Enabled**.

IRRT Only on eSATA

The IRRT (Intel Rapid Recovery Technology) feature is part the Intel Rapid Stroage Technology. If this feature is enabled, it mirrors data from a primary hard drive to a recovery drive. The options are Disabled and **Enabled**.

Smart Reponse Technology

Use this item to disable or enable Smart Resonse Technology. The options are **Disabled** and Enabled.

OROM UI Normal Delay

Use this item to select the delay time of the OROM UI splash screen. The options are 2 Seconds, **4 Seconds**, 6 Seconds, and 8 Seconds.

RST Force Form

Use this item to enable or disable Intel Rapid Storage Technology. The options are **Disabled** and Enabled.

Aggressive LPM Support

When this item is set to Enabled, the SATA AHCI controller manages the power usage of the SATA link. The controller will put the link in a low power mode during extended periods of I/O inactivity, and will return the link to an active state when I/O activity resumes. The options are Enabled and **Disabled**.

Serial ATA Port 0 ~ Port 5

This item displays the information detected on the installed SATA drive on the particular SATA port.

- Software Preserve

Port 0 ~ Port 5

Use this item to enable or disable the designated SATA port. The options are Disabled and **Enabled**.

Hot Plug

This feature designates the SATA port specified for hot plugging. Set this item to Enabled for hot-plugging support, which will allow the user to replace a SATA disk drive without shutting down the system. The options are **Disabled** and Enabled.

External SATA

Use this feature to disable or enable external SATA support. The options are **Disabled** and Enabled.

Spin Up Device

On an edge detect from 0 to 1, set this item to allow the PCH to start a COMRESET initialization to the device. The options are **Disabled** and Enabled.

SATA Device Type

Use this item to specify if the sSATA port specified by the user should be connected to a Solid State drive or a Hard Disk Drive. The options are **Hard Disk Drive** and Solid State Drive.

Topology

Use this feature to configure the SATA Topology. The options are **Unknown**, ISATA, Direct Connect, Flex, and M2.

► Thermal Configuration**► Platform Thermal Configuration****Automatic Thermal Reporting**

Set this feature to Enabled for automatic thermal reporting. Set to Disabled to manually configure the thermal reporting.

****If this feature is set to Disabled, Critical Trip Point is available for configuration:***

Critical Trip Point

Use this feature to set the value that controls the temperature of the ACPI Critical Trip Point. The options are 15 C, 23 C, 31 C, 39 C, 47 C, 55 C, 63 C, 71 C, 79 C, 87 C, 95 C, 100 C, 103 C, 111 C, **119 C (POR)**, and 127 C.

Active Trip Point 0

Use this feature to set the temperature of the ACPI Active Trip Point 0 that turns on the processor fan. The options are Disabled, 15 C, 23 C, 31 C, 39 C, 47 C, 55 C, 63 C, **71 C**, 79 C, 87 C, 95 C, 103 C, 111 C, and 119 C (POR).

Active Trip Point 0 Fan Speed

Use this feature to set the fan speed in percentage. The value is from 0 to 100. Use the "+" or "-" keys to set the value.

Active Trip Point 1

Use this feature to set the temperature of the ACPI Active Trip Point 1 that turns on the processor fan. The options are Disabled, 15 C, 23 C, 31 C, 39 C, 47 C, **55 C**, 63 C, 71 C, 79 C, 87 C, 95 C, 103 C, 111 C, and 119 C (POR).

Active Trip Point 1 Fan Speed

Use this feature to set the fan speed in percentage. This value must be less than the Active Trip Point 0 Fan Speed. The value is from 0 to 100. Use the "+" or "-" keys to set the value.

Passive Trip Point

Use this feature to set the value that controls the temperature of the ACPI Passive Trip Point. This is the point in which the operating system begins to throttle the processor. The options are Disabled, 15 C, 23 C, 31 C, 39 C, 47 C, 55 C, 63 C, 71 C, 79 C, 87 C, **95 C**, 103 C, 111 C, and 119 C (POR).

Passive TC1 Value

Use this feature to set the TC1 value for the ACPI passive cooling formula. The value is from 1 to 16. Use the "+" or the "-" keys to set the value.

Passive TC2 Value

Use this feature to set the TC2 value for the ACPI passive cooling formula. The value is from 1 to 16. Use the "+" or the "-" keys to set the value.

Passive TSP Value

Use this feature to specify how often the OS should read the temperature. Values are in one tenths of a second. The values are from 2 to 32. Use the "+" or the "-" keys to set the value.

►Acoustic Management Configuration

This section displays the acoustic management feature of a detected hard disk drive. The user can modify the access pattern, change default mode to quiet mode, or the power mode to consume as little power as possible.

► Network Stack Configuration

Network Stack

Select Enabled to enable UEFI (Unified Extensible Firmware Interface) for network stack support. The options are **Disabled** and Enabled.

**If Network Stack is Enabled, the four items below are available for configuration:*

IPv4 PXE Support

Select Enabled to enable IPv4 PXE boot support. The options are **Enabled** and Disabled.

IPv6 PXE Support

Select Enabled to enable IPv6 PXE boot support. The options are **Enabled** and Disabled.

PXE boot wait time

Use this option to specify the wait time to press the ESC key to abort the PXE boot. Use the "+" or "-" keys to set the value. The default setting is **0**.

Media detect count

Use this option to specify the number of times media will be checked. Use the "+" or "-" keys to set the value. The default setting is **1**.

► CSM Configuration

CSM Support

Select Enabled to support the EFI Compatibility Support Module (CSM), which provides compatibility support for traditional legacy BIOS for system boot. The options are **Enabled** and Disabled.

CSM 16 Module Version

This feature displays the version number.

Option ROM Messages

Use this feature to set the display mode for the Option ROM. Select Keep Current to display the current AddOn ROM setting. Select Force BIOS to use the Option ROM display set by the system BIOS. The options are **Force BIOS** and Keep Current.

INT19 Trap Response

Interrupt 19 is the software interrupt that handles the boot disk function. When this item is set to Immediate, the ROM BIOS of the host adaptors will "capture" Interrupt 19 at bootup immediately and allow the drives that are attached to these host adaptors to function as bootable disks. If this item is set to Postponed, the ROM BIOS of the host adaptors will not capture Interrupt 19 immediately and allow the drives attached to these adaptors to function as bootable devices at bootup. The options are **Immediate** and Postponed.

Boot option filter

This option prioritizes the order of bootable devices that the system to boot from. The options are **UEFI and Legacy**, Legacy only, and UEFI only.

Option ROM execution**Network**

Use this item to select the network Option ROM type. The options are Do Not Launch, UEFI, and **Legacy**.

Storage

Use this item to select the storage Option ROM type. The options are Do Not Launch, UEFI, and **Legacy**.

Video

Use this item to select the video Option ROM type. The options are Do Not Launch, UEFI, and **Legacy**.

Other PCI devices

Use this item to select the PCI devices Option ROM type. The options are Do Not Launch, **UEFI**, and Legacy.

► NVMe Configuration

This feature displays the information of NVMe devices that are detected.

► SDIO Configuration**SDIO Access Mode**

Select Auto to access SD devices in DMA mode. The options are **Auto**, ADMA, SDMA, and PIO.

► USB Configuration

The following USB information will display:

- USB Module Version
- USB Controllers
- USB Devices

Legacy USB Support

This feature enables support for legacy USB devices. Select Auto to disable legacy support if USB devices are not present. Select Disable to have USB devices available only for EFI applications. The options are **Enabled**, Disabled, and Auto.

XHCI Hand-off

This is a work-around solution for operating systems that do not support XHCI (Extensible Host Controller Interface) hand-off. The XHCI ownership change should be claimed by the XHCI driver. The settings are Enabled and **Disabled**.

USB Mass Storage Driver Support

Set Enabled to enable USB mass storage driver support. The options are Disabled and **Enabled**.

Port 60/64 Emulation

This feature enables or disables I/O port 60h/64h emulation support. This should be enabled for complete USB keyboard legacy support for non-USB-aware Operating Systems. The options are **Disabled** and Enabled.

USB hardware delays and time-outs:**Device power-up delay**

Use this feature to set the maximum time the device will take before it properly reports itself to the Host Controller. Set to Auto for the default value. The options are **Auto** and Manual.

4.4 Chipset

Use this feature to configure Chipset settings.



► System Agent (SA) Configuration

The following System Agent information will display:

- System Agent Bridge Name
- SA PCIe Code Version
- VT-d

VT-d

Select Enabled to enable Intel Virtualization Technology support for Direct I/O VT-d by reporting the I/O device assignments to VMM through the DMAR ACPI Tables. This feature offers fully-protected I/O resource-sharing across the Intel platforms, providing the user with greater reliability, security and availability in networking and data sharing. The options are **Enabled** and Disabled.

► Graphics Configuration

Primary Display

Use this feature to select the graphics device to be used as the primary display. The options are **Auto**, PEG, and PCIE.

Primary PEG

This feature allows the user to select the primary PCI Express Graphics (PEG) slot. The options are **Auto**, PEG11, and PEG12.

Primary PCIE (PCI-Express Graphics)

This feature allows the user to specify which graphics card to be used as the primary graphics card. The options are **Auto**, PEG1, PEG2, PEG3, PEG4, PEG5, PEG6, PEG7, PEG8, PEG9, PEG10, PEG11, PEG12, PEG13, PEG14, PEG15, PEG16, PEG17, PEG18, and PEG19.

► DMI/OPI Configuration

The following DMI information will display:

- DMI

DMI Vc1 Control

Use this feature to enable or disable DMI Virtual Channel 1. The options are Enabled and **Disabled**.

DMI Vcm Control

Use this feature to enable or disable the DMI Virtual Channel map. The options are **Enabled** and Disabled.

Program Static Phase1 Eq

Use this feature to configure the De-emphasis control on DMI. The options are Disabled and **Enabled**.

DMI Link ASPM Control

Use this feature to set the ASPM (Active State Power Management) state on the SA (System Agent) side of the DMI Link. The options are Disabled and **L1**.

DMI Extended Sync Control

Use this feature to enable or disable the DMI extended synchronization. The options are Enabled and **Disabled**.

DMI De-emphasis Control

Use this feature to configure the De-emphasis control on DMI. The options are -6 dB and -3.5 dB.

► PEG Port Configuration**PEG 0:1:0****Enable Root Port**

Use this feature to enable or disable the PCI Express Graphics (PEG) device in the port specified by the user. The options are Disabled, Enabled, and **Auto**.

Max Link Speed

Use this item to configure the link speed of a PCI-E port specified by the user. The options are **Auto**, Gen1, Gen2, and Gen3.

ASPM

Use this item to set the Active State Power Management (ASPM) level for a PEG0. Select Auto for the system BIOS to automatically set the ASPM level based on the system configuration. Select Disabled to disable ASPM support. The options are **Disabled**, Auto, ASPM L0s, ASPM L1, ASPM L0sL1.

PEG0 Slot Power Limit Value

Use this feature to set the upper limit on the power supplied by the PCIE slot. Press "+" or "-" on the keyboard to change this value. The default setting is **75**.

PEG0 Slot Power Limit Scale

Use this feature to select the scale used for the slot power limit value. The options are **1.0x**, 0.1x, 0.01x, and 0.001x.

PEG 0:1:1**Enable Root Port**

Use this feature to enable or disable the PCI Express Graphics (PEG) device in the port specified by the user. The options are Disabled, Enabled, and **Auto**.

Max Link Speed

Use this item to configure the link speed of a PCI-E port specified by the user. The options are **Auto**, Gen1, Gen2, and Gen3.

PEG1 Slot Power Limit Value

Use this feature to set the upper limit on the power supplied by the PCIE slot. Press "+" or "-" on the keyboard to change this value. The default setting is **75**.

PEG1 Slot Power Limit Scale

Use this feature to select the scale used for the slot power limit value. The options are **1.0x**, 0.1x, 0.01x, and 0.001x.

PEG 0:1:2**Enable Root Port**

Use this feature to enable or disable the PCI Express Graphics (PEG) device in the port specified by the user. The options are Disabled, Enabled, and **Auto**.

Max Link Speed

Use this item to configure the link speed of a PCI-E port specified by the user. The options are **Auto**, Gen1, Gen2, and Gen3.

PEG2 Slot Power Limit Value

Use this feature to set the upper limit on the power supplied by the PCIE slot. Press "+" or "-" on the keyboard to change this value. The default setting is **75**.

PEG2 Slot Power Limit Scale

Use this feature to select the scale used for the slot power limit value. The options are **1.0x**, 0.1x, 0.01x, and 0.001x.

PEG0 Max Payload size

Use this feature to select the PEG0 max payload size. The options are **Auto**, 128TLP, and 256TLP.

Detect Non-Compliance Device

Select Enabled for the AMI BIOS to automatically detect a PCI-E device that is not compliant with the PCI-E standards. The options are **Disabled** and Enabled.

Program PCIe ASPM after OpROM

PCIe ASPM, the Active State Power Management for PCI-Express slots, is a power management protocol used to manage power consumption of serial-link devices installed on PCI-Exp slots during a prolonged off-peak time. If this item is set to Enabled, PCI-E ASPM will be programmed after OPROM. If this item is set to Disabled, the PCI-E ASPM will be programmed before OPROM. The options are **Disabled** and Enabled.

►Memory Configuration

The following memory information will display:

- Memory RC Version
- Memory Frequency

- Total Memory
- VDD
- DIMMA1
- DIMMA2
- DIMMB1
- DIMMB2
- Memory Timings (tCL-tRCD-tRP-tRAS)

Maximum Memory Frequency

Use this feature to set the maximum memory frequency for onboard memory modules. The options are **Auto**, 1067, 1333, 1600, 1867, 2133, 2400, 2667, 2933, and 3200.

Max TOLUD

This feature sets the maximum TOLUD value, which specifies the "Top of Low Usable DRAM" memory space to be used by internal graphics devices, GTT Stolen Memory, and TSEG, respectively, if these devices are enabled. The options are **Dynamic**, 1 GB, 1.25 GB, 1.5 GB, 1.75 GB, 2 GB, 2.25 GB, 2.5 GB, 2.75 GB, 3 GB, 3.25 GB, and 3.5 GB.

Energy Performance Gain

Use this feature to enable or disable the energy performance gain. The options are **Disabled** and **Enabled**.

The following memory information will display:

- EPG DIMM Idd3N
- EPG DIMM Idd3P

Memory Scrambler

Select **Enabled** to enable memory scrambler support. The options are **Disabled** and **Enabled**.

Channel A DIMM Control

Use this feature to enable or disable the DIMMs on channel A. The options are **Enable both DIMMs**, **Disable DIMMA1**, **Disable DIMMA2**, and **Disable both DIMMs**.

Channel B DIMM Control

Use this feature to enable or disable the DIMMs on channel A. The options are **Enable both DIMMs**, **Disable DIMMB1**, **Disable DIMMB2**, and **Disable both DIMMs**.

Force Single Rank

Set this feature to Enabled for Rank 0 to be used for each DIMM module. The options are **Disabled** and Enabled.

Time Measure

Use this feature to enable or disable the printing of the time it takes to execute the memory reference code (MRC). The MRC ensures that the RAM is functioning properly. The options are **Disabled** and Enabled.

► Memory Thermal Configuration**► Memory Power and Thermal Throttling****DDR PowerDown and idle counter**

Use this feature to enable or disable the PCI Express Graphics (PEG) device in the port specified by the user. The options are PCODE and **BIOS**.

REFRESH_2X_MODE

Use this feature to select the refresh mode. The options are **Disabled**, 1-Enabled for WARM or HOT, and 2-Enabled HOT only.

► Dram Power Meter

The following memory information will display:

- Energy Scale Factor
- Idle Energy DIMMA1
- PowerDown Energy DIMMA1
- Activate Energy DIMMA1
- Read Energy DIMMA1
- Write Energy DIMMA1
- Idle Energy DIMMA2
- PowerDown Energy DIMMA2
- Activate Energy DIMMA2
- Read Energy DIMMA2

- Write Energy DIMMA2
- Idle Energy DIMMB1
- PowerDown Energy DIMMB1
- Activate Energy DIMMB1
- Read Energy DIMMB1
- Write Energy DIMMB1
- Idle Energy DIMMB2
- PowerDown Energy DIMMB2
- Activate Energy DIMMB2
- Read Energy DIMMB2
- Write Energy DIMMB2

► Memory Thermal Reporting

Lock Thermal Management Registers

Select Enabled to lock the PCU registers related to DDR power and thermal management. The options are Disabled and **Enabled**.

Memory Thermal Reporting

Closed Loop Therm Manage

Use this feature to monitor the power consumption and temperature of the system to predict a thermal trend. The options are **Disabled** and Enabled.

► Memory RAPL

The following memory information will display:

- Rapl Power Floor Ch0
- Rapl Power Floor Ch1

RAPL PL Lock

Select Enabled to lock the PCU registers related to DDR power and thermal management. The options are **Disabled** and Enabled.

► PCH-IO Configuration

The following PCH-IO information will display:

- Intel PCH RC Version
- Intel PCH SKU Name
- Intel PCH Rev ID

► PCI Express Configuration

DMI Link ASPM Control

Use this feature to set the ASPM (Active State Power Management) state on the SA (System Agent) side of the DMI Link. The options are Disabled and **Enabled**.

Peer Memory Write Enable

Use this feature to enable or disable peer memory write. The options are **Disabled** or Enabled.

► PCI Express Root Port 1 ~ 4, 6 ~ 20

**PCIe Port 5 is assigned to LAN*

ASPM Support

Use this item to set the Active State Power Management (ASPM) level for a PCI-E device. Select Auto for the system BIOS to automatically set the ASPM level based on the system configuration. Select Disabled to disable ASPM support. The options are **Disabled**, L0s, L1, L0s & L1, and Auto.

L1 Substates

Use this feature to set the PCI Express L1 Substates. The options are Disabled, L1.1, L1.2, and **L1.1 & L1.2**.

PCIe Speed

Use this feature to select the PCI Express port speed. The options are **Auto**, Gen1, Gen2, and Gen3.

Detect Non-Compliance Device

Select Enabled for the AMI BIOS to automatically detect a PCI-E device that is not compliant with the PCI-E standards. The options are **Disabled** and Enabled.

PCIE LTR

Use this feature to enable or disable PCIE latency reporting. The options are Disabled and **Enabled**.

► USB Configuration

USB SS Physical Connector #0 ~ #9

Use this feature to enable or disable the designated USB SuperSpeed port. The options are Disabled or **Enabled**.

USB HS Physical Connector #0 ~ #13

Use this feature to enable or disable the designated USB HighSpeed port. The options are Disabled or **Enabled**.

► HD Audio Configuration

HD Audio

Use this feature to control the detection of an HD audio device. The options are Disabled, Enabled, and **Auto**.

Audio DSP

Use this feature to enable or disable the Audio Digital Signal Processor (DSP). The options are **Disabled** and Enabled.

HDA-Link Codec Select

Use this feature to select which audio codec to use. The options are **Platform Onboard** and External Kit.

iDisplay Audio Disconnect

Use this feature to enable or disable the iDisplay Audio Codec. The options are **Disabled** and Enabled.

► HD Audio Advanced Configuration

HD Audio Subsystem Advanced Configuration Settings

I/O Buffer Control:

I/O Buffer Ownership

Use this feature to select the ownership of the I/O buffer. The options are **HD-Audio Link**, HD-Audio Link / I2S Port, and I2S Port.

I/O Buffer Voltage Select

Use this feature to select the voltage for the I/O buffer. The options are **3.3V** and 1.8V.

HD Audio Link Frequency

Use this feature to select the HD audio link frequency. The options are 6 MHz, 12 MHz, and **24 MHz**.

iDisplay Link Frequency

Use this feature to select the HD audio link frequency. The options are 48 MHz and **96 MHz**.

► Serial IO Configuration**Touch Panel**

Use this feature to select which touch screen controller to use. The options are **SPI Touch** or I2C Touch.

BT/UART Mux Select

Use this feature to select which signal for the M.2 module. The options are **UART Signal** or BT Signal.

I2C0 Controller

Use this feature to enable or disable the Serial I/O Controller. The options are **Disabled** and Enabled.

****If this feature is Enabled, then the Serial IO I2C0 Settings submenu is available for configuration:***

► Serial IO I2C0 Setting**I2C IO Voltage Select**

Use this feature to select the I2C IO voltage controller. the options are **3.3V** and 1.8V.

Connected device

Use this feature to indicate what type of device is connected to this serial prot controller. The options are **Disabled**, Synaptics Precision Touchpad, Synaptics Forcepad, and Custom device.

DeepSx Power Policies

Use this item to configure the Advanced Configuration and Power Interface (ACPI) settings for the system. Enable S3 to use Standby Mode (Suspend-to-RAM) and maintain power supply to the system RAM when the system is in the sleep mode. Enable S4 to use Hibernation mode (Suspend to Disk) so that all data stored in of the main memory can be saved in a non-volatile memory area such as in a hard drive and then power down the system. Enable S5 to power off the whole system except the power supply unit (PSU) and keep the power button "alive" so that the user can "wake up" the system by using an USB keyboard or mouse. The options are **Disabled** and Enabled in S4-S5.

Wake on LAN

Use this feature to enable or disable the integrated LAN to wake up the system. The options are Disabled and **Enabled**.

Wake on WLAN Enable

Use this feature to enable or disable the PCI Express wireless LAN to wake up the system. The options are **Disabled** and Enabled.

Port 61h Bit-4 Emulation

Select Enabled to enable the emulation of Port 61h bit-4 toggling in SMM (System Management Mode). The options are Disabled and **Enabled**.

High Precision Timer

Select Enabled to activate the High Performance Event Timer (HPET) that produces periodic interrupts at a much higher frequency than a Real-time Clock (RTC) does in synchronizing multimedia streams, providing smooth playback and reducing the dependency on other timestamp calculation devices, such as an x86 RDTSC Instruction embedded in the CPU. The High Performance Event Timer is used to replace the 8254 Programmable Interval Timer. The options are Disabled and **Enabled**.

4.5 Security

This menu allows the user to configure the following security settings for the system.

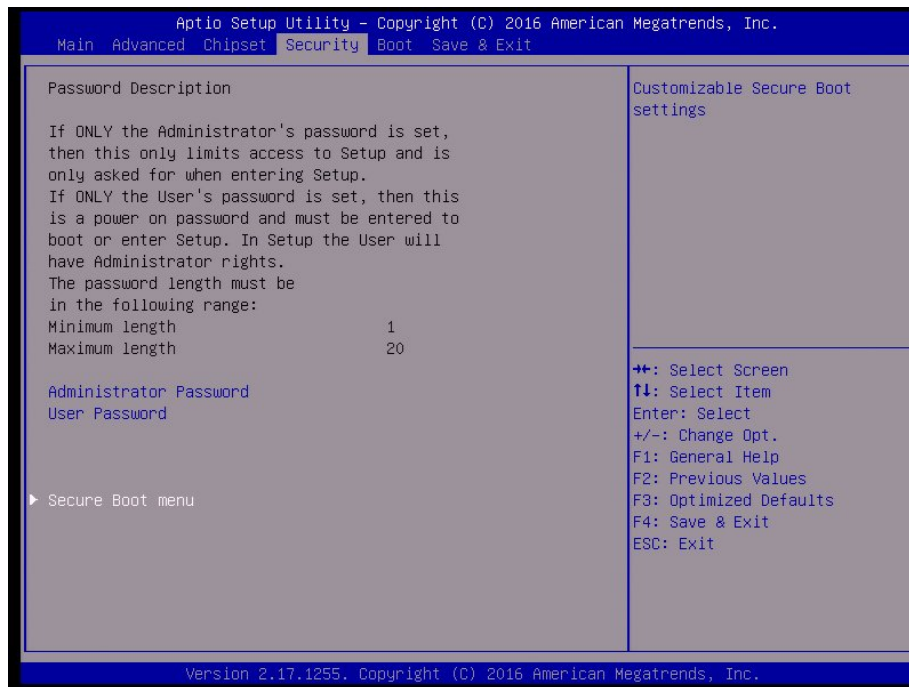

Administrator Password

Use this feature to set the administrator password which is required to enter the BIOS setup utility. The length of the password should be from 3 characters to 20 characters long.

User Password

Press Enter to create a new or change an existing User password.

► Secure Boot Menu

This section displays the contents of the following secure boot features:

- System Mode
- Secure Boot
- Vendor Keys

Secure Boot

Use this item to enable secure boot. The options are **Disabled** and **Enabled**.

Secure Boot Mode

Use this item to select the secure boot mode. The options are Standard and **Custom**.

▶ Key Management

This submenu allows the user to configure the following Key Management settings.

Provision Factory Default Keys

Select Enabled to install the default Secure-Boot keys set by the manufacturer. The options are **Disabled** and Enabled.

▶ Enroll All Factory Default Keys

Select Yes to install all default secure keys set by the manufacturer. The options are **Yes** and No.

Save All Secure Boot Variables

This feature allows the user to decide if all secure boot variables should be saved.

▶ Platform Key (PK)

This feature allows the user to configure the settings of the platform keys.

Set New Key

Select Yes to load the new platform keys (PK) from the manufacturer's defaults. Select No to load the platform keys from a file. The options are **Yes** and No.

▶ Key Exchange Keys

Set New Key

Select Yes to load the KEK from the manufacturer's defaults. Select No to load the KEK from a file. The options are Yes and No.

Append Key

Select Yes to add the KEK from the manufacturer's defaults list to the existing KEK. Select No to load the KEK from a file. The options are Yes and No.

▶ Authorized Signatures

Set New Key

Select Yes to load the database from the manufacturer's defaults. Select No to load the DB from a file. The options are Yes and No.

Append Key

Select Yes to add the database from the manufacturer's defaults to the existing DB. Select No to load the DB from a file. The options are Yes and No.

► Forbidden Signatures**Set New Key**

Select Yes to load the DBX from the manufacturer's defaults. Select No to load the DBX from a file. The options are Yes and No.

Append Key

Select Yes to add the DBX from the manufacturer's defaults to the existing DBX. Select No to load the DBX from a file. The options are Yes and No.

► Authorized TimeStamps**Set New Key**

Select Yes to load the DBT from the manufacturer's defaults. Select No to load the DBT from a file. The options are Yes and No.

Append Key

Select Yes to add the DBT from the manufacturer's defaults list to the existing DBT. Select No to load the DBT from a file. The options are Yes and No.

4.6 Boot

Use this feature to configure Boot Settings:

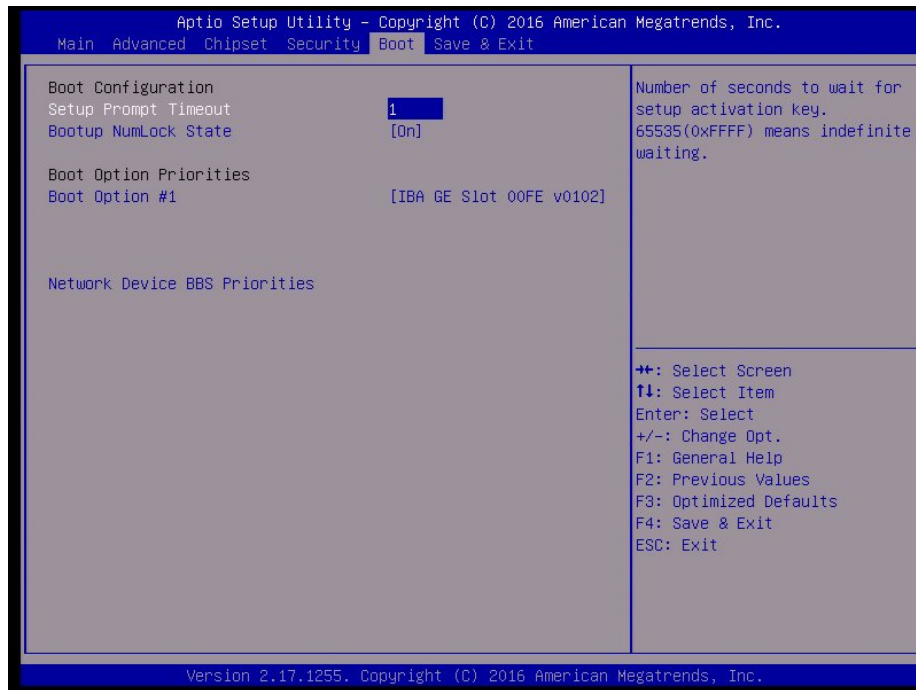

Setup Prompt Timeout

Use this item to indicate the length of time (the number of seconds) for the BIOS to wait before rebooting the system when the setup activation key is pressed. Enter the value of 65535 (0xFFFF) for the BIOS to wait indefinitely. The default setting is **1**.

Bootup NumLock State

Select On for the NumLock key to be activated during bootup. The options are **On** and Off.

Boot Option Priorities

This option prioritizes the order of bootable devices that the system to boot from. Press <Enter> on each entry from top to bottom to select devices.

- Boot Option #1

Network Device BBS Priorities

This feature allows the user to specify which Network devices are boot devices.

- Boot Order #1

4.7 Save & Exit

Select the Save & Exit tab from the BIOS setup screen to configure the settings below.



Save Options

Save Changes and Exit

When you have completed the system configuration changes, select this option to save all changes made and exit.

Discard Changes and Exit

Select this option and press <Enter> to discard all the changes and return to the AMI BIOS Utility Program.

Save Changes and Reset

When you have completed the system configuration changes, select this option to leave the BIOS setup utility and reboot the computer for the new system configuration parameters can take effect. Select Save Changes and Exit from the Exit menu and press <Enter>.

Discard Changes and Reset

Select this option to reset the setup without saving any changes.

Save Changes

After completing the system configuration changes, select this option to save the changes you have made. This will not reset (reboot) the system.

Discard Changes

Select this option and press <Enter> to discard all the changes and return to the AMI BIOS utility Program.

Restore Defaults

To set this feature, select Restore Defaults from the Exit menu and press <Enter>. These are factory settings designed for maximum system performance but not for maximum stability.

Save As User Defaults

To set this feature, select Save as User Defaults from the Exit menu and press <Enter>. This enables the user to save any changes to the BIOS setup for future use.

Restore User Defaults

To set this feature, select Restore User Defaults from the Exit menu and press <Enter>. Use this feature to retrieve user-defined settings that were saved previously.

Boot Override

This feature allows the user to override the Boot priorities sequence in the Boot menu and immediately boot the system with another device specified by the user. This is a one-time override.

Appendix A

BIOS Codes

A.1 BIOS Error POST (Beep) Codes

During the POST (Power-On Self-Test) routines, which are performed each time the system is powered on, errors may occur.

Non-fatal errors are those which, in most cases, allow the system to continue the boot-up process. The error messages normally appear on the screen.

Fatal errors are those which will not allow the system to continue the boot-up procedure. If a fatal error occurs, you should consult with your system manufacturer for possible repairs.

These fatal errors are usually communicated through a series of audible beeps. The table below lists some common errors and their corresponding beep codes encountered by users.

BIOS Beep (POST) Codes		
Beep Code	Error Message	Description
1 beep	Refresh	Circuits have been reset (Ready to power up)
5 short, 1 long	Memory error	No memory detected in system
5 long, 2 short	Display memory read/write error	Video adapter missing or with faulty memory
1 long continuous	System OH	System overheat condition

A.2 Additional BIOS POST Codes

The AMI BIOS supplies additional checkpoint codes, which are documented online at <http://www.supermicro.com/support/manuals/> ("AMI BIOS POST Codes User's Guide").

When BIOS performs the Power On Self Test, it writes checkpoint codes to I/O port 0080h. If the computer cannot complete the boot process, a diagnostic card can be attached to the computer to read I/O port 0080h (Supermicro p/n AOC-LPC80-20).

For information on AMI updates, please refer to <http://www.ami.com/products/>.

Appendix B

Software Installation

B.1 Installing Software Programs

The Supermicro FTP site contains drivers and utilities for your system at <ftp://ftp.supermicro.com>. Some of these must be installed, such as the chipset driver.

After accessing the FTP site, go into the CDR_Images directory and locate the ISO file for your motherboard. Download this file to create a CD/DVD of the drivers and utilities it contains. (You may also use a utility to extract the ISO file if preferred.)

After creating a CD/DVD with the ISO files, insert the disk into the CD/DVD drive on your system and the display shown in Figure B-1 should appear.

Another option is to go to the Supermicro website at <http://www.supermicro.com/products/>. Find the product page for your motherboard here, where you may download individual drivers and utilities to your hard drive or a USB flash drive and install from there.

 **Note:** To install the Windows OS, please refer to the instructions posted on our website at <http://www.supermicro.com/support/manuals/>.

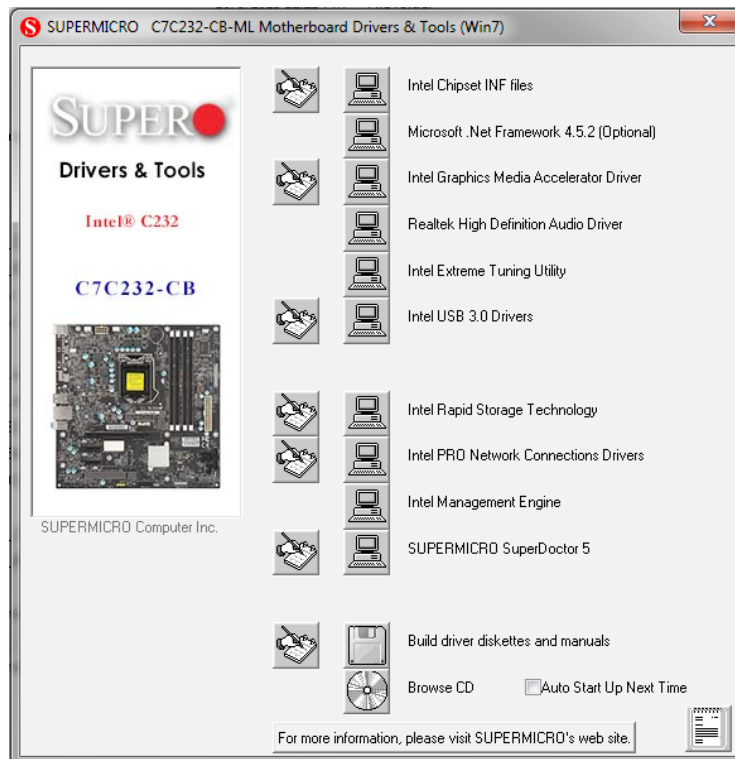

Figure B-1. Driver/Tool Installation Display Screen

Click the icons showing a hand writing on the paper to view the readme files for each item. Click a computer icon to the right of an item to install an item (from top to the bottom) one at a time. After installing each item, you must reboot the system before proceeding with the next item on the list. The bottom icon with a CD on it allows you to view the entire contents of the CD.

When making a storage driver diskette by booting into a driver CD, please set the SATA Configuration to "Compatible Mode" and configure SATA as IDE in the BIOS Setup. After making the driver diskette, be sure to change the SATA settings back to your original settings.

B.2 SuperDoctor® 5

The Supermicro SuperDoctor 5 is a hardware monitoring program that functions in a command-line or web-based interface in Windows and Linux operating systems. The program monitors system health information such as CPU temperature, system voltages, system power consumption, fan speed, and provides alerts via email or Simple Network Management Protocol (SNMP).

SuperDoctor 5 comes in local and remote management versions and can be used with Nagios to maximize your system monitoring needs. With SuperDoctor 5 Management Server (SSM Server), you can remotely control power on/off and reset chassis intrusion for multiple systems with SuperDoctor 5 or IPMI. SD5 Management Server monitors HTTP, FTP, and SMTP services to optimize the efficiency of your operation.



Note: The default Username and Password for SuperDoctor 5 is admin / admin.

Figure B-2. SuperDoctor 5 Interface Display Screen (Health Information)



Note: The SuperDoctor 5 program and user's manual can be downloaded from the Supermicro website at http://www.supermicro.com/products/info/sms_sd5.cfm.

Appendix C

Standardized Warning Statements

The following statements are industry standard warnings, provided to warn the user of situations which have the potential for bodily injury. Should you have questions or experience difficulty, contact Supermicro's Technical Support department for assistance. Only certified technicians should attempt to install or configure components.

Read this section in its entirety before installing or configuring components.

These warnings may also be found on our website at http://www.supermicro.com/about/policies/safety_information.cfm.

Battery Handling



Warning! There is the danger of explosion if the battery is replaced incorrectly. Replace the battery only with the same or equivalent type recommended by the manufacturer. Dispose of used batteries according to the manufacturer's instructions

電池の取り扱い

電池交換が正しく行われなかった場合、破裂の危険性があります。交換する電池はメーカーが推奨する型、または同等のものを使用下さい。使用済電池は製造元の指示に従って処分して下さい。

警告

電池更換不當會有爆炸危險。請只使用同類電池或製造商推薦的功能相當的電池更換原有電池。請按製造商的說明處理廢舊電池。

警告

電池更換不當會有爆炸危險。請使用製造商建議之相同或功能相當的電池更換原有電池。請按照製造商的說明指示處理廢棄舊電池。

Warnung

Bei Einsetzen einer falschen Batterie besteht Explosionsgefahr. Ersetzen Sie die Batterie nur durch den gleichen oder vom Hersteller empfohlenen Batterietyp. Entsorgen Sie die benutzten Batterien nach den Anweisungen des Herstellers.

Attention

Danger d'explosion si la pile n'est pas remplacée correctement. Ne la remplacer que par une pile de type semblable ou équivalent, recommandée par le fabricant. Jeter les piles usagées conformément aux instructions du fabricant.

¡Advertencia!

Existe peligro de explosión si la batería se reemplaza de manera incorrecta. Reemplazar la batería exclusivamente con el mismo tipo o el equivalente recomendado por el fabricante. Desechar las baterías gastadas según las instrucciones del fabricante.

אזהרה!

קיימת סכנת פיצוץ של הסוללה במידה והוחלפה בדרך לא תקינה. יש להחליף את הסוללה בסוג התואם מחברת יצרן מומלצת. סילוק הסוללות המשומשות יש לבצע לפי הוראות היצרן.

هناك خطر من انفجار في حالة اسبدال البطارية بطريقة غير صحيحة فعلي
اسبدال البطارية فقط بنفس النع أو ما يعادلها مما أوصت به الشركة المصنعة
جخلص من البطاريات المسحمة وفقا لعمليات الشركة الصانعة

경고!

배터리가 올바르게 교체되지 않으면 폭발의 위험이 있습니다. 기존 배터리와 동일하거나 제조사에서 권장하는 동등한 종류의 배터리로만 교체해야 합니다. 제조사의 안내에 따라 사용된 배터리를 처리하여 주십시오.

Waarschuwing

Er is ontploffingsgevaar indien de batterij verkeerd vervangen wordt. Vervang de batterij slechts met hetzelfde of een equivalent type die door de fabrikant aanbevolen wordt. Gebruikte batterijen dienen overeenkomstig fabrieksvoorschriften afgevoerd te worden.

Product Disposal



Warning! Ultimate disposal of this product should be handled according to all national laws and regulations.

製品の廃棄

この製品を廃棄処分する場合、国の関係する全ての法律・条例に従い処理する必要があります。

警告

本产品的废弃处理应根据所有国家的法律和规章进行。

警告

本產品的廢棄處理應根據所有國家的法律和規章進行。

Warnung

Die Entsorgung dieses Produkts sollte gemäß allen Bestimmungen und Gesetzen des Landes erfolgen.

¡Advertencia!

Al deshacerse por completo de este producto debe seguir todas las leyes y reglamentos nacionales.

Attention

La mise au rebut ou le recyclage de ce produit sont généralement soumis à des lois et/ou directives de respect de l'environnement. Renseignez-vous auprès de l'organisme compétent.

סילוק המוצר

אזהרה!

סילוק סופי של מוצר זה חייב להיות בהתאם להנחיות וחוקי המדינה.

عند التخلص النهائي من هذا المنتج ينبغي التعامل معه وفقا لجميع القوانين واللوائح الوطنية

경고!

이 제품은 해당 국가의 관련 법규 및 규정에 따라 폐기되어야 합니다.

Waarschuwing

De uiteindelijke verwijdering van dit product dient te geschieden in overeenstemming met alle nationale wetten en reglementen.

Appendix D

UEFI BIOS Recovery

Warning: Do not upgrade the BIOS unless your system has a BIOS-related issue. Flashing the wrong BIOS can cause irreparable damage to the system. In no event shall Supermicro be liable for direct, indirect, special, incidental, or consequential damages arising from a BIOS update. If you need to update the BIOS, do not shut down or reset the system while the BIOS is updating. Doing so may cause a boot failure.

D.1 Overview

The Unified Extensible Firmware Interface (UEFI) provides a software-based interface between the operating system and the platform firmware in the pre-boot environment. The UEFI specification supports an architecture-independent mechanism for add-on card initialization to allow the UEFI OS loader, which is stored in the add-on card, to boot the system. The UEFI offers clean, hands-off control to a computer system at bootup.

D.2 Recovering the UEFI BIOS Image

A UEFI BIOS flash chip consists of a recovery BIOS block and a main BIOS block (a main BIOS image). The boot block contains critical BIOS codes, including memory detection and recovery codes for the user to flash a new BIOS image if the original main BIOS image is corrupted. When the system power is on, the boot block codes execute first. Once it is completed, the main BIOS code will continue with system initialization and bootup.

 **Note:** Follow the BIOS recovery instructions below for BIOS recovery when the main BIOS boot crashes. However, if the BIOS boot block crashes, you will need to follow the procedures below for BIOS recovery.

D.3 Recovering the BIOS Block with a USB Device

This feature allows the user to recover a BIOS image using a USB-attached device without the need for additional utilities. A USB flash device such as a USB flash drive or a USB CD/DVD device can be used for this purpose. A USB hard disk drive cannot be used for BIOS recovery at this time.

The file system supported by UEFI is FAT (including FAT12, FAT16, and FAT32) installed on a bootable or non-bootable USB-attached device. Note that the BIOS might need several minutes to locate the SUPER.ROM file if the media size becomes too large because it contains too many folders and files.

To perform UEFI BIOS recovery using a USB-attached device, follow the instructions below.

1. Using a different system, copy the "Super.ROM" binary image file into the disc Root "" Directory of a USB device or a writeable CD/DVD.

 **Note:** If you cannot locate the "Super.ROM" file in your driver disk, visit our website at www.supermicro.com to download the BIOS image into a USB flash device and rename it "Super.ROM".

2. Insert the USB device that contains the new BIOS image ("Super.ROM") into your USB drive and power on the system.
3. While powering on the system, please keep pressing <Ctrl> and <Home> simultaneously on your keyboard *until the following screen (or a screen similar to the one below) displays.*

Warning: Please **stop** pressing the <Ctrl> and <Home> keys immediately when you see the screen (or a similar screen) below; otherwise, it will trigger a system reboot.



 **Note:** On the other hand, if the following screen displays, please load the "Super.ROM" file to the root folder and connect this folder to the system. (You can do so by inserting a USB device that contains the new "Super.ROM" image to your machine for BIOS recovery.)



4. After locating the new BIOS binary image, the system will enter the BIOS Recovery menu as shown below.

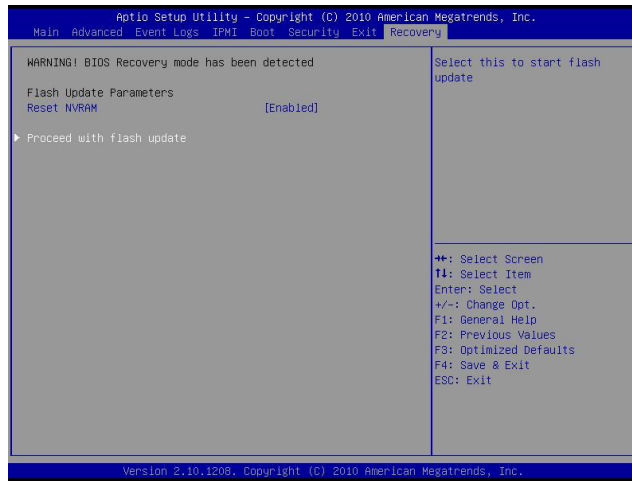

 **Note:** At this point, you may decide if you want to start the BIOS recovery. If you decide to proceed with BIOS recovery, follow the procedures below.

5. When the screen as shown above displays, use the arrow keys to select the item "Proceed with flash update" and press the <Enter> key. You will see the BIOS recovery progress as shown in the screen below.

 **Note:** Do not interrupt the BIOS flashing process until it has completed.

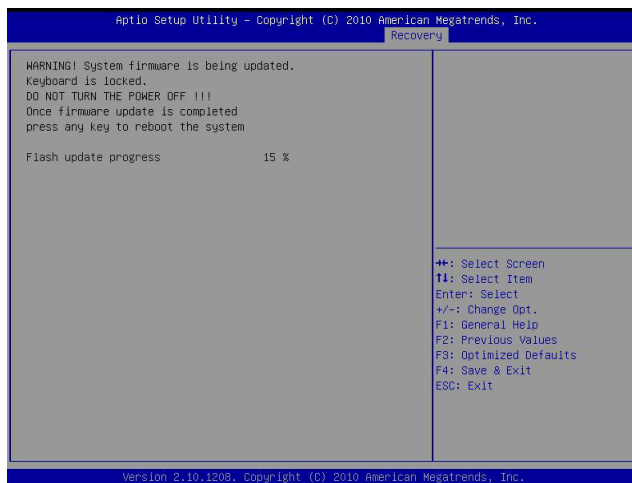

6. After the BIOS recovery process has completed, press any key to reboot the system.

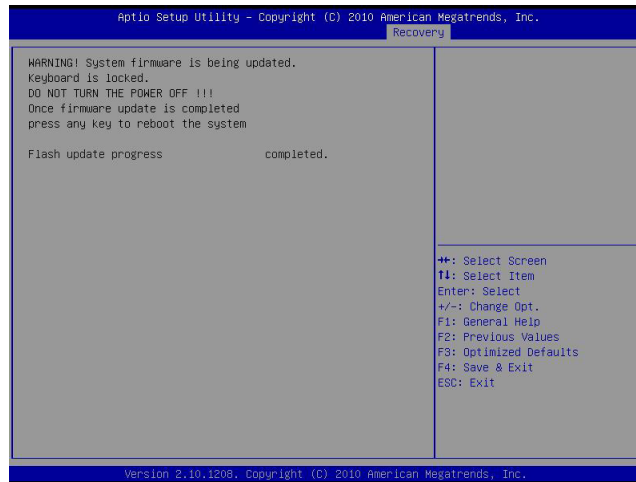

7. Using a different system, extract the BIOS package into a bootable USB flash drive.
8. When a DOS prompt appears, enter FLASH.BAT BIOSname.### at the prompt.



Note: *Do not interrupt this process* until the BIOS flashing is complete.

9. After seeing the message that BIOS update has completed, unplug the AC power cable from the power supply, clear CMOS, then plug the AC power cable in the power supply again to power on the system.
10. Press continuously to enter the BIOS Setup utility.
11. Press <F3> to load the default settings.
12. After loading the default settings, press <F4> to save the settings and exit the BIOS Setup utility.